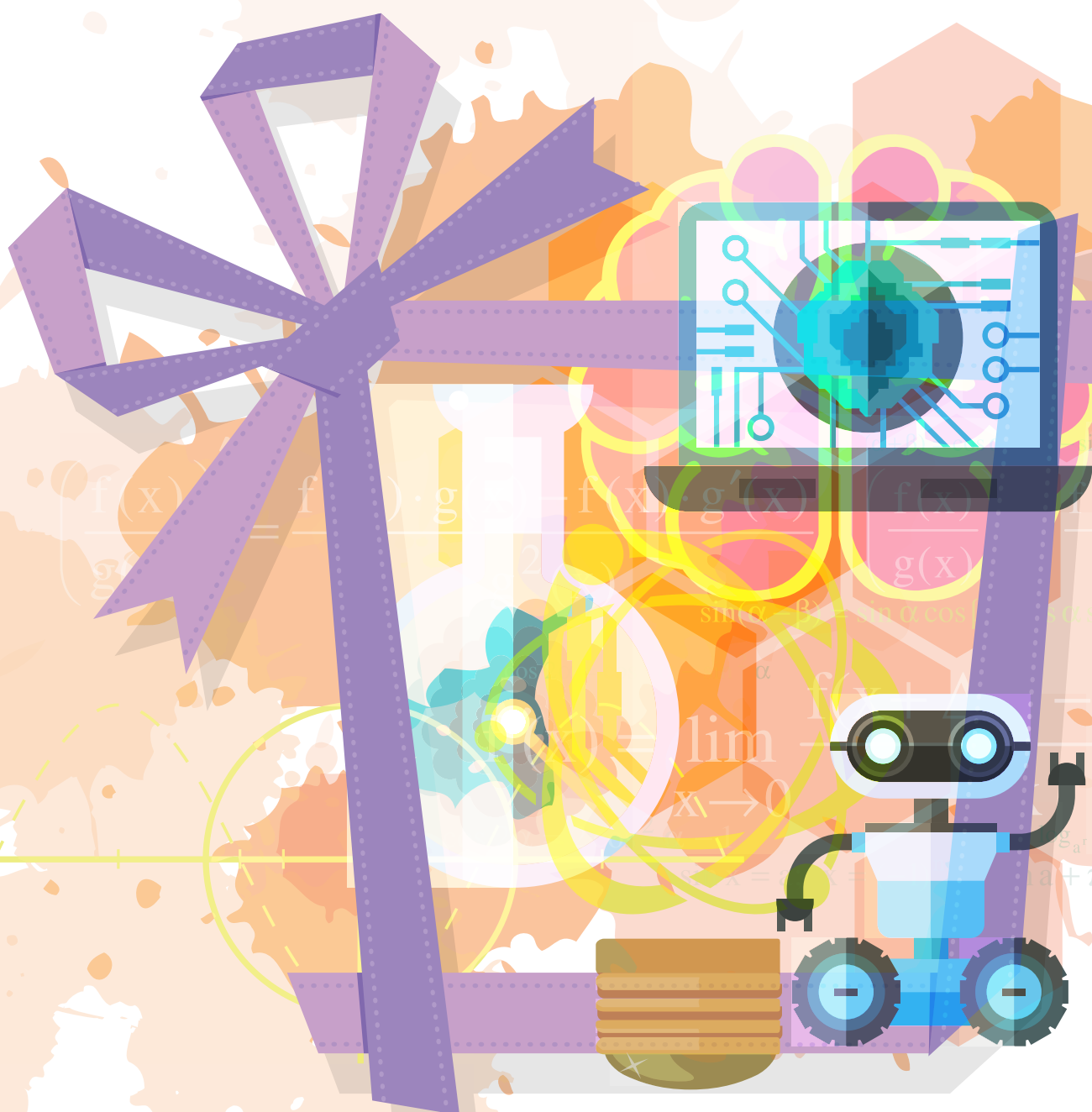


# 校本資優教育：學與教資源套

## School-based Gifted Education: Learning & Teaching Resource Package



捐助機構 **Funded by**





賽馬會「知優致優」計劃  
Jockey Club "Giftedness Into Flourishing Talents" Project

Secondary

Mathematics  
&  
Integrated Science

# 校本資優教育：學與教資源套

## School-based Gifted Education: Learning & Teaching Resource Package



捐助機構 **Funded by**

CENTRE FOR  
UNIVERSITY & SCHOOL  
PARTNERSHIP  
大學與學校夥伴關係中心  
香港中文大學教育學院 • FACULTY OF EDUCATION, HKU



香港賽馬會慈善信託基金  
The Hong Kong Jockey Club Charities Trust  
同心 同步 同進 RIDING HIGH TOGETHER

常言道：「十年樹木，百年樹人。」在現今瞬息萬變、科技日新月異的社會，教育更要與時俱進，為不同背景和能力的人士，提供平等的學習機會，謀求多元出路。資優學生可能會被認為較一般學生有優勢，但其實他們也有特殊的學習需要。

為推動多元教育，讓每名學生盡展才華，香港賽馬會慈善信託基金於2016年審批撥款4,850萬港元，捐助香港中文大學推行以實證為本的**賽馬會「知優致優」計劃**，三年來致力促進校本資優教育三層架構推行模式的第一和第二層的發展，按照學生的不同需要設計全班式增潤課程，制定校本拔尖系統，讓表現出眾的資優學生接受抽離式栽培，並向二十間中、小學提供到校支援，建立學生人才庫，訓練接近2,600名老師，藉着工作坊、分享會和海外交流，擴闊教師視野，提升專業能力。

誠然，家長亦扮演舉足輕重的角色。計劃舉辦多項家長教育活動，支援逾1,200名父母了解及學習如何協助子女探索興趣，發揮所長。通過多管齊下的全方位策略，超過15,000名資優與非資優學生在課堂內外，均能順應各自天賦、獨有特質和學習能力而得到培育，從而充分發揮潛能，達致全人發展，做到因材施教、知優致優的效果。

除了**賽馬會「知優致優」計劃**，我們亦捐助**賽馬會「知情達意育優才」計劃**，透過情意教育協助資優生克服情緒和社交適應問題，人盡其才。此外，馬會於2019年初開展**賽馬會「校本多元」計劃**，旨在建構多元友善學習環境，使不同能力的學生能有效地學習及融合，讓老師能發揮及保持對教學的熱誠，達致「有意義的學與教」。

馬會位列全球十大慈善捐助機構之一，推動教育發展不遺餘力。近年更訂立四大優先捐助的教育項目範疇，包括：培養學生具具備二十一世紀的學習能力、闡釋多元學習需要、推廣教育創新及科技教育，以及幼兒教育。我們亦繼續重點推動青年、長者、體育，以及藝術、文化和保育等慈善策略範疇的工作，回應社會不同需要，讓更多市民受惠。

**賽馬會「知優致優」計劃**順利圓滿完成，實有賴香港中文大學和跨院校團隊所付出的心血和努力，以及主力與網絡學校、老師和家長們的積極支持，我謹此致以衷心的謝意，希望這份資源套有助推動本地資優教育的長遠發展，孕育未來社會棟樑，造福香港。

香港賽馬會慈善及社區事務執行總監  
張亮先生



As the Chinese proverb says, “It takes 10 years to grow trees but 100 years to develop people.” In light of today’s ever-changing environment with rapid technological advancements, it is important that education keeps abreast with the times and provides equal learning opportunities for those with different backgrounds and abilities to explore multiple pathways. Although gifted students may be perceived to have an advantage, they also have special education needs.

To cater to diverse educational needs and fully unleash the potential of students, **The Hong Kong Jockey Club Charities Trust** approved a donation of HK\$48.5 million in 2016 for The Chinese University of Hong Kong to launch the evidence-based **Jockey Club “Giftedness Into Flourishing Talents” Project**. For the past three years, the initiative has strengthened support at Levels 1 and 2 of the three-tier School-based Gifted Education framework by offering enrichment programmes and differentiated curriculums for all students, developing a school-based talent research model, and delivering pull-out programmes for more abled and talented students. A total of 20 primary and secondary schools have been provided with on-site support to establish a student portfolio, while nearly 2,600 educators have been trained through workshops, sharing sessions and overseas trips to widen their horizons and enhance their professional capacity.

Recognising that parents play a crucial role, the project has implemented an array of parent-education activities to help over 1,200 parents understand and learn how to develop their children’s interest and potential. Thanks to a holistic, multi-pronged approach, more than 15,000 gifted and non-gifted students have been nurtured inside and outside the classroom based on their individual talents, characteristics and learning abilities, so that their potential can be fully realised alongside whole-person development. This is consonant with the principle of “enabling students to thrive by teaching in line with their abilities”.

In addition to this project, the Trust has supported the **Jockey Club “Gifted in Bloom – Harmony in Heart & Mind” Programme** to help gifted learners tackle issues regarding their emotions and social skills via affective education, so as to maximise their talents. In early 2019, we supported the **Jockey Club “Diversity at Schools” Project**, which aims to create a meaningful learning experience through the cultivation of a diverse and learning-friendly environment for students of different abilities. The project also aims to enhance teaching practice.

As one of the world’s top ten charity donors, the Club spares no efforts in promoting development of local education. In recent years, we have placed top priority on four major educational areas. They include projects to equip our younger generation with 21st century skills; students with diverse learning needs; promoting innovation in education and technology education, as well as early childhood education. As always, the Club is dedicated to addressing different social needs and benefiting as many citizens as possible with Youth, the Elderly, Sports, and Arts, Culture and Heritage as its strategic areas of focus.

On this encouraging note, I would like to extend my sincere thanks to The Chinese University of Hong Kong and the inter-institutional team for their steadfast commitment, together with all participating key and network schools, teachers and parents, for their enthusiastic support for the **Jockey Club “Giftedness Into Flourishing Talents” Project**. I hope this education kit supports the long-term development of gifted education in Hong Kong to help nurture our future leaders and innovators for a better Hong Kong.

Leong Cheung

Executive Director, Charities and Community, The Hong Kong Jockey Club

在升學競爭激烈的香港，學生忙於應付測考，教師忙於追趕課堂進度，已成為教育界的常態。但作為教育工作者，回歸初心，成績絕不是唯一的追求。我們相信每一個學生都是獨特的，更期望學校能成為他們潛能盡展的地方。

正因如此，校本資優教育顯得更為重要，按照學生的特性與需要，設計多元化的教學活動，不但使他們吸收知識，同時享受學習、發揮所長。過去三年，賽馬會「知優致優」計劃的團隊走進了二十所計劃學校的校園，與前線教師緊密溝通、合作，目的正是按每所學校、每個班級的特質，「度身訂造」最合適的教學方案。

實有賴教育界同工的努力，構思並實行一個個別開生面的課程，資優教育才得以在校內紮根。從課堂觀察和教師回饋，不難發現學生較以往投入學習，展現出不同才能，教師的滿足感也不言而喻。

然而，這僅僅是開始，要使本地更多師生受惠，資優教育的理念需要進一步被推廣，這也是《校本資優教育：學與教資源套》面世的主要原因。資源套內匯集了計劃團隊與各學校的協作成果，所刊載的三十二個教學單元，全部以學與教理論為根據，並詳述學校校情及學生特點，輔以教案及教學資源。除了介紹課程及提供資源外，每個單元亦有討論的部分，記錄課堂實踐的情況，讓使用者了解實際運作上可能有的困難，以及可如何改善。

我們期望一方面，計劃學校能以這些課程為基礎，繼續推行校本資優教育，甚至推而廣之，在更多班級、科目上應用；另一方面，其他學校能靈活運用教材，作出適當的調整，以突破固有教學框架，增強學與教的成效。

感謝香港賽馬會慈善信託基金的慷慨捐助，使賽馬會「知優致優」計劃得以順利開展，並出版《校本資優教育：學與教資源套》。資源套不單是實用的教材，也是協作三年的寶貴成果，所記載之成功經驗正是實證，證明校本資優教育的意義與可行。期盼資優教育的元素，能廣泛地出現本地的課堂上，讓師生有不一樣的學習體驗。

賽馬會「知優致優」計劃 召集人兼聯席總研究顧問  
張志強教授

In Hong Kong where intense competition takes place, students are exhausted with tests and teachers are busy catching up with the curriculum progress. Despite this norm in our education sector, when an educator remembers his or her very beginning mind, academic achievement is by no means the only pursuit. We believe students are all unique, and schools should be a place to unleash their potential.

This explains the importance of the School-based Gifted Education. Learning activities are designed according to the characteristics and needs of students, enabling them to acquire knowledge, enjoy the learning process and make good use of talents at the same time. Over the past three years, the **Jockey Club “Giftedness Into Flourishing Talents”** Project has entered the campuses of 20 Project Schools and worked closely with frontline teachers. The collaborative effort aimed at tailor-making teaching programmes, based on the uniqueness of every school and every class of students.

The effort of the Project Schools in creating and putting the innovative teaching programmes into practice is highly appreciated. From the class observation and feedback from teachers, as gifted education starts to take root in the schools, students became remarkably engaged in learning and showcased different talents and potentials. Teachers in turn gained a sense of satisfaction.

It is just the beginning. In order to reach more beneficiaries, particularly local teachers and students, School-based Gifted Education needs to be further promoted. This is also the main reason for the publication of *“School-based Gifted Education: Learning and Teaching Resource Package”*.

For each of the 32 teaching units published, theoretical background is provided with the introduction of the school and student characteristics in each participating school, supplemented by lesson plans and learning resources. The discussion part gives a reflection on the effectiveness as well as difficulties in practical implementation. Users of the resource package can thus have a better planning to overcome the possible difficulties and further improve their lessons.

We hope that the Project Schools, with the establishment of a good foundation of School-based Gifted Education, do not only continue but also extend it to other grades and subjects. Other schools can flexibly adapt and use the teaching materials, break the existing teaching framework, so as to enhance students’ learning effectiveness.

We must express our deepest gratitude to **The Hong Kong Jockey Club Charities Trust** for the generous funding support, under which the **Jockey Club “Giftedness Into Flourishing Talents”** Project could be successfully completed and *“School-based Gifted Education: Learning and Teaching Resource Package”* is published. The resource package is both useful and valuable as an outcome of the three-year collaboration, proving the significance and feasibility of School-based Gifted Education. We eagerly anticipate that the elements of gifted education will widely appear in local classrooms, bringing new and rewarding learning and teaching experiences.

Alan C. K. Cheung, PhD  
Convener & Co-Chief Principal Investigator,  
Jockey Club “Giftedness Into Flourishing Talents”

# 目錄 Contents

2 序 / 張亮先生

*Preface / Leong Cheung*

5 序 / 張志強教授

*Preface / Alan C. K. Cheung, PhD*

9 引言

*Introduction*

數學科 第一層：校本全班式教學

*Mathematics Level 1: School-based Whole-class Teaching*

36 S1 Percentage - Discount

49 S2 Proofs of Pythagoras' Theorem

92 S2 Golden Ratio and Fibonacci Sequence

124 中三級 物有相似

數學科 第二層：校本抽離式計劃

*Mathematics Level 2: School-based Pull-out Programme*

144 S2 or S3 Extension of Pythagoras' Theorem

199 S2 Isoperimetric Problem

綜合科學科 第一層：校本全班式教學

*Integrated Science Level 1: School-based Whole-class Teaching*

248 S2 Making an Electric Circuit Game

綜合科學科 第二層：校本抽離式計劃

*Integrated Science Level 2: School-based Pull-out Programme*

262 S2 Wearable Electronic Clothes

274 總結

*Conclusion*

281 參考文獻

*References*

286 鳴謝

*Acknowledgements*

# 引言

是次出版的《校本資優教育：學與教資源套》是賽馬會「知優致優」計劃與二十間本地計劃學校（十五間小學及五間中學）在2017/2018和2018/2019年度，共同合作的專業成果。計劃由香港中文大學教育學院「大學與學校夥伴協作中心」主辦，並獲得香港賽馬會慈善信託基金的資助。此計劃由香港中文大學、香港理工大學、香港城市大學和香港教育大學的學者組成跨院校研究團隊，推動本地發展校本資優教育。

為了加深讀者對推行資優教育和與計劃學校的校本專業協作的認識，本章節會有四個主要目的。首先會重點探討現今社會對資優的觀點，剖析資優相關的概念及理論模式。然後會闡述資優教育的策略，以培育高能力和資優學生。接著會討論香港的資優教育發展，包括資優教育的要素，以及三層架構推行模式。最後會介紹此《校本資優教育：學與教資源套》的專業協作背景、目的和主要組成部分。

本團隊希望透過出版此資源套，為本地中小學提供有效的平台傳播和分享學與教的資源。更重要的是希望為對資優教育有興趣的教育同工、教師、課程領導及學校行政人員，提供豐富的教學實例及資源，包括校本增潤課程和才能發展（L1），以及為高能力和資優學童而設的校本抽離式計劃（L2）。

## 資優的現代觀點

### 何謂資優？

資優一直以智力或用心理測量學方法測量的智商水平作定義，而社會上普遍以西方國家採用的智商測試作參考指標來分辨資優生(Chan, 2018)。可是，資優和智商的概念隨著時代變遷而出現了不少重大的變化。智商水平不再是「辨別資優的合適工具」(Chan, 2018, p.73)，反而採用多元準則來廣泛定義資優更為適切。

U.S. Marland's Report (1972)提出資優的本質涵蓋多種方面及角度，《教育統籌委員會第四號報告書》(1990)就此指出資優的定義，並提出解決香港資優兒童教育需要的方案，界定資優兒童是在以下一方面或多方面有卓越成就或潛能的兒童。

- (a) 智力經測定屬高水平；
- (b) 對某一學科有特強的資質；
- (c) 有獨創性思考－能夠提出很多創新而精闢詳盡的意見；
- (d) 在繪畫、戲劇、舞蹈、音樂等視覺及表演藝術方面極有天份；
- (e) 有領導同輩的天賦才能－在推動他人完成共同目標方面有極高的能力；



(f) 心理活動能力—有卓越的表現，或在競技、機械技能或體能的協調均有特出的天份 (Education Commission, 1990, p.47)

### 資優的理論模式

亞洲地區對資優的文化認知與兩個主要的理論模式息息相關，分別是Renzulli (1978) 的三環概念(圖1)，以及Gardner (1983) 的多元智能理論(圖2)。

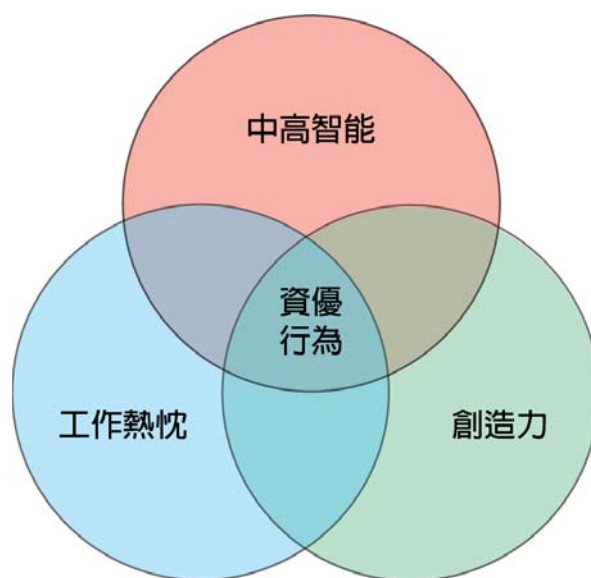
資優三環概念認為資優行為是綜合三類基本人類特性，即中高智能、高度的工作熱忱(動力)、以及高度的創造力。

中高智能是其中一項主要部分，一般智能的特性應用於大多甚至全部的範疇，「能夠處理資訊、綜合過往經驗以適應新情況、以及有能力進行高度抽象的思考」(Renzulli, 2010, p.259)。因此，語言和數字推理、空間關係、記憶及語文流暢也屬一般智能。另一方面，特殊智能是「在特定知識領域或人類表現領域，掌握並擅用知識和技巧，並且應用一或多種一般智能的能力」(Renzulli, 2010, p.260)。

工作熱忱是第二項特質，意指對特定問題、特定表現領域展現高度興趣及熱愛。工作熱忱與一個人的毅力、耐力、努力、專注力、自信心等有關，相信自己可以擔大任，並將自己的興趣付諸行動。總括而言，工作熱忱可以由內在或外在推動的(Renzulli, 2010)。

創造力是分辨資優的第三項特質。根據修訂版的Taxonomy of Anderson et al. (2001)，創造力在認知過程中扮演著重要角色。理論將認知能力分為六個層次，分別是記下、理解、應用、分析、評鑑及創造；當中創造力是位於認知層次的頂端。

總括而言，擁有上述特性的資優學童「能夠在人類表現領域中，發展及應用資優的特質在有任何潛在價值的地方上」(Chan, 2018, p.74)。值得一提的是，把重點放在一個人的能力和工作熱忱，與儒家思想中的「付出和努力」概念不謀而合。儒家學說特別着重一個人的能力，在華人社會中尤其明顯。在創造力方面，大眾普遍都會認為儒家提倡的集體主義價值觀如遵守和服從性，並不太能啟發及培養創造力。因此，要栽培資優孩子，學者均指出推動創造力是很多亞洲地區的首要任務，特別是在內地、香港、新加坡及南韓等地區 (Chan, 2018; Hui & Lau, 2010)。



圖一：三環概念 (Three ring conception of giftedness; Renzulli, 1978, p.83)

有見大多數有關資優的研究都與智能關連，有些學者家針對智能而研發一些新的理論模式。對 Gardner (1983) 而言，智能並不是個單一的概念，而是牽涉多個層面的概念。在初期的理論，他制定了智能的七個範疇，包括語文、數理邏輯、空間、肢體動覺、音樂、人際、以及內省智能。其後，他增設了第八種智能 — 靈性、道德及自然智能 (Gardner, 1999)。這個嶄新概念對腦部智能方面加以重視，改變了對資優的固有概念。



圖二：多元智能理論

總結來說，多元智能理論與儒家在教育方面的理念是相同的，兩者都認同需要均衡發展學生的德、智、體、群、美 (Chan, 2008)。同樣地，Sternberg和Reis (2004) 主張資優涉及的範疇遠超智能這一方面，並且是由認知和非認知的部分共同組成。Sternberg和O'Hara (1999) 提出智能只是六種推動創意思考和行為的力量之一。從創意生產力的角度來看，資優行為融合了智力、知識、思考方式、性格、動力和周遭環境等影響因素。此外，Renzulli (2010) 亦認同資優概念的延伸並不只是單純採用學術上的定義，他重申「多元才能」和「多元範疇」的價值對認清高潛能和資優學童的特質是相當重要的。

### 適異性教學策略

資優和高能力孩子展現的獨特學習方式，引起不同模式的教育需要。資優學生一般需要豐富的「學習經驗，而且這些經驗是由個別學科的重要概念和理論組成，而非單純由事實組成」(Tomlinson, 2019, p.1)。相比起非資優學生及同齡朋輩，資優學生傾向更快及更持續地以複雜和抽象的方式掌握到深奧的資資訊 (Brody & Benbow, 1987; Little, 2018)。

基於資優學生的獨特特質和需要，採用適異性教學符合儒家思想中的「因材施教」理念。因此，適異性教學讓教師可以因應學生的個人能力和需要而教授不同的知識。

### 適異性

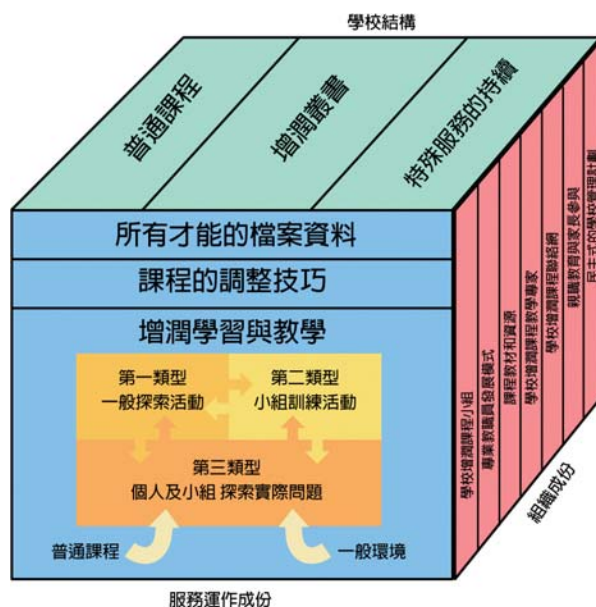
適異性是「將教育期望配合個別學生不同學習需要的過程」(Matthews & Foster, 2009, p.112)。這種策略經已證實對資優學生見效，尤其在異質分組的課堂裏。在課程層面可以作出不同的調適，如刪除不必要或重覆的內容、重整或深化內容、以及將學習單元延伸至其他科目或學科。在課堂層面，教師可以就學生的長處、興趣、或短處

彈性地分組，從而擴展和加深他們的學習體驗 (Wan, 2016)。

為資優生或高能力者提供適異經歷，對他們展現異常的能力和不同層面的才能十分重要。透過加速、濃縮課程及提升學習內容的深度，可以適切地滿足他們的教育需要，而且增潤的學習經歷更可協助他們提升聚合思維和想像，追求更遠的目標和獨立的能力 (Feldhusen, 1982; Griggs & Dunn, 1984; Tomlinson, 1994; VanTassel-Baska & Stambaugh, 2005)。下文將會討論適異性課程、教學方式以及相應的評估模式。

### 適異課程

在一般的課程架構中，校本增潤模式 (Schoolwide Enrichment Model, SEM, Renzulli, 2003; Renzulli & Reis, 1994, 1997; Renzulli & Renzulli, 2010) (圖3) 提出在課本內容、學習過程及成果中作出改動，從而照顧個別學生的需要。特別是教師應用的課程修改技巧應能做到 (a) 調整必修課程的難易度，讓所有學生都感挑戰性；(b) 消除所有學生的乏味感、提高挑戰性和參與度；以及 (c) 將不同的增潤單元融入常規課程體驗 (Renzulli & Reis, 2014, p.48)。其他研究者也建議以學生的特質作為衡量條件，來決定該課程應如何調適和作出適異 (Feldhusen, Hansen, & Kennedy, 1989; Maker & Nielson, 1996)。



圖三：校本增潤模式 (Schoolwide enrichment model, Renzulli, 2003, p.6)

很多人都認為對資優學生有效的教學方式，是將一般課程的難度、獨立性和能力要求提升。資優生大多比同齡的朋輩，在課堂學習時較喜歡接受更高難度的挑戰。VanTassel-Baska (1986) 提出，深化內容的重要性在於可以早一步刺激資優孩子，讓他們有更多的機會接觸新的學習模式和挑戰。因此，要挑戰資優和高才能的孩子，建議教師將學習內容、過程及成果，修訂得「較適合同齡學生的內容更複雜、更抽象、更開放和更能從多角度思考」 (Tomlinson, 2019)。

除了有能力消化更艱深的學習內容外，資優生對更具挑戰性的學習經歷也呈現出強烈傾向。在課堂層面，可利用教學速度、深度和機會為資優生提供挑戰性，以引導他們發展高層次思維，以及為自身興趣追求進階的難度 (Kanevsky & Keighley, 2003; Little, 2018)。

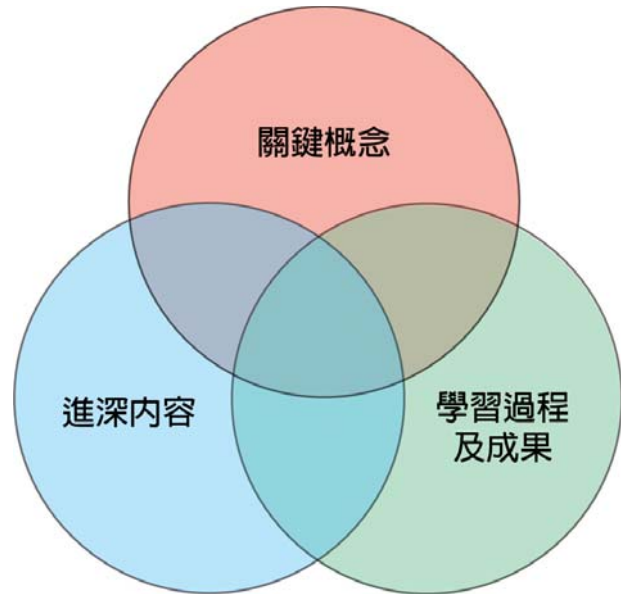
下文將會探討主要的教學實踐及教學策略，通過認清智能的特質和照顧資優生的學習需要，達致推動有效學習的目標。

### 濃縮課程

校本增潤模式其中一個最常用的適異性策略就是濃縮課程，對整合學習內容、過程、成果、課堂管理，以及教師照顧個別學生與小組差異而言，是不可或缺的部分。更重要的是，濃縮課程有助改善教學流程，以及為高潛能和高能力的學生提供更多富挑戰性的學習機會。當進展性評估鑑定出資優生早已掌握教學內容和技巧時，教學便可略過部份內容，並轉移至其他進階內容。由此可見，濃縮課程能有助實施其他的資優教學策略 (Reis & Purcell, 1993; Rogers, 2007)。

### 適異性教學

適異性教學是校本增潤模式的另一項特點，提倡在課堂上實施不同的教學策略。適異性教學是辨識課堂上不同類型的學生，以配合學生個人需要的一項嘗試 (Tomlinson, 2000)。她認為「優良的資優教學方式，是能夠以適切的教學步伐回應學生的個人需要」(Tomlinson, 2019, p.1)。資優和高能力的孩子學習速度較快。一方面他們希望課程可以濃縮而且教學步伐能較同儕快速，另一方面也期望加快教學步伐可以讓他們加深或拓闊認知，滿足對學習更大的渴求。



圖四：綜合課程模式

VanTassel-Baska (1986) 的綜合課程模

式 (Integrated Curriculum Model, ICM) (圖4) 為回應資優生的課程需要勾劃了一個框架，提到六種主要的適異性特質，分別是抽象性、深度、複雜性、創造力、加速以及挑戰性 (VanTassel-Baska, 2003)。

加速和挑戰性的主要目的是提升內容難度。透過加速，「教師預先評估學生對學習特定技巧的準備度，從而考慮濃縮新教材至更艱深的程度」。加速課程作為有效的策略，「涵蓋不同針對資優生而設的策略」(Little, 2018, p.374)。加速教學步伐和內容之所以變得可能，是透過將學生調至其他年級、提早教授進階內容，以及調整課堂內容以加快學生學習 (Assouline, Colangelo, & VanTassel-Baska, 2015)。

挑戰性牽涉使用複雜的內容和進階的資源，刺激學生探索更多 (VanTassel-Baska & Chandler, 2013)。深度、複雜性以及創造力是「過程-成果」向度的主要特點，這些策



略有助辨識資優學生特徵和程度，即他們保持專注在感興趣事物上的能力。有關深度的研究需要對該學生有一定的認識，以及在多個角度深入發掘他們的能力。同樣地，複雜性要求該學生在研究某個主題時，擁有多種高層次思維技巧和認識不同的變化因素。創造力則通過進階學習中的創意生產力，辨別資優學生的程度。

適異性教學的另一特點是抽象性，這個特點與綜合課程模式的概念 / 議題 / 主題向度緊密關連。在課程中加入抽象性，資優學生更有動力由實例延伸至概念性的思維技巧，繼而自行學會概括的技巧。

總結而言，綜合課程模式為資優生的學與教，在規劃課程和教學策略提供了符合本地社會情境的藍圖。綜合課程模式對第一層的資優教育課程（三層架構推行模式）尤其適用，因為可以在本地學校的正規課堂上推行全班式適異性教學。

### 分組

過往有研究發現以分組策略支援資優學生能起到作用，尤其在正規課堂裏實踐適異性教學時，靈活分組有助資優學生獲得成就感和寶貴的成果 (Rogers, 2007, Tomlinson, 2005)。在分組的教學策略中，學生會以他們不同的學術能力、學習方式及興趣分組，接受合適而具挑戰性的教學。Tomlinson (2005) 認為靈活分組會因應學生的特質、學習潛能和學習方式，幫助學生體驗多元的學習經歷。

總括而言，校本增潤模式作為資優教育中其中一個最常用和建基於實證的課程模式，啟發教育工作者去檢視每個學生的長處、興趣、學習方式、以及屬意的表達模式，並加以利用，為優越和高度積極的學生創造富挑戰性的學習機會 (Renzulli & Reis, 2014)。校本增潤模式旨在採用全校參與模式，培育所有學生的學習潛能，並堅信「一人得道，雞犬升天」，鼓勵他們盡情發揮自己的能力 (Renzulli & Reis, 2014)。

由此可見，要提升資優生的潛能和滿足他們的學習需要，學校應該為他們提供比一般教學課程更廣闊的多元化教育機會、資源和鼓勵。

### 適異性評估

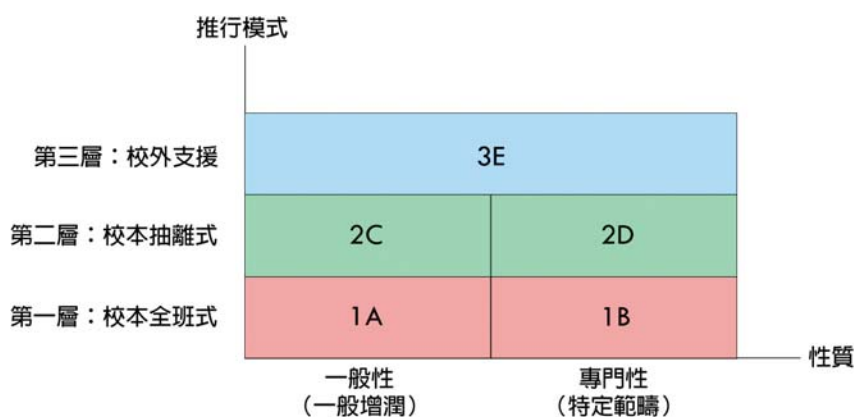
值得一提的是，綜合課程模式建議適異課程應輔以診斷式評估，除了因應資優學童的需要而修訂課程，定期的進展性評估可以確保資優學生所需的能力得以提升 (VanTassel-Baska, 2018)。一般而言會建議兩種評估模式，分別是表現為本評估及學習歷程檔案。

首先，表現為本評估要求學生展現高層次思維技巧、解難能力、創造力以及清晰表達指定的題目。第二，學習歷程檔案要求學生挑選及展示他們的代表作品，更重要的是，學習歷程檔案通常都會展示給家長及社會大眾，亦可以讓資優學生在學習過程中有更深入的了解和體驗 (VanTassel-Baska, 2008)。

## 香港的資優教育

### 三層架構推行模式

在香港層面，教育統籌委員會的第四號報告書(1990)提到，教育的願景是要滿足所有學生的學習需要。資優教育的主要目標是培育和發掘不同的潛能，以及透過資優教育培養每個學生展現卓越的能力。因此，所有本地學校應該致力為高能力和資優學生提供適切的學習機會，而校本資優培育計劃和支援則是讓資優生受惠的最佳方法(教育局，2019)。



圖五：三層架構推行模式 (The three-tiered implementation model; Education Department, 2000, p.6)

為了滿足資優學生獨特的特質和學習需要，自2000年起，三層架構推行模式(圖5)被採用在推行資優教育上。第一層是校本全班式教學，利用正規課堂的教學法，以及在正規課堂為所有學生而設的增潤課程，滲入資優教育的三大元素(高層次思維技巧、創造力和個人及社交能力)，激發學生的創造力、批判性思考能力、解難能力或領導才能(1A)。此外，可以利用增潤及延伸所有科目課程內容，並在正規課堂實施合適的分組教學，照顧於個別學科表現出色的學生特定的學習需要(1B)(教育局，2019)。

第二層是校本抽離式計劃，在學校層面推行，主要對象為於特定學科或跨學科表現出色的學生。在這個階段，抽離式適異課程和計劃設計的對象為擁有特別才能或於學科表現出色的學生(2C)，以及於某特定範疇表現出色的學生(2D)(教育局，2019)。

第三層則是校外支援，意指為特別資優的學生提供正規學校以外的學習機會，接受專門性訓練(3E)(教育局，2019)。

### 資優教育的三大元素

三層架構推行模式其中一個主要特點是融合三大元素(高層次思維技巧、創造力、個人及社交能力)於本地學校的增潤課程中(教育局，2000)。實際上，三大元素與香港課程改革強調的九項共通能力環環緊扣。首先，創造力、批判性思考能力、運算能力、解難能力、以及研習能力有助培養高層次思維技巧。其次，溝通能力、協作能力、自我管理、正面的價值觀和態度與個人及社交能力有密切聯繫。下文將會從認知層面和情意層面分析三大元素的主要特質。

### 認知層面：高層次思維技巧

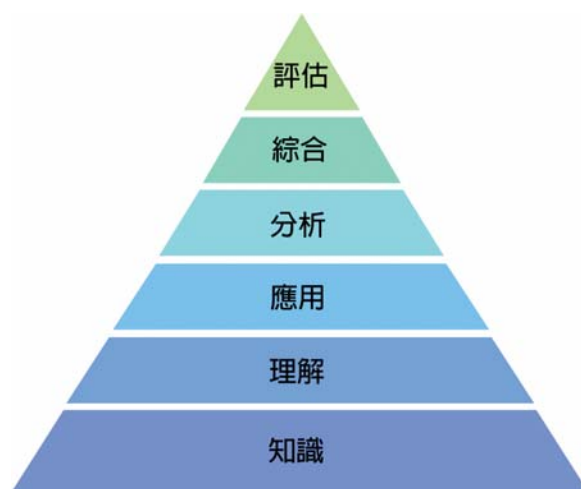
高層次思維技巧是指有組織的思考策略，根據Bloom's Taxonomy (1956) (圖6)，認知範疇的六大主要類別為知識 (Knowledge)、理解 (Comprehension)、應用 (Application)、分析 (Analysis)、綜合 (Synthesis) 及評估 (Evaluation) (Bloom, Engelhart, Furst, Hill, & Krathwohl, 1956)。這些類別由淺至深、具體至抽象排列，在這個分層框架下，要掌握越複雜的層次，必須先掌握到前一個較簡單的層次 (Krathwohl, 2002)。

Anderson et al. (2001) 按 Bloom 提出的理論修訂了有關認知範疇的分類學，將原本提出的知識、理解、應用和分析類別保留並改稱為記憶 (Remembering)、理解 (Understanding)、應用 (Applying)、分析 (Analyzing)。在更高的層次，綜合 (Synthesis) 改為評估 (Evaluating)，而評估 (Evaluation) 則為創造 (Creating)，是認知範疇六個層次中位於最頂端的 (Anderson et al., 2001; Wilson, 2019) (圖7)。

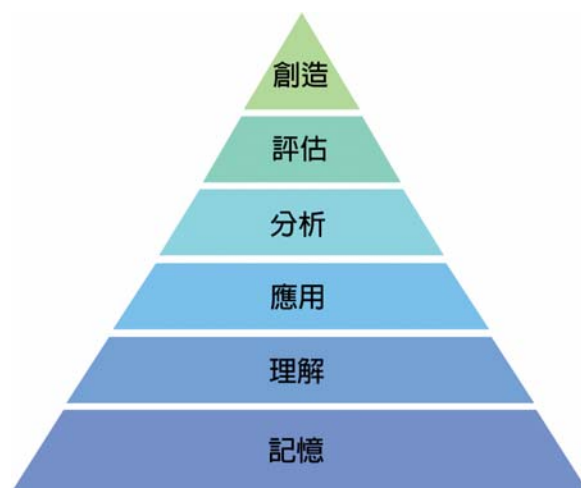
### 認知層面：創造力

創造力是指「(1) 擴展已掌握的技能，並應用在新的環境中；(2) 以創新策略面對問題；(3) 為沒有明顯解決方法的問題不斷尋找答案；(4) 在已有的說法或資料基礎上加以發揮；以及 (5) 嘗試以不同的答案去解答問題」(教育局，2019)

Olatoye, Akitunde及 Ogunsanya (2010) 發現創造力的重要性在於可以讓人們充分運用自己的人生經歷和資源，並且有助提升自信心、提出新想法、新概念和機遇，推動創新。他們認同創造力是智力、知識、動力、認知方式、性格和環境相互作用的成果，因此創造力是任何教育制度的核心元素 (Olatoye et al., 2010)。同樣地，在 Sternberg (2003) 的成功智能理論中亦提到，分析、創造和應用技巧皆是學校重視的能力。



圖六：布魯姆分類學中的六項主要認知範疇



圖七：布魯姆分類學中的認知範疇（修訂版）



創意思維的概念是指一個人擁有多方面的思維能力，而創意思維教學策略目的在於培育一個人的敏覺力、流暢力、變通力、獨創力及精進力，以下將會分別詳述：

- (1) 敏覺力：察覺缺漏、改變、有待處理、不尋常及未完成部分的能力；
- (2) 流暢力：能夠想出很多點子，反應敏捷，以及不斷湧現新觀念；
- (3) 變通力：改變思考方式、擴大思考類別、突破思考限制的能力，有變通力的人能夠從不同的觀點思量事物；
- (4) 獨創力：能夠給予一種不同凡響的答案、新穎的想法，有獨創力的人可以做出別人意想不到或與眾不同的事情；
- (5) 精進力：能在原構想或基本觀念的基礎上發展新意念，增加有趣細節，和組成相關概念群，擁有精進力的人會鞭策自己精益求精 (教育局，2019)。

### 情意層面：個人及社交能力

個人及社交能力是指個人對自己的態度 (自我概念)、對別人的態度 (與同儕、父母及長輩相處)、自己的信念、價值觀及對社會的關心 (教育局，2019)。有文獻指出資優學生更易在情緒及人際關係上出現適應困難的問題，他們的心智會較同齡朋輩早熟，但在情緒和體能發展未必與智能發展相稱。有見資優生可能會遇上不同形式的情緒和社交上的適應困難，資優學生會表現出完美主義傾向、情緒敏感、情緒過度興奮以及感到與朋輩不同，因此在課程上融入情意的元素對解決他們不同的需要尤其重要 (Chan, 1999, 2003; Peterson, 2015; Silverman, 1994; 教育局，2019; 張玉佩，2001; 郭靜姿，2000, 2013)。

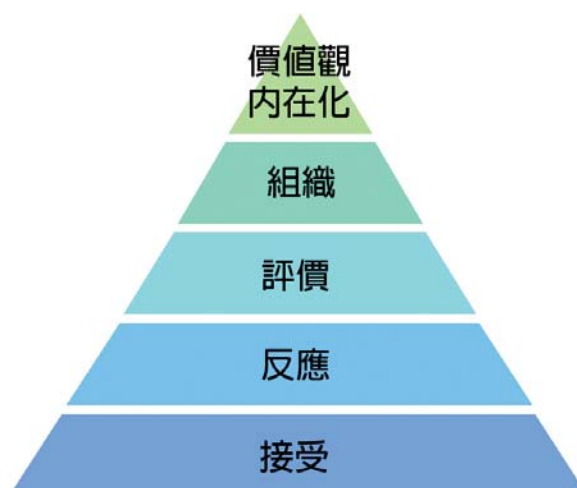
總結來說，培育創造力和高層次思維技巧可以解決學習需要，而提升個人及社交能力可以輔助資優和高能力學生發展情意特質。由此可見，制定校本課程可以讓教師或輔導員有效地支援資優生的情緒、社交、及/或動力/認知發展。基於此考慮，調整課程預期可以提高高能力學生的情意知識和能力 (VanTassel-Baska, Cross, & Olenchak, 2009)。

### Bloom's Taxonomy 分類學中的情意範疇

理論提及到情意範疇的五大主要類別 (圖8)，在最低的層次，接受 (Receiving) 圍繞專注和願意聆聽他人，並給予尊重 (Krathwohl et al., 1964)。第二個分類是反應 (Responding)，這個層次的重點在於學生主動參與學習的過程，而學習成果強調遵從指示作反應、願意作出反應、以及滿意作出的反應 (Krathwohl et al., 1964)。第三個分類是評價 (Valuing)，意指一個人對特定現象或行為給予的評價，簡單的舉動如接受價值或信念，甚至是一些較複雜的程度如作出承諾或化為信念。簡單來說，評價是一個深入內在化的層次 (Krathwohl et al., 1964)。緊隨其後的下一個層次是組織

(Organizing)，當一個人成功內在化價值觀，就能夠在不同情況中運用多於一種相關的價值觀，因此透過比較不同的價值觀，以及解決當中的矛盾，從而按優次整理這些價值觀，並且建立一個獨有的價值觀系統才是最重要的。這個層次注重比較、連繫以及綜合不同的價值觀 (Krathwohl et al., 1964)。

最後，位於最頂端的層次是內在化的價值觀。在這個層次，「價值觀早已在一個人的價值觀架構中有不同的位置，並且組織成一種連貫的內在系統，已經有一段長時間控制着該人的行為」(Krathwohl et al., 1964, p.165)。結果這種行為會變得普遍、一致，以及成為學生最重要的特質。



圖八：布魯姆分類學中的五項主要情意範疇

## 校本資優教育：學與教資源套

### 賽馬會「知優致優」計劃簡介

為了培育資優和高能力學生，以及提升校本人才發掘模式和培育課程的專業能力，賽馬會「知優致優」計劃致力為二十所計劃學校在2017至2019年度提供校本支援，範圍包括學校發展、專業發展、課程發展、學生發展及家長賦權。

計劃的其中一個顯著影響在學校發展方面，與計劃學校合作檢討和審視學校的長處和需要，以及制定校本才能發展和資優教育政策，配合學校的發展計劃和年度規劃，通過實踐經驗和緊密合作，促進學校落實資優教育政策為學校未來發展的其中一個主要方向。另一個重要變化是透過成立校本學生資料和才能數據庫，讓學校能夠辨識學生獨特的特質和潛能，從而為高能力和資優學生構思和建立適異課程及抽離式計劃。

在專業發展方面，計劃為學校教育人員提供專業培訓，並會邀請本地專業學者及海外知名資優教育學者主持。而且，早前舉行的資優教育講座系列及「適異性教學」專題講座暨實作工作坊成果也非常顯著。這些活動加強學校領導層在推行校本才能發展和資優教育方面扮演的角色，更證實能有效地增進教師對資優教育的知識，以及改善針對資優和高能力學生需要的教學策略。同樣地，「以實證為本方法提升學與教效能」工作坊加深教師對實證為本學習法的認知，及加強他們進行行動研究的能力，以評估學習效能。

再者，以創造力和情意教育為題的聯校教師發展日亦取得豐富的成果，有助學校同工和教師將創造力和情意元素融入資優教育的課程中。

值得一提的是當專業能力備受提升，就能推動計劃學校實踐資優教育的理論和策略。與賽馬會「知優致優」計劃的合作，讓學校在常規課堂的增潤課程教學中加入核心資優教育三大元素，包括創造力、高層次思維技巧及個人及社交能力 (L1)。再者，學校會因應學生的認知和情意需要及在校內的特質，發展及試驗適異課程、教學法和評估模式。學校為了滿足資優和高能力學生的特別教育和心理需要，進一步應用資優教育理論，並為不同科目制定校本適異課程和抽離式計劃 (L2)，包括小學的中國語文科、英國語文科、數學科和常識科，以及中學的數學科和綜合科學科。

為了全面呈現課程和計劃發展的概況，此資源套收錄了大量資優教育理論和學與教策略、課堂規劃、實踐過程、反思學習成果、以及實證為本的評估。另外亦附有實用的教學資源，以及學習成果的實例。總括而言，整合和出版此資源套大大提升賽馬會「知優致優」計劃的社會影響，而最重要的是通過本地學校成功經驗的分享，大力推動校本資優教育的發展至更多的學校。

### 出版資源套之目的

賽馬會「知優致優」計劃與學校管理層和前線教師合作，實踐全班式增潤課程 (L1) 和抽離式計劃 (L2)，對象包括常規課堂的學生十五所小學裏於中國語文科、英國語文科、數學科和常識科表現優秀的高能力和資優學生、以及五所中學裏於數學科和綜合科學科表現優秀的高能力和資優學生。《校本資優教育：學與教資源套》的出版，屬專業協作及支援校本資優教育之成果，目的包括：

- 透過各教育同工、課程領導、校長及教師之學與教經驗分享，推動香港資優教育發展；
- 透過學校間之專業分享，鼓勵教師專業發展，以提升教師施行校本資優教育的效能；
- 分享全班式及抽離式課程的成功經驗，提升學生潛能；及
- 提供平台讓校長、教師及教育同工，反思其校本資優教育政策和課程。

### 資源套的內容編排

《校本資優教育：學與教資源套》共有五冊，挑選了共三十二個第一和第二層的成功示例作分享。第一至四冊分別收錄了二十四個示例，涵蓋小學的中國語文教育、英國語文教育、數學教育和常識課程。而第五冊則收錄八個示例，包括中學的數學和科學教育課程。

資源套由前言、教案、學與教資源及學生作品範例組成，為了讓讀者有更全面的認識，第一層架構中的每個課程單元將會詳細討論協作背景和目標、理論框架、課堂設

計原理、資優教育的學與教策略，並在討論部分，分析實際經驗和學習實證，作出反思和成效檢討，而教案、學與教資源及範例則會以附錄形式供教師參考和使用。第二層架構的抽離式計劃，除了上述的部分外，亦會詳述挑選學生對象的準則和程序，以及特定的學習內容和活動。

### 給課程領導及教師的建議

此資源套的製作專門為計劃學校的學生而設，以符合他們特定的認知和情意需要。在使用有關資源時，應考慮學校校情及學生特性，作出調整。我們期待教育同工能因應學生的特質和興趣，將計劃提供之教學資源，結合學與教經驗，設計合適的學習活動，融入資優教育元素，讓學生展現潛能，培育成才。

為鼓勵和推動學校在未來計劃和發展校本資優教育課程，賽馬會「知優致優」計劃亦同時準備了網上版的資源套，以及將其他學與教的資源於網上刊載。《校本資優教育：學與教資源套》的更多詳情，請瀏覽計劃的網頁 (<https://www.fed.cuhk.edu.hk/gift>)。

# Introduction

The issue of this *School-based Gifted Education: Learning and Teaching Resource Package* was the fruitful outcome of the professional collaboration between the **Jockey Club “Giftedness into Flourishing Talents” Project** (Project GIFT) and 20 local Project Schools (15 primary and 5 secondary schools) in 2017/2018 and 2018/2019. The Project was launched by the Centre for University & School Partnership, Faculty of Education, The Chinese University of Hong Kong (CUHK) with funding from the Hong Kong Jockey Club Charities Trust to promote school-based talent development and gifted education in Hong Kong. It was a cross-institutional effort by research investigators from CUHK, the Hong Kong Polytechnic University, the City University of Hong Kong, and the Education University of Hong Kong.

To enhance readers’ knowledge of gifted education implementation and school-based professional collaboration with Project Schools, this chapter serves four main purposes. First of all, the primary focus will be on the contemporary perspectives on giftedness. To this end, the conception and theoretical models of giftedness will be examined. Then, to nurture children with giftedness and talents, gifted education strategies will be elaborated. Following this, the development of gifted education in Hong Kong, together with a three-tier implementation model and the core elements of gifted education will be discussed. After that, the background of professional collaboration, the purposes and major components of this *School-based Gifted Education: Learning and Teaching Resource Package* will be introduced.

With this resource package, we aim at providing local primary and secondary schools with an effective platform for dissemination and sharing of learning and teaching resources. Most importantly, we look forward to providing educators, teachers, curriculum leaders, and school administrators who are interested in gifted education with a rich source of good practices of school-based enriched curriculum and talent development (L1) as well as pull-out programmes for high ability and gifted students (L2).

## Contemporary Perspectives on Giftedness

### What is giftedness?

Giftedness has long been defined by intellectual intelligence or the psychometric IQ score. It was no surprise then that western IQ tests were considered as indicators to identify giftedness (Chan, 2018). Nevertheless, over the years, the conception of giftedness and intelligence has undergone remarkable changes. IQ score is no longer regarded as “an adequate measure of giftedness” (Chan, 2018, p.73). Rather, a broad definition of giftedness using multiple criteria is adopted.

Based on the U.S. Marland’s Report (1972), which supported a multi-faceted or multi-dimensional



nature of giftedness, the Education Commission Report (1990) identified the definition of giftedness and addressed the educational needs of gifted children in Hong Kong. Accordingly, gifted children are those who show exceptional achievement or potential in one or more of the following.

- (a) A high level of measured intelligence;
- (b) Specific academic aptitude in a subject area;
- (c) Creative thinking showing high ability to invent novel, elaborate and numerous ideas;
- (d) Superior talent in visual and performing arts such as painting, drama, dance, music, etc;
- (e) Natural leadership of peers showing high ability to move others to achieve common goals; and
- (f) Psychomotor ability demonstrating outstanding performance or ingenuity in athletics, mechanical skills or other areas requiring gross or fine motor coordination (Education Commission, 1990, p.47).

### Theoretical Models of Giftedness

Two main theoretical models are relevant and consistent with the Asian cultural conception of giftedness. The first one is Renzulli's (1978) Three-Ring Model (Figure 1). The second one is Gardner's (1983) Theory of Multiple Intelligences (MI) (Figure 2). They will be examined as follows.

The Three Ring Conception of Giftedness holds that gifted behavior is an outcome of the interaction of three basic clusters of human traits, namely, above average general and /or specific abilities, high levels of task commitment (motivation), and high levels of creativity.

One of the major components is well-above average ability. On the one hand, general ability consists of traits that can be applied across all or broad domains. It is the "capacity to process information, to integrate experiences that result in appropriate and adaptive responses to new situations, and the capacity to engage in abstract thinking" (Renzulli, 2010, p.259). Therefore, verbal and numerical reasoning spatial relations, memory as well as word fluency are examples of this general abilities. On the other hand, specific abilities range from "the capacity to acquire knowledge, skill, to the ability to perform in one or more activities of a specialized kind and within a restricted range" (Renzulli, 2010, p.260).

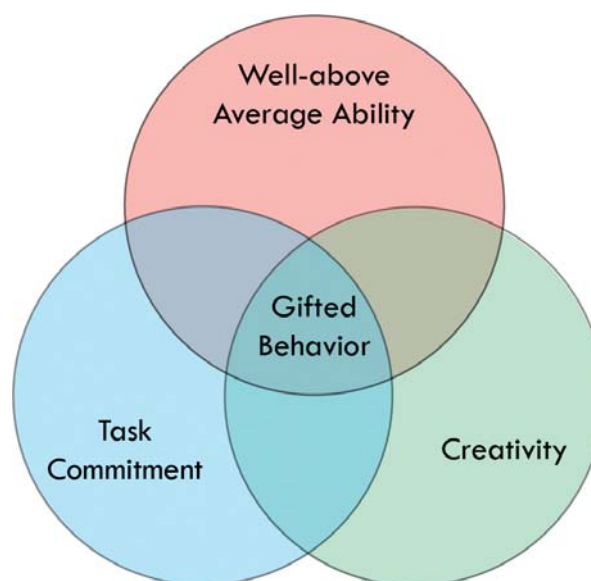


Figure 1. Three ring conception of giftedness  
(Adapted from Renzulli, 1978, p.83)

Task Commitment is the second feature. It represents energy brought to bear on a particular problem or specific performance area. Task commitment has been found to be strongly associated with one’s perseverance, endurance, hard work, dedicated practice, self-confidence, belief in carrying out important work, and action applied to his/her area of interest. In general, task engagement can be either intrinsically or extrinsically motivated (Renzulli, 2010).

Creativity is the third of the cluster of traits that characterize one’s giftedness. Its vital role in the cognitive process has been supported in the revised Taxonomy of Anderson et al. (2001). In their model, six levels of cognitive domains are stipulated, namely Remembering, Understanding, Applying, Analyzing, Evaluating, and Creating. Among them, creativity belongs to the highest level of the cognitive hierarchy.

In brief, gifted children possessing the above-mentioned traits are “capable of developing and applying themselves to any potentially valuable area of human performance” (Chan, 2018, p.74). It is interesting to note that the focus on one’s ability and task commitment shares the same mindset

of “effort and hard work” with Confucian ideology. According to Confucian teaching, one’s ability is highly regarded especially in Chinese communities. As regards creativity, however, it is commonly agreed that the collectivist values of Confucianism such as conformity and obedience are not conducive to the nurturing of creativity. As such, to cultivate giftedness in children, researchers find that the promotion of creativity is always a top priority in many Asian countries, notably China, Hong Kong, Singapore and South Korea (Chan, 2018; Hui & Lau, 2010).

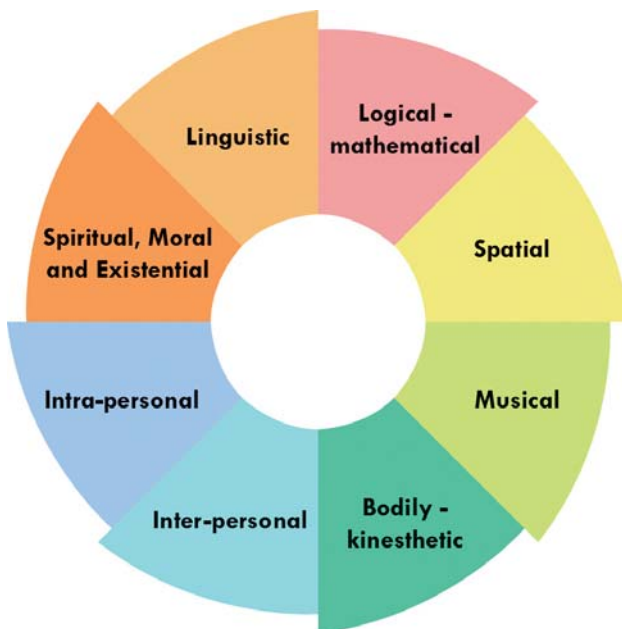


Figure 2. The theory of multiple intelligences

While most studies correlate giftedness with intelligence, some theorists have developed new models of intelligence. To Gardner (1983), intelligence is not a unitary concept.

Rather, there are various dimensions of intelligences. In his initial model, Gardner formulated the seven dimensions of intelligences, namely linguistic, logical-mathematical, spatial, musical, bodily-kinesthetic, inter-personal, and intra-personal. Later, he added an eighth one named spiritual, moral and existential intelligence (Gardner, 1999). This new conception has marked a great difference from the traditional notion of giftedness, which pays great attention to intellectual intelligence.

In sum, the MI theory matches well with the Confucian educational ideal of promoting students’ balanced development in the ethical (de), intellectual (zhi), physical (ti), social (qun) and aesthetic



(mei) domains (Chan, 2008). Similarly, Sternberg and Reis (2004) hold that giftedness involves more than just IQ. Instead, it has both non-cognitive and cognitive components. Sternberg and O'Hara (1999) suggested that intelligence is simply one of the six forces that generate creative thought and behavior. It is the confluence of intelligence, knowledge, thinking styles, personality, motivation, and the environment that forms gifted behavior as viewed from a creative-productive perspective. In addition, Renzulli (2010) also supported an expanded conception of giftedness. Instead of adopting a purely academic definition, he reiterated the value of “multiple talent” and “multiple criteria” in understanding the characteristics of high potential and gifted students.

## Approaches to Differentiated Education

Gifted and talented children demonstrate distinct learning styles that call for a diversity of educational offerings. Gifted learners generally demand rich “learning experiences which are organized by key concepts and principles of a discipline rather than by facts” (Tomlinson, 2019, p.1). Compared with their non-gifted counterparts, gifted children are inclined to master advanced material in a complex and abstract manner earlier and more consistently than their peers (Brody & Benbow, 1987; Little, 2018).

Given the unique characteristics and needs of gifted learners, the adoption of differentiated instruction is in alignment with the Confucian value of “yin-cai-shi-jiao” (teaching according to one’s abilities). As such, differentiation allows instructors to teach in accordance with each one’s abilities and needs.

### Differentiation

Differentiation is “the process of making educational expectations match individual students’ different learning needs” (Matthews & Foster, 2009, p.112). This strategy is proved to be effective in serving gifted learners especially in heterogeneous classrooms. At the curriculum level, adaptations can be made by removing unnecessary or repetitive chunks of content, reorganizing or intensifying content, and connecting a unit of study to other subject areas or disciplines. At the classroom level, teachers may adopt flexible grouping based on students’ strengths, interests and weaknesses, and extend the breadth and depth of learning experiences (Wan, 2016).

Differentiated provisions are typically essential to the gifted or talented individuals who exhibit differential abilities and multi-level talents. Their educational needs can be appropriately satisfied with accelerated, compacted and advanced learning content, and enriched learning experiences, which help develop convergent and imaginative abilities, and pursue higher goals and independence (Feldhusen, 1982; Griggs & Dunn, 1984; Tomlinson, 1994; VanTassel-Baska & Stambaugh, 2005). In the discussion below, differentiated curriculum, instruction as well as assessment will be examined.

### Differentiated Curriculum

To start with, in the regular curriculum, the Schoolwide Enrichment Model (SEM, Renzulli, 2003; Renzulli & Reis, 1994, 1997; Renzulli & Renzulli, 2010) (Figure 3) proposes differentiation of

textbook contents, processes and products to accommodate the diverse needs of individual learners. In particular, teachers should adopt curriculum modification techniques that can (a) adjust levels of required learning so that all students are challenged, (b) eliminate boredom and increase challenge and engagement for all learners, and (c) introduce various types of enrichment into regular curricular experiences (Renzulli & Reis, 2014, p.48). Other researchers also recommend using the unique characteristics of the students as criteria for decisions on how the curriculum should be adapted and differentiated (Feldhusen, Hansen, & Kennedy, 1989; Maker & Nielson, 1996).

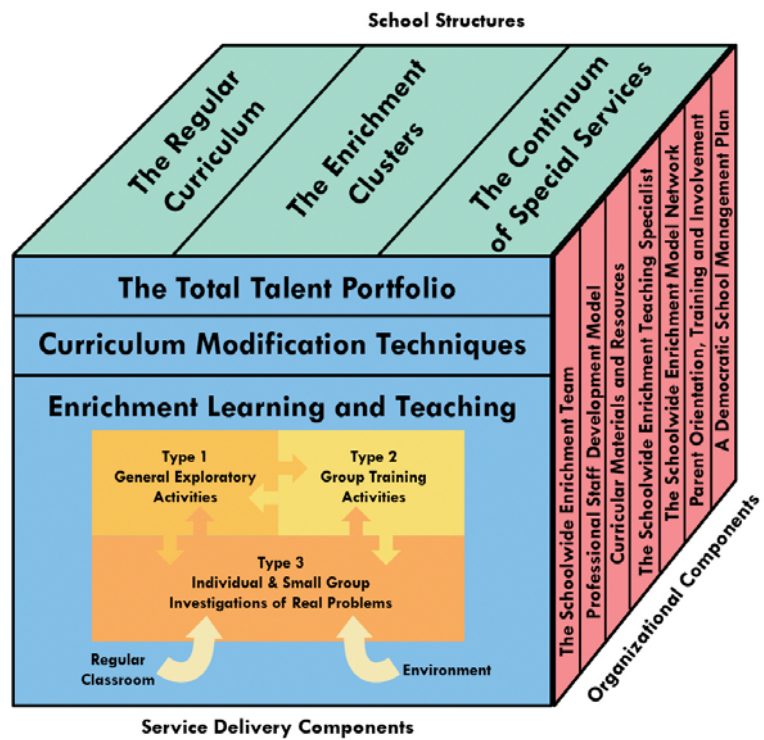


Figure 3. The schoolwide enrichment model  
(Adapted from Renzulli, 2003, p.6)

It is believed that effective teaching of gifted students happens at a higher degree of difficulty, independence and competency than for most students their age. Gifted learners are more likely to engage with a different level of challenge during instruction as compared with their average peers. In VanTassel-Baska’s (1986) view, advanced content is essential to provide gifted children with advanced stimuli so that they have extended opportunities to experience new learning and challenges. Therefore, to challenge the gifted and talented, teachers are recommended to adopt learning content, process and products that are more complex, more abstract, more open-ended, more multi-faceted than would be appropriate for many peers (Tomlinson, 2019).

Beyond the capacity for more advanced learning content, gifted children showed strong preference for more challenging learning experiences. At the classroom level, challenge may be defined by pace, depth and opportunities to engage with higher-order thinking and to pursue greater depths of difficulty around their own interests (Kanevsky & Keighley, 2003; Little, 2018).

The following will discuss key instructional practices and teaching strategies for promoting effective learning by addressing the intellectual characteristics and learning needs of learners with giftedness.

### Curriculum Compacting

One of the most widely used SEM differentiation strategies is curriculum compacting. It plays an essential part in incorporating content, process, products, classroom management, and teachers’

commitment to accommodate individual and small-group differences. Most importantly, it improves instruction by streamlining and provides more challenging learning opportunities for high-potential and talented learners. What is more, when formative assessments demonstrate that gifted learners have already mastered the teaching content and skills, instruction can skip over some content and move on to other advanced material. As a result, compacting curriculum facilitates the implementation of other instruction strategies in the classroom for gifted learners (Reis & Purcell, 1993; Rogers, 2007).

### Differentiated Instruction

Another unique feature of the SEM is differentiated instruction. It suggests the incorporation of a variety of within-classroom strategies in classrooms. Differentiation is an attempt to address the variation of learners in the classroom to match the individual needs of students (Tomlinson, 2000). In her view, “good teaching for gifted learners is paced in response to the student’s individual needs” (Tomlinson, 2019, p.1). Gifted and high ability children learn faster. On the one hand, they desire a more compact curriculum with accelerated instructional pace than their peers. On the other hand, they expect a faster learning pace that allows them to achieve a depth or breath of understanding, and to satisfy a bigger appetite for learning.

VanTassel-Baska’s (1986) Integrated Curriculum Model (ICM) (Figure 4) has laid down a framework to address the curricular needs of gifted learners. In the model, six main differentiation features are identified, namely abstractness, depth, complexity, creativity, acceleration, and challenge (VanTassel-Baska, 2003).

Acceleration and challenge are included to serve the target of advanced content. Using acceleration, “teachers pre-assess students to determine their readiness relative to certain skills, and may compact or compress new material at more advanced levels”. As an effective strategy, acceleration “encompasses a wide variety of approaches to intervention to gifted learners” (Little, 2018, p.374). Accelerated pace and content are made feasible by moving students into different grade levels, introducing advanced content earlier, as well as moving students faster through content (Assouline, Colangelo, & VanTassel-Baska, 2015).

Challenge involves using sophisticated content stimuli and advanced resources for student exploration (VanTassel-Baska & Chandler, 2013). Depth, complexity and creativity are the key features of the Process-Product Dimension. These

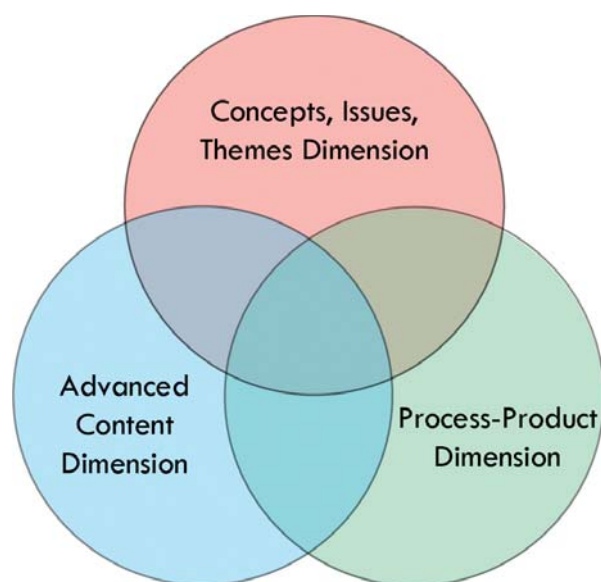


Figure 4. Integrated curriculum model

strategies help to address gifted students' characteristic of intensity, in terms of their ability to sustain focus of interest. Investigation in Depth demands one's original research and in-depth exploration from multiple perspectives. Similarly, complexity requires one's multiple higher order thinking skills and multiple variables to study a topic. Creativity addresses the intensity of the gifted learners through creative production for advanced learning.

One additional differentiation feature is abstractness. It is closely associated with the concepts/ issues/themes dimension of the ICM. By adopting abstractness in the curriculum, gifted learners are motivated to move from concrete examples to conceptual thinking skills and form generalizations independently.

In sum, the ICM provides a blueprint for structuring curriculum and planning instructional strategies for the learning and teaching of gifted students in a local context. It is particularly applicable in the Level 1 Gifted Education programmes (Three-Tier Model) which promote in-class differentiation in regular classrooms at local schools.

### **Grouping**

Past research has revealed the usefulness of grouping strategy in supporting gifted students. In particular, flexible grouping in regular classrooms supported the achievement and valued outcomes of gifted students (Rogers, 2007, Tomlinson, 2005). It is an instructional strategy where students are grouped together to receive appropriate challenging instructions based on diverse academic abilities, learning styles and interests. As Tomlinson (2005) commented, flexible grouping fosters students to taste variant learning experiences based on learners' characteristics, intellectual potential and learning styles.

In summary, the SEM, being one of the most widely used and evidence-based curriculum models in gifted education, provides inspirations for educators to look at each student's strengths, interests, learning styles, and preferred modes of expression and to capitalize on these assets when developing challenging learning opportunities for superior learners and highly motivated students (Renzulli & Reis, 2014). It aims to maximize talents of all students by adopting a whole school approach to develop the learning potential of all students with a conviction that "a rising tide brings up all ships" (Renzulli & Reis, 2014).

In this view, to stretch the potentials and to address the learning needs of the gifted learners, schools should provide them with a wide variety of educational opportunities, resources, and encouragement above and beyond those ordinarily provided through regular instructional programmes.

### **Differentiated Assessment**

It is worth noticing that curriculum, when differentiated, should be supplemented with diagnostic assessment, as proposed by the ICM. In addition to curriculum modifications based on the needs of gifted children, ongoing formative assessment ensures students are enhancing needed

competencies (VanTassel-Baska, 2018). Generally speaking, two models of assessment, namely performance-based assessments and portfolios, are recommended.

First, performance-based assessment requires students to demonstrate the qualities of higher level thinking, problem solving, creativity, as well as articulation in a task demand. Second, evaluation by portfolio asks students to select and present their best work. Most importantly, it is common practice that portfolios are showcased to parents and community. Further, this assessment tool allows gifted students to experience deeper insights into the learning process (VanTassel-Baska, 2008).

## Gifted Education in Hong Kong

### The Three-tiered Implementation Model

In the Hong Kong context, the Education Commission Report No. 4 (1990) stated that the vision of education is to cater for the learning needs of all students. The main targets of gifted education are to nurture and expand different potentials and to develop in every student his/her outstanding abilities through the provision of quality education. Therefore, all local schools should be committed to providing appropriate learning opportunities for talented and gifted students. School-based gifted education programmes and provisions are considered to be the most favorable approach to benefit gifted learners (Education Bureau, 2019).

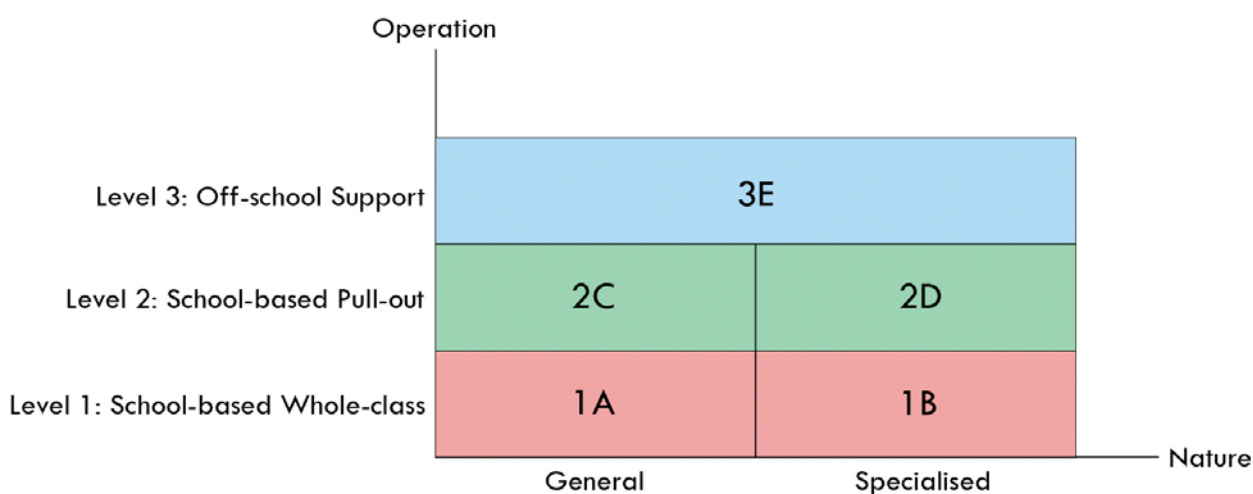


Figure 5. The three-tiered implementation model (Adapted from Education Department, 2000, p.6)

To meet the unique characteristics and learning needs of gifted students, the Three-tiered Model (Figure 5) has been adopted for the promotion of gifted education since 2000. More specifically, Level 1 refers to school-based whole-class teaching. It requires pedagogies to tap the potential of students in creativity, critical thinking, problem solving or leadership in regular classrooms. This target can be fulfilled by integrating the three core elements of gifted education (higher-order thinking, creativity and personal-social competence) into the enrichment curriculum of regular classrooms for all students (1A). In addition, the specific needs of those students with outstanding



performance in individual academic subjects are catered for by enriching and extending the curriculum across all subjects, and differentiating teaching through appropriate grouping of students (Education Bureau, 2019).

Level 2 refers to school-based pull-out programmes in disciplinary or interdisciplinary areas for students with higher ability within the school setting. At this stage, pull-out differentiated curriculum and programmes are designed for students with specific talents or outstanding academic results (2C) and for students demonstrating outstanding performance in specific domains (2D) (Education Bureau, 2019).

At Level 3, off-school support refers to provision of learning opportunities for exceptionally gifted students in the form of specialist training outside the school setting (3E) (Education Bureau, 2019).

### The Three Core Elements of Gifted Education

In the 3-tier model, one major feature is to incorporate the three key elements of higher-order thinking skills, creativity and personal-social components into an enriched curriculum at local schools (Education Department, 2000). In essence, the three elements share a close relationship with the nine generic skills as advocated in the Hong Kong curriculum reform. First, creativity, critical thinking, computation skills, problem-solving skills and study skills help to nurture higher-order thinking. Second, communication skills, collaboration skills, self-management skills, positive values and attitudes are closely associated with personal-social competence. In the following, the main characteristics of the three major elements will be examined in both cognitive and affective dimensions.

### Cognitive Dimension: Higher-Order Thinking

Higher-order thinking refers to organizing thinking skills. According to Bloom's Taxonomy (1956) (Figure 6), six major categories in the cognitive domain are knowledge, comprehension, application, analysis, synthesis, and evaluation (Bloom, Engelhart, Furst, Hill, & Krathwohl, 1956). The categories are ordered from simple to complex and from concrete to abstract. Under this hierarchical framework, the mastery of each simpler category is a prerequisite to mastery of the next more complex one (Krathwohl, 2002).

Anderson et al. (2001) revised the taxonomy of cognition based on Bloom's model. More specifically, the original knowledge, comprehension, application

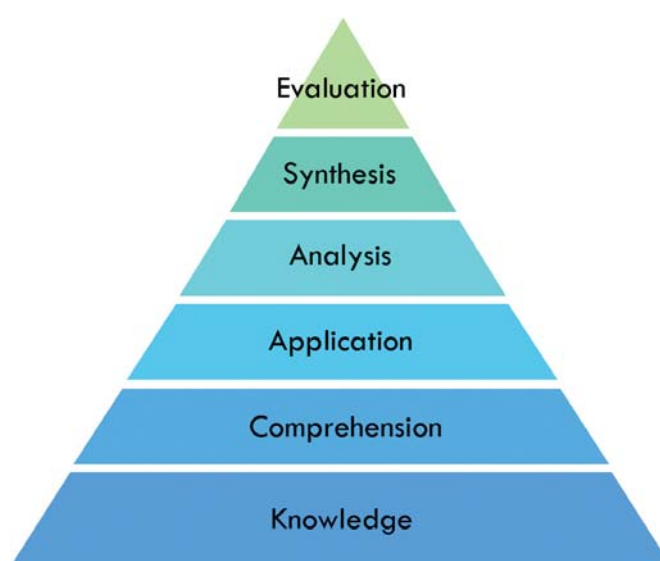


Figure 6. Six major categories in the cognitive domain of Bloom's taxonomy

and analysis categories were retained and renamed as remembering (knowledge), understanding (comprehension), applying (application) and analyzing (analysis) respectively. At the higher levels, synthesis was changed to evaluating whereas evaluation was revised as creating, which was made the top category amongst the six levels of cognitive domains (Anderson et al., 2001; Wilson, 2019) (Figure 7).

### Cognitive Dimension:

#### Creativity

Creativity refers to “(1) expanding mastered skills, and applying them to new environments; (2) confronting problems with original strategies; (3) continuously seeking answers to questions that have no apparent solutions; (4) elaborating on established theories or information; and (5) trying to solve problems with different solutions” (Education Bureau, 2019).

Olatoye, Akitunde, and Ogunsanya (2010) found creativity essential, for it allows people to make the most of their life experiences and their resources. Additionally, it increases self-confidence, produces ideas, new concepts and opportunities for innovation. They supported that creativity is the result of interaction between intellectual work, knowledge, motivation, cognitive styles, personality and environment. As a result, it constitutes the central element of any educational system (Olatoye et al., 2010). Similarly, Sternberg’s (2003) theory of successful intelligence stated that analytical, creative and practical skills are important abilities in schools.

Creative thinking is conceptualized as one’s ability for divergent thinking. The creative thinking approach aims to develop one’s sensitivity, fluency, flexibility, originality and elaboration skills. They are be elaborated as follows.

- (1) Sensitivity: It is the ability to detect omissions, modifications, things yet to be done, and unusual or unfinished processes.
- (2) Fluency: It is the ability to make many suggestions, to react promptly, and to enable new ideas to constantly emerge.
- (3) Flexibility: It is the ability to change thinking modes, to expand one’s thinking style, and think outside the box. A flexible person can contemplate things from different viewpoints.
- (4) Originality: It is the ability to offer extraordinary answers and novel ideas. An original individual performs unexpected and unconventional tasks.

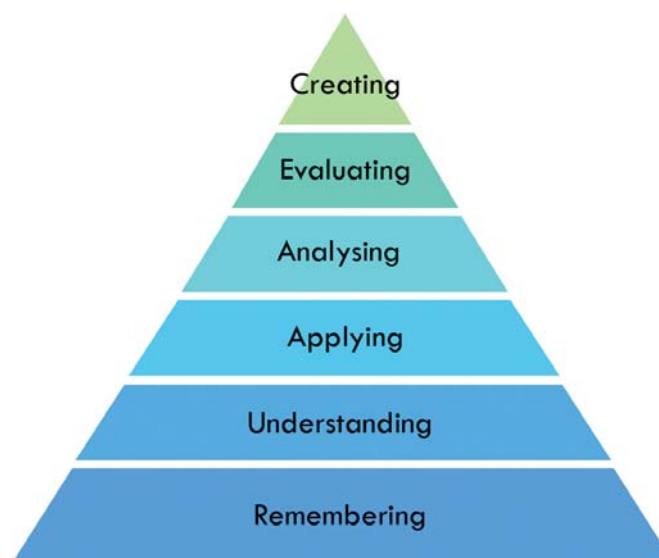


Figure 7. The revised model of Bloom’s taxonomy of cognition



- (5) Elaboration: It is the ability to use raw thoughts to expand new ideas, add interesting details, and incorporate them into a relevant cluster of concepts. An elaborative power makes an individual strive for better work outcomes through continuous improvement (Education Bureau, 2019).

### **Affective Dimension: Personal-Social Competence**

Personal-Social Competence is conceptualized as one's attitude towards one's self (self-perception), one's attitude towards others (relationships with siblings, peers, parents and elders), and one's convictions, values and concerns about society (Education Bureau, 2019). A review of the literature has reflected that gifted students are more likely to encounter maladjustment in emotions and inter-personal relationships. They are found to be more mentally developed than their peers. However, their emotional and physical development may not match their pace of intellectual growth. Given that gifted individuals may encounter different forms of emotional and social maladjustments, the integration of an affective component into the curriculum is particularly important to address the diverse needs of gifted students, who manifest perfectionism, emotional sensitivity, emotional over-excitability, and feel differently from their peers (Chan, 1999, 2003; Peterson, 2015; Silverman, 1994; 教育局, 2019; 張玉佩, 2001; 郭靜姿, 2000, 2013).

To conclude, the nurturing of creativity and higher order thinking caters for learning needs whereas the strengthening of personal and social competence meets the affective characteristics of the gifted and talented learners. In view of this, it is vital to develop a school-based curriculum to support their emotional, social/interpersonal, and /or motivational/cognitive development by school teachers and counsellors. Under this consideration, curriculum adaptations are expected to enhance the affective knowledge and skills of the high-ability students (VanTassel-Baska, Cross, & Olenchak, 2009).

### **Affective Domain of Bloom's Taxonomy (Krathwohl, Bloom, & Masia, 1964)**

In the model, five major categories of affective domain are identified (Figure 8). At the bottom level, receiving involves awareness and willingness to attend and to listen to others with respect (Krathwohl et al., 1964). The second classification is responding. At this level, active participation on the part of the learners is the main focus. Learning outcomes may emphasize compliance in responding, willingness to respond, or satisfaction in responding (Krathwohl et al., 1964).



Figure 8. Five major categories in the affective domain of Bloom's taxonomy

The third category is valuing. It means the worth or value a person attaches to a particular phenomenon, or behavior. This ranges from simple acceptance of a value/belief to a more complex state of commitment or conviction. In brief, valuing represents a stage of deeper internalization (Krathwohl et al., 1964). The next stage is organization. It is assumed that when one successfully internalizes values, one encounters situations for which more than one value is relevant, consequently, organizing values into priorities by contrasting different values, resolving conflicts between them, and creating an unique value system is necessary. This category puts much stress on comparing, relating, and synthesizing values (Krathwohl et al., 1964).

Lastly, the highest stage is internalizing values. At this level of internalization “the values already have a place in the individual’s value hierarchy, are organized into some kind of internally consistent system, have controlled the behavior of the individual for a sufficient time” (Krathwohl et al., 1964, p.165). As a result, such behavior is pervasive, consistent, and the most important characteristic of the learner.

## **School-based Gifted Education: Learning and Teaching Resource Package**

### **Introduction of Project GIFT**

To nurture children with giftedness and talents and to enhance the professional competence of school personnel in talent development and gifted education, Project GIFT was committed to providing the 20 Project Schools with school-based support in the areas of school development, professional development, curriculum development, student development as well as parent empowerment during the period 2017-2019.

One remarkable impact of the Project was on school development. More specifically, the Project collaborated with Project Schools to review and assess the strengths and needs of the schools and to formulate school-based talent development and a gifted education policy in line with Schools’ Development Plans and Year Plans. Through practical experiences and close collaboration, schools were motivated to adopt a gifted education policy as one of the main directions of future school development. Another significant change was that by developing a school-based talent search database, the schools were capable of identifying the unique characteristics and potentials of their students. Consequently, they proceeded to explore and develop differentiated curricula and pull-out programmes for students with high learning potential and giftedness.

As regards professional development, the Project contributed in offering school personnel professional training by local professional academicians and overseas world renowned scholars in gifted education. More specifically, the Gifted Education Lecture Series and the Thematic Seminars cum Workshops on Differentiation were arranged with fruitful results. The programmes were generally successful in enhancing school leaders’ roles in promoting and orchestrating school-based talent development and gifted education. Moreover, they were found effective in advancing teachers’ professional knowledge of gifted education and their strategies to cater for students with

giftedness or high ability. Likewise, the “Evidence-based Practice and Action Research Workshop” deepened teachers’ understanding of evidence-based learning and enhanced their competency in conducting action research to facilitate assessment for learning. Furthermore, the Joint School Staff Development Days on Creativity and Affective Education yielded promising results with enhanced skills in infusing creativity and affective elements into a gifted education curriculum among school leaders and teachers.

It is worth mentioning that with such strengthened professional capacity, the Project Schools were motivated to put gifted education theories and strategies into practice. In collaboration with the Project, they integrated the core elements of creativity, higher-order thinking and personal-social development into an enriched curriculum for students in regular classroom teaching (L1). Further, they developed and tried out the differentiation curriculum, instruction and assessment based on students’ cognitive and affective needs and characteristics at their respective schools. Most importantly, to cater for the unique educational and psychological needs of the children with giftedness and high ability, the schools took the instrumental step of adapting the gifted education theories and tailor making a school-based differentiated curricula and pull-out programmes (L2) for Chinese Language Education, English Language Education, Mathematics Education and General Studies in primary schools, and Mathematics Education and STEM Education in secondary schools.

With a view to presenting a comprehensive picture of the curriculum/programme development, in this resource package, the rich content of gifted education theories and strategies, lesson design, implementation process, reflective outcomes, as well as evaluation based on evidence of learning are recorded. Additionally, useful learning and teaching resources with samples of learning outcomes are attached. In sum, the compilation and publication of this resource package fosters maximizing the Project’s social impact. Most importantly, it helps to promote the widespread development of school-based gifted education through dissemination of good practices among local schools.

### **Purposes of publishing this Resource Package**

Project GIFT collaborated with school management and frontline teachers to develop an enriched curriculum (L1) and pull-out programmes (L2) for students in regular classroom learning and students with high ability or giftedness in Chinese Language Education, English Language Education, Mathematics Education, General Studies in 15 primary schools and Mathematics and Science/STEM Education in 5 secondary schools.

The publication of this *School-based Gifted Education: Learning and Teaching Resource Package* is the successful outcome of professional collaboration and school-based support. It aims:

- To promote the development and implementation of Hong Kong’s gifted education through dissemination of good practices among educators, curriculum leaders school principals and frontline teachers;
- To motivate teachers’ professional development and advance teachers’ capacity through professional sharing and exchange;

- To share and disseminate the successful development and implementation of a school-based enriched curriculum for regular classes and accelerated pull-out programmes for students with high intellectual ability and giftedness; and
- To provide opportunities for reflection by principals, teachers and related parties on how to build on their strengths and experiences in schools' gifted education policy and curriculum.

### **Organization of the Resource Package**

This *School-based Gifted Education: Learning and Teaching Resource Package* is made up of a series of 5 booklets. A total of 32 successful exemplars of L1 and L2 curriculum are selected for dissemination. Books I - IV contain collection of 24 exemplars of Chinese Language Education, English Language Education, Mathematics Education, as well as General Studies from primary schools. Book V presents 8 exemplars of Mathematics and Science/STEM Education from secondary schools.

Each learning and teaching resource is composed of a Foreword, Lesson Plan, Learning and Teaching Resources, as well as samples of Student Work. To provide readers with a more comprehensive picture of all L1 enriched curricula, the background and objectives of collaboration, theoretical framework, rationale for programme / lesson design, gifted education learning and teaching strategies will be discussed in detail. Following this, reflection and evaluation based on practical experiences and evidence of learning will be examined in the discussion part of the Foreword. After that, the lesson plan, learning and teaching resources and samples of good practices are provided in the Appendices for teachers' adaptation and reference. For L2 pull-out programmes, in addition to the above-mentioned components, selection criteria and procedures for target students as well as the specific learning content and activities will also be elaborated.

### **Recommendations for School Curriculum Leaders & Teachers**

This resource package is developed and tailor made to meet the specific cognitive and affective needs and characteristics of students of the Project Schools. To enhance learning and teaching effectiveness, teachers are strongly recommended to make necessary curriculum, instructional and assessment modifications in accordance with the diverse needs and abilities, learning styles and aspirations of students, professional competence of teachers, and gifted education development of your schools when adapting this resource package.

To encourage and motivate schools to plan and develop a school-based gifted education curriculum in the near future, Project GIFT has prepared a web version of the resource package as well as other learning and teaching resources. Further details of the *School-based Gifted Education: Learning and Teaching Resource Package* will be uploaded to our website (<https://www.fed.cuhk.edu.hk/gift>).

數學科 第一層

校本全班式  
教學




Mathematics Level 1  
School-based  
Whole-class  
Teaching



# Percentage - Discount

**Grade: Secondary 1**

**No. of Lessons (Learning Time): 2 Consecutive Lessons (60 minutes)**

<b>Prior Knowledge</b>	Basic operations of percentages and percentage changes
<b>Learning Objectives</b>	<ul style="list-style-type: none"> <li>- Students can acquire Mathematical language in conveying information, including the understanding of keywords 'marked price', 'selling price', 'discount' and 'discount percentage', and interpreting different ways of presentation about discount in daily life</li> <li>- Students develop Mathematical reasoning skills, including the comparison of discount percentage in different cases with suitable calculations, and exploring the change in the discount percentage when the prices and quantity change</li> <li>- Students develop collaboration skills through collaborating with others</li> </ul>
<b>Intended Learning Outcomes</b>	<ul style="list-style-type: none"> <li>- Students can present correct solutions to most questions in worksheets</li> <li>- Students demonstrate creativity by giving different answers in worksheets</li> <li>- Students understand and correctly use the keywords about discounts throughout the lesson</li> <li>- Students participate actively in group discussions</li> <li>- Students feel challenged when seeing the non-routine problems and persist in solving them</li> </ul>
<b>Learning &amp; Teaching Strategies</b>	Mixed-ability Grouping
<b>Operation Mode of Gifted Education</b>	Level 1: School-based Whole-class Teaching
<b>Core Elements of Gifted Education</b>	<ul style="list-style-type: none"> <li> Higher-order Thinking Skills</li> <li> Creativity</li> <li> Personal-social Competence</li> </ul>

## Foreword / Background

'Percentage - Discount' is a topic already covered in the primary school curriculum. However, how well students can understand this topic covers a wide range. Some students might master the concept of percentage thoroughly while some may only know how to apply the formula to solve a simple problem without really understanding the Mathematics behind it. The project school uses English as the medium of teaching for Mathematics. Most students had not previously learnt the English vocabulary and phrases related to discount and discount percentage, so, usually, teachers needed to spend time introducing these English words and phrases. Routine textbook examples and practice exercises were then given to familiarize students with problems presented in English. For students who had already mastered the related Mathematical knowledge in primary school, they might not find it interesting and challenging enough to simply learn the same things in a different language.

The project school encourages collaborative learning in the classroom. In S1, students were seated in mixed-ability groups of 4 students in most lessons. Each group involved one high ability learner while the rest had medium or lower ability. Also, each group had a mini-blackboard so they could write down results of group discussion and show it to the class easily. Routines based on group work and the use of mini-blackboards were well-developed in the target classes. During discussion with Project GIFT, the teacher reflected that students were active in discussions and in answering teacher's questions. They were also keen on spotting others' mistakes and correcting them.

## Objectives of Collaboration

One key concern of the math lesson is that all students are expected to become familiar with the English words and phrases related to discount. Moreover, all students are expected to develop a deeper understanding of percentage rather than simply knowing how to apply the formula without understanding it. Teachers and the Project GIFT team agreed that discount percentage is a topic that is closely related to students' daily life, hence, teachers would like to relate this topic more to students' everyday experience. With such a design, students could be more engaged in the learning activities. Furthermore, tasks that help nurture higher-order thinking skills and creativity could be designed to stretch the potential of the students, especially the high-ability learners. To utilize the well-established classroom routines and students' learning habits mentioned in the foreword, the teacher requested to retain the usual practice of collaborative learning and the use of mini-blackboards when designing the lesson and wanted to provide a chance for students to evaluate classmates' solutions. In such a collaborative classroom, students are expected to develop their personal-social competence. Therefore, the objectives of the collaboration between the Project GIFT team and the school was to design a lesson not only to help all students learn the terms and phrases about discount percentage in English, but also to promote in-depth exploration about discount percentage in a collaborative classroom.

## Theoretical Framework

To promote in-depth exploration and understanding, higher-order thinking should be the essential element for designing this lesson. According to the Revised Bloom's Taxonomy (Anderson & Krathwohl, 2001), higher-order thinking refers to the cognitive processes 'apply', 'analyze', 'evaluate' and 'create'.

When designing the lesson, learning activities that aim to help students remember and understand the basic concepts were compacted into a short beginning part of the lesson. Much learning time was dedicated to learning tasks that encourage students to apply knowledge to solve more complicated problems and to analyze the consequences when some values are changed in the calculation. In these learning tasks, students were also given the chance to evaluate the solutions of their classmates. Last but not least, students were asked to create different ways to express discount. With more focus placed on cognitive processes related to higher-order thinking, students were expected to develop deeper understanding and refine their thinking skills.

Tinzmann et al. (1990) observed that knowledge and authority are shared among teachers and students in a collaborative learning environment. To establish collaborative learning, teachers encourage students to bring their knowledge and strategies to the learning situation. They help students listen to diverse opinions, support knowledge claims with evidence, engage in critical and creative thinking, and participate in open and meaningful dialogue. Also, teachers adjust the level of support so students take responsibility for learning.

Collaborative learning is more than having students seated and working in groups. The lesson should be student-centred and the teacher should act mainly as a facilitator of learning not as a deliverer of knowledge. Students should be given the chance to solve problems without clear direction given by teachers. They should also be given time to discuss among themselves in groups before asking for teacher's support. Moreover, it is also important for students to look at one another's ideas and strategies on the problem so they can learn from their classmates.

## Learning and Teaching Strategies

Pre-assessment by means of a worksheet was done before the lesson to check whether students had managed to handle the basic problems. If students had good mastery of basic knowledge, teachers could then focus on any common misunderstandings of students rather than re-teach contents students had already mastered.

To relate the lesson to students' everyday experience, students were asked to collect newspaper articles on or take photos of discount. Teachers explained concepts and keywords about discount percentage based on students' collections rather than just on textbook passages. Teachers also used some photos in the fund-raising activity at the school to draw students' attention. In daily life, students might see discount offered in ways that are more complicated than the textbook problems. More complicated problems about discount percentage were set to better relate subject contents

to daily life. Moreover, some questions that required students to consider change of quantity were added (Lesson Worksheet 1 Task 2). These questions require higher-order thinking skills. A divergent question (Lesson Worksheet 2) was set to help nurture students' creativity and at the same time check students' understanding. These tasks and questions were expected to help the whole class study the topic from different angles and hence provide more room for exploration and discussion among students.

To retain the usual practice of collaborative learning in the school, heterogeneous grouping was used as described in the foreword. In the lesson, students solved problems together and learnt from one another in a group setting. Mini-blackboards were used after each group task to allow students to present their ideas in words and symbols. If time allowed, some students were also chosen to present verbally to the whole class. In the lesson, most results were built and concluded by the students. Hence, they were expected to have gained a deep understanding of the topics.

## Discussion

Lesson trials were done in two classes. According to observation by the Project GIFT team and school teachers, students participated actively in discussion in all of the learning tasks. In some groups, students wrote down wrong answers in the beginning but finally corrected them after some group discussion. It showed that the level of difficulty was suitably set for the target classes so students really thought deeply. Teachers who joined the lesson observation thought that students learnt more than they did in ordinary Mathematics lessons in this newly designed lesson. Teachers who conducted the lesson were surprised that some weaker students could complete Task 1 and even got the answer in Task 2. However, there was not enough time for the creative exercise in both classes. One class only had 5 minutes for this part and another class could only leave this part as a post-lesson exercise.

In the lesson, heterogeneous grouping was chosen as this was the usual practice of the project school. When conducting this lesson in other schools, students may not have the same grouping routine. Hence, teachers should decide what kinds of groupings are suitable based on students and school background and needs. For example, if teachers want the higher-ability students to move faster and learn extensively and want to provide more support to the weaker students, teacher may use ability groupings instead. In that case, teacher should adjust the level of difficulty to cater for different ability groups. For example, extra hint cards can be prepared for weaker groups while some guiding elements like the table in Task 1 can be removed for groups with higher ability.

During the post-lesson observation, some teachers and Project team members also expressed concern about those students demonstrating high Mathematical ability. Even though the lesson included mainly tasks requiring higher-order thinking skills, these students might work faster than the others and might need further challenges. Hence, an extra question was later designed (already added into the Powerpoint and worksheet). This question asked students whether the discount percentage can be found without a given marked price. The question helps extend

students' knowledge from numerical calculation to algebraic manipulation and is suitable for students who move faster in the lesson.

In the lesson, students worked mainly in group settings. Teachers had worries about whether all the students could work out the problem independently. Therefore, independent tasks could be given after the lesson so as to make sure all students could follow. Also, it is important for students to formally write down their working steps when learning Mathematics.

To conclude, one key reason for the success of this lesson design is that the level of difficulty was well set – complicated enough to promote higher-order thinking while still within students' ability level. When the level of difficulty is suitably set, students' learning can be maximized. Therefore, it is important for teachers to understand what students can master and what really urges them to think deeply when designing a lesson.







# Lesson Plan




## Lesson 1

### Pre-lesson Task

Students collect pictures related to discount and stick them on the Pre-lesson Worksheet, and calculate a few questions about discount. Teacher collects the worksheets before the lesson to pre-access students' readiness and preliminary knowledge.

### Procedure

Learning Focus (Time)	Activity / Content	Learning & Teaching Strategies	Elements of GE	Learning & Teaching Resources
<b>Feedback on the pre-lesson task (10 minutes)</b>	<ol style="list-style-type: none"> <li>1. Teacher shows some pictures collected by students and some common mistakes.</li> <li>2. Teacher familiarizes students with the keywords: 'marked price', 'selling price', 'discount' and 'discount percentages'.</li> <li>3. Teacher checks the students' understanding on how to calculate discount and discount percentage.</li> </ol>			Pre-lesson Worksheet
<b>Different types of discount (15 minutes)</b>	<ol style="list-style-type: none"> <li>1. Students work in group to analyse the five types of discounts presented.</li> <li>2. Students use mini-blackboard to present their answers and check the mistakes of other group.</li> </ol>	Mixed-ability Grouping	 	Lesson Worksheet 1 (Task 1)
<b>Changes of discount (10 minutes)</b>	<ol style="list-style-type: none"> <li>1. Teacher first asks students to guess if there will be any change in discount percentage when the quantity of products changes.</li> <li>2. Students work in group to discuss the answers and finish Lesson Worksheet 1 (Faster groups can have discussion on the extra question on the worksheet).</li> </ol>	Mixed-ability Grouping	 	Lesson Worksheet 1 (Task 2)

Learning Focus (Time)	Activity / Content	Learning & Teaching Strategies	Elements of GE	Learning & Teaching Resources
<b>Creative Exercise (15 minutes)</b>	Students work in group to suggest different ways to present the required discount according to the instructions on Lesson Worksheet 2.	Mixed-ability Grouping	 	Lesson Worksheet 2
<b>Summary and Extension (10 minutes)</b>	Teacher gives a summary and asks students to explore more on the topic.	Mixed-ability Grouping		Lesson Worksheet 2

### Extended Learning Activity

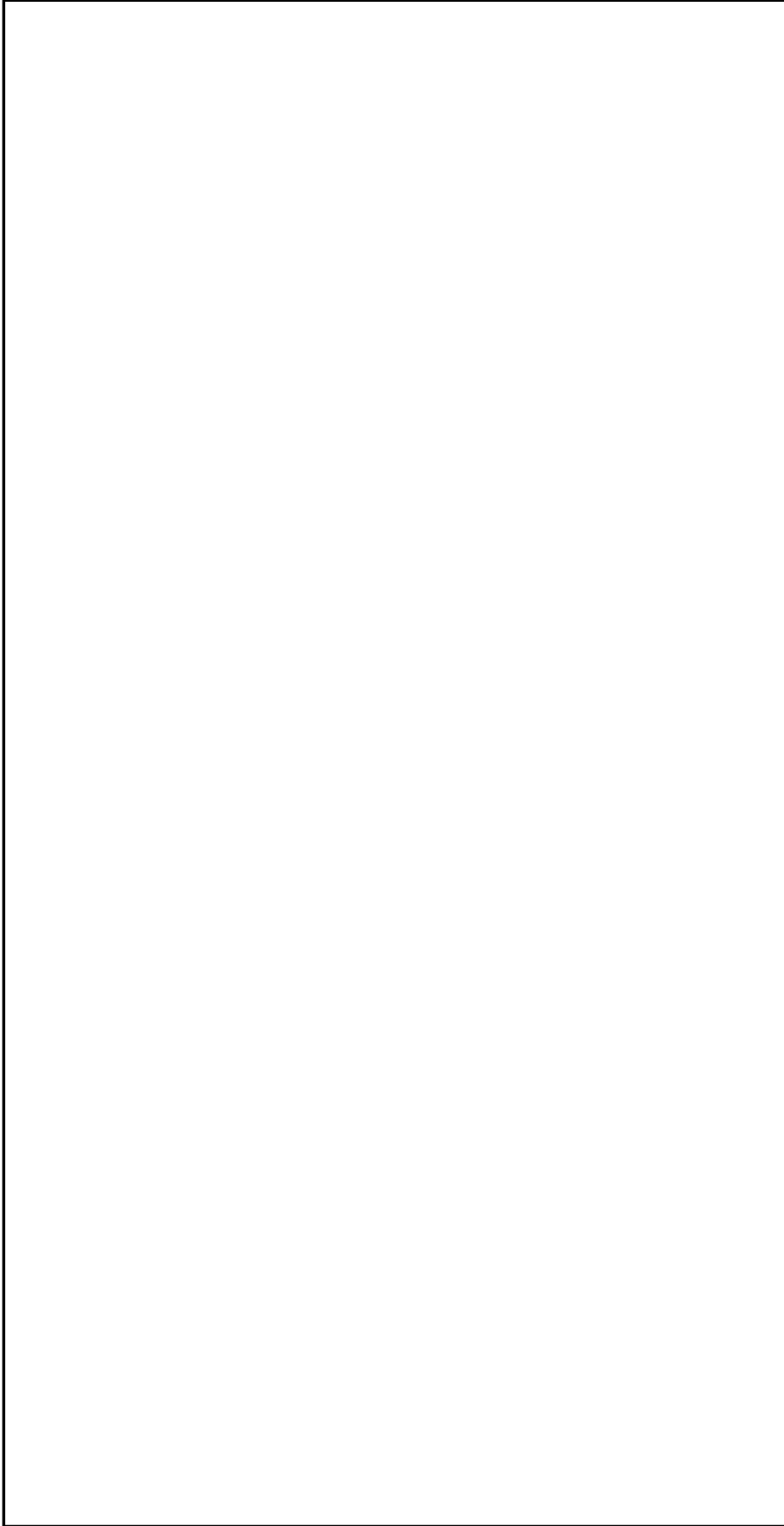
Students find out whether the discount percentage can be found when the price is not given in different cases, and finish the extra question in Lesson Worksheet 1.

# Lessons 1 -2

## Pre-Lesson Worksheet

### S1 MATHEMATICS Discount





**Task 1** There are different kinds of discounts in our daily life. Please collect pictures related to discount and stick them below.



# Lessons 1 -2

## Pre-Lesson Worksheet

**Task 2** Please answer the following questions.

Scenario 1		Scenario 2		
	<div style="border: 1px solid black; padding: 5px; text-align: center;"> <b>\$10 / Piece</b>  <b>20% off</b> </div>		<div style="border: 1px solid black; padding: 5px; text-align: center;"> <b>\$20/Piece</b>  <b>\$16/Piece</b> </div>	
[Buy 1 piece]	Marked Price	Selling Price	Discount	Discount %
Scenario 1				
Scenario 2				
Scenario 3		Scenario 4		
	<div style="border: 1px solid black; padding: 5px; text-align: center;"> <b>\$24/Piece</b>  <b>\$36/2 Pieces</b> </div>		<div style="border: 1px solid black; padding: 5px; text-align: center;"> <b>\$26/Piece</b>  <b>Buy 1 get 1 free</b> </div>	
[Buy 2 pieces]	Marked Price	Selling Price	Discount	Discount %
Scenario 3				
Scenario 4				

# Lessons 1 -2

## Lesson Worksheet 1

### S1 MATHEMATICS

#### Discount

#### TASK 1

Christy needs to buy **36 cartons** of lemon tea. A 6-carton pack costs \$20. There are five kinds of special discount. Here are the examples:

**Discount A:**

Buy 2 packs  
(6-carton pack)

**Discount B:**

Buy the 2nd pack  
(6-carton pack)  
at half price

A 6-carton pack of lemon tea : \$20

Please complete the following table using information in the scenario above.

	Marked Price (36 cartons)	Selling Price (36 cartons)	Discount	Discount %
<b>Discount A</b> <u>Buy 2 get 1 free</u>				
<b>Discount B</b> <u>Buy the 2<sup>nd</sup> at half price</u>				
<b>Discount C</b> <u>All packs 20% off and then extra 10% off</u>				
<b>Discount D</b> <u>Buy 1 pack then pay \$5 to get one more pack</u>				
<b>Discount E</b> <u>Purchase \$100 above can get a \$24 cash coupon</u>				



# Lessons 1 -2

## Lesson Worksheet 1

### TASK 2

Christy needs to buy 18 cartons of lemon tea.

	Marked Price (18 cartons)	Selling Price (18 cartons)	Discount	Discount %
<b>Discount A</b> <u>Buy 2 get 1 free</u>				
<b>Discount B</b> <u>Buy the 2<sup>nd</sup> at half price</u>				

Q2.1 Compare to Task 1 Discounts A and B , does the discount percentage change when Christy buys 18 cartons instead of 36 cartons ?

Q2.2 Without calculation, can you guess, for Discounts C , D and E , will the discount percentage change when Christy buys 18 cartons instead of 36 cartons ? Explain your guess.

### EXTRA QUESTION

If the marked price of the product is unknown, can we still find out the discount percentage for Discounts A, B, C, D and E ?

<b>Discount A</b> Buy 2 get 1 free
<b>Discount B</b> Buy the 2 <sup>nd</sup> at half price
<b>Discount C</b> All packs 20% off and then extra 10% off
<b>Discount D</b> Buy 1 pack then pay \$5 to get one more pack
<b>Discount E</b> Purchase \$100 above to get a \$24 cash coupon

Buy **36** cartons(盒) of lemon tea.  
A 6-carton pack (6 盒裝) of  
lemon tea : \$???

# Lessons 1 -2

## Lesson Worksheet 2

### S1 MATHEMATICS

#### Discount

Creative Exercise:

You are the shop owner of ABC City. Your shop sells many daily goods and each item is \$10 . You want to **make a 20 % discount off** to the customers when they **buy any 5 items**. Discuss with your groupmates and suggest different ways to offer the required discount.

Types of discount	Marked price (5 items)	Selling price (5 items)	Discount (self-checking)	Discount % (self-checking)
E.g. All items 20% off	$10 \times 5 = \$50$	$50 \times 80\% = \$40$	$50 - 40 = \$10$	$\frac{50 - 40}{50} \times 100\% = 20\%$
1.				
2.				
3.				
4.				
5.				
6.				
7.				
8.				
9.				
10.				

# Lessons 1 -2

## Suggested Answers

### Suggested Answers:

#### Pre-lesson Worksheet Task 2

[Buy 1 piece]	Marked Price	Selling Price	Discount	Discount %
Scenario 1	\$10	\$8	\$2	20%
Scenario 2	\$20	\$16	\$4	20%

[Buy 2 pieces]	Marked Price	Selling Price	Discount	Discount %
Scenario 3	\$48	\$36	\$12	25%
Scenario 4	\$52	\$26	\$26	50%

#### Lesson Worksheet Task 1

	Marked Price (\$)	Selling price(\$)	Discount(\$)	Discount %
Discount A	120	80	40	$33\frac{1}{3}$ %
Discount B	120	90	30	25%
Discount C	120	86.4	33.6	28%
Discount D	120	75	45	37.5%
Discount E	120	96	24	20%




#### Lesson Worksheet Task 2

	Marked Price (18 cartons)	Selling Price (18 cartons)	Discount	Discount %
<b>Discount A</b> Buy 2 get 1 free	60	40	20	$33\frac{1}{3}$ %
<b>Discount B</b> Buy the 2 <sup>nd</sup> at half price	60	50	10	$16\frac{2}{3}$ %

# Proofs of Pythagoras' Theorem

**Grade: Secondary 2**

**No. of Lessons (Learning Time): 2 Consecutive Lessons (80 minutes)**

<p><b>Prior Knowledge</b></p>	<ul style="list-style-type: none"> <li>- Square Number and Square Root</li> <li>- Congruent and Similar Figures</li> <li>- Angle Relations about Straight Lines and Triangles</li> <li>- Algebraic Identities about Squares</li> </ul>
<p><b>Learning Objectives</b></p>	<ul style="list-style-type: none"> <li>- Students should be able to understand a few proofs of Pythagoras' Theorem</li> <li>- Students present the proofs of Pythagoras' Theorem</li> <li>- Students can apply Pythagoras Theorem to find unknown sides in a right-angled triangle</li> <li>- Students develop positive attitudes towards Mathematical proofs</li> </ul>
<p><b>Intended Learning Outcomes</b></p>	<ul style="list-style-type: none"> <li>- Students present Mathematical knowledge logically, fluently and systematically</li> <li>- Students follow the presentation attentively</li> <li>- Students solve complex tasks with various problem solving skills</li> <li>- Students demonstrate effective communication and collaboration skills</li> <li>- Students enjoy the process of exploring and sharing Mathematical knowledge</li> </ul>
<p><b>Learning &amp; Teaching Strategies</b></p>	<p>Student-led Activity, Flexible Grouping, Tiered Assignment, E-learning</p>
<p><b>Operation Mode of Gifted Education</b></p>	<p>Level 1: School-based Whole-class Teaching</p>
<p><b>Core Elements of Gifted Education</b></p>	<ul style="list-style-type: none"> <li> Higher-order Thinking Skills</li> <li> Creativity</li> <li> Personal-social Competence</li> </ul>

## Foreword / Background

More often than not, rigorous Mathematical proofs are presented with a focus on logical reasoning and manipulative skills. This type of presentation may only appeal to students with a strong interest in Mathematics but not all students. Also, the proofs are usually delivered through a teacher-centred approach – the teacher describes the steps and students try to follow and understand the proof. However students who have yet to develop their interest and skills in math may not be fully engaged in the learning process, not to mention actually enjoying it. Moreover, given this approach, students with high Mathematical ability cannot stretch their potential by constructing the proofs by themselves.

The target group of this lesson was a class of about 30 students with mixed Mathematical ability. In terms of ability and prior knowledge in Mathematics, over half of them were of medium level while there were about 5 to 8 high-achievers and 3 to 5 low-achievers. In the past, the learning content were usually designed based on the medium-level students and the low-achievers as they were the majority of the class and needed more support from teachers.

Students had diverse interests and learning styles. About one-third of the students were talkative and liked to share ideas with others. The high-achievers loved to challenge themselves by solving complex problems. The low-achievers were less confident in learning Mathematics and needed step-by-step demonstrations when learning new formulae. Some students were visual learners and could learn better with the help of simulations or figures. The teacher found it difficult to cater for the diverse learning needs of the students.

## Objectives of Collaboration

The aim of the collaboration was to design a student-centred lesson around the proofs of Pythagoras' Theorem based on students' potential and characteristics. Teachers rethought how to help students learn the proofs and hoped that students could enjoy learning Mathematical proofs and appreciate the wisdom behind the proofs. They also wanted to engage students with high Mathematical ability and those talkative students, make use of their strengths and help them stretch their potential.

## Theoretical Framework

One of the key tasks of gifted education is to attend to the diverse potential and characteristics of individual students with a view to guiding and supporting them to develop their giftedness into flourishing talents (Education Bureau, n.d.).

According to the Theory of Multiple Intelligences (Gardner, 1983), there are eight intelligences embedded in the human mind, namely linguistic, logical, spatial, musical, bodily kinesthetic, intrapersonal, interpersonal, and spiritual, moral and existential intelligence intelligences. In the class, some students had high linguistic and interpersonal intelligences. These students had good presentation and communication skills. They liked to express their ideas verbally and work with



others. There were also students with high visual/spatial potentials. They were interested in figures, simulations or origami. These students might not be high achievers in Mathematics. If the learning activities were designed to address their strengths and interests, they could be more engaged in the lesson.

To enhance the quality of education, three core elements of gifted education, namely higher-order thinking skills, personal-social competence and creativity, can be integrated into regular lessons. Constructing a Mathematical proof of a new theorem can help promote students' higher-order thinking skills as students need to relate the new theorem to their prior knowledge, the figures and simulations given and the guidelines provided by the teacher. It is a complex task which requires higher-order thinking skills such as reasoning and problem-solving skills. Students' personal-social competence could be developed through group activities and presentations. Suitable grouping provides students with a chance to work collaboratively and learn from peers. To prepare a presentation about Mathematics, students need to tidy up and organize abstract ideas. Through the process of formulating solutions, presenting ideas in their own ways and suggesting ways of improving their solutions, students' creativity can be developed and strengthened (Education Bureau, 2017).

In the Level 1 implementation of gifted education, differentiated teaching through appropriate grouping of students can be adopted to meet the variant needs of the groups resulting in enrichment and extension of the curriculum across all subjects in regular classrooms (Education Bureau, n.d.). In a differentiated classroom, learning activities, materials and products can be adjusted appropriately so that students with various needs can be appropriately challenged. The adjustments can be from foundational to transformational, concrete to abstract, simple to complex, single facet to multiple facet, small leap to great leap, structured to open-ended, dependent to independent or slow to fast (Tomlinson, 2005).

Teachers can adopt differentiation based on students' strengths, interests and learner styles. Learning materials can be adjusted and assigned according to students' Mathematical ability so that they are appropriately challenged. Students with high Mathematical ability can comprehend and remember Mathematics knowledge quickly. It is not challenging enough for them to just understand a theorem and solve routine problems in the textbook. Complex problems that involve higher-order thinking skills are suitable for them. For weaker students, more scaffolding can be provided so that they can accomplish the same learning objectives. For students who like to talk and share or those having good leaderships skills, learning tasks involving personal-social competence like group work or presentation can suit their interests and learner styles. Through differentiation, the teacher can utilize students' potential and create a chance for success for all students.

## Learning and Teaching Strategies

One key learning objective of the lesson was that all students were expected to have a basic understanding of the Pythagoras' Theorem. Some basic components of a Mathematics lesson like demonstrating examples and practicing textbook questions were involved to help students master basic knowledge and skills. These components were essential for the less-able students when learning a new theorem.

The lesson also aimed to engage students with different learning needs in learning Mathematics and help them develop positive attitudes towards Mathematical proofs. To achieve these objectives, a student-led activity and two group activities with different ways of grouping and learning focus were designed.

### 1. Student-led activity

Seeing the high linguistic potential of some students, a student-led activity was designed. Two to three students with good presentation and interpersonal skills were chosen as student leaders. They were responsible for leading an origami activity that demonstrated a proof of Pythagoras' Theorem. Prior to the lesson, teachers introduced the origami activity to those students and asked them to prepare an interactive presentation. In the lesson, they were expected to state the Theorem accurately, lead the class with clear instructions, write down the algebraic steps correctly and raise questions to the whole class. These student leaders would have the chance to stretch their potential in linguistic, spatial, bodily-kinesthetic and interpersonal domains.

### 2. Group Activity 1 [Proof Exploration] : Homogeneous Grouping

To cater for learners with different levels of Mathematical ability, students were divided into eight groups: 2 high-ability groups, 4 medium-ability groups and 2 groups mixing some medium-ability and some low-ability students. Eight sets of worksheets with different levels of complexity were assigned to the groups accordingly. In each group, students viewed GeoGebra material about a proof of the theorem and had to fill in the details of the proof.

For the high-ability groups, students needed to apply cross-topic knowledge and higher-order thinking skills to finish the tasks. Some of the tasks also involved theorems they had never learnt before. For the other groups, the worksheets were simpler or had more guidelines. Since high-ability groups were provided with more challenging tasks, they might spend time struggling or might ask for hints from teachers. For the other groups, as more guidelines were provided in the worksheets, students were expected to finish the tasks without help from teachers. Simpler proofs about Pythagoras' Theorem were assigned to the groups with mixed medium-ability and low-ability students. Low-ability students could receive help from the medium-ability students in the group. The above grouping design allowed teachers to spend more time with the high-ability groups and facilitate further discussion among them. After the activity, it was expected all students would have in-depth understanding of the proof assigned to them, which is one major learning objective of the lesson.

### 3. Group Activity 2 [Proof Presentation] : Heterogeneous Grouping

After exploring a proof, presentation and sharing tasks were then carried out using a mixed ability grouping. Students were grouped with classmates having different sets of worksheets. In the groups, students took turns to explain the proof they had worked with. Teachers walked around or sat in some groups to listen to the presentation and comment on their presentation skills. Some students could also be chosen to present to the whole class. In this activity, all students, even the students less able in Mathematics, were expected to share their findings with confidence and appreciate others' work. Talkative students might find this activity enjoyable. Through exchanging knowledge, students could broaden their horizons on the topic. As such, their personal-social competence could be enhanced.

A flexible grouping strategy was adopted in this lesson by having two group activities with different learning foci and grouping nature. According to Tomlinson (2005), a flexible grouping strategy allows students to work both with students most like themselves and with students dissimilar from themselves. When a learning task is designed, teachers could assign work groups based on students' characteristics and the objective of the tasks. The proof-exploration task aims to allow students to study a proof that matches their Mathematical ability. Therefore, groups with similar ability are more suitable. The proof-presentation task encourages students to exchange knowledge and nurtures students' presentation skills. Hence, heterogeneous grouping is more appropriate.

Appropriate assignments can allow students to explore ideas at a level that builds on their prior knowledge and prompts continued growth. Tiered assignments were designed for this lesson. Teachers can design tiered assignments by adjusting the task for complexity, abstractness, number of steps, concreteness and independence (Tomlinson, 2005). This strategy allows students to work with appropriately challenging tasks and promotes motivation.

Proofs of Pythagoras' Theorem are closely related to figures and diagrams. During the lesson, visual tools like computer simulations and hand-on activities like paper-cutting were involved in the lesson to suit the visual learners.

Given that student-centred learning activities addressed students' different potentials, interest and learning styles, students were expected to be more engaged in the lesson and develop a positive attitude towards Mathematical proofs. With the lesson materials differentiated by their learning needs, students of all levels can master the basic knowledge and also be appropriately challenged. Thus, the lesson could provide a chance for success for all students in the class, not only those with high Mathematical ability.

### Discussion

The Project GIFT team and teachers who conducted the lesson observed that students were engaged in and committed to the learning process. Student leaders had high initiatives doing the preparation before the lesson. They demonstrated effective communication skills. They also had

bright smiles during the presentation, which implied that they enjoyed their roles as presenters. This also showed that the lesson helped to establish students' personal-social competence. Their classmates followed their instructions and actively answered the questions posed by them. So students obtained a strong sense of satisfaction in this learning process while their personal-social competence was enormously enhanced. Moreover, students with high Mathematical ability benefitted from the more challenging tasks and the homogenous groupings. These groups of students received the most challenging worksheets. They could not figure out the answer at once, so they did not finish the task faster than the others and be left idle. Instead, they spent time discussing, looking for hints and finally solved the problem. Even the students weaker in Mathematics enjoyed the lesson. They did not find it embarrassing to receive an easier worksheet. Instead, they could finish with only a little help from teacher and they cherished the opportunities to present the proofs that other classmates had not yet studied. This appropriate level of the learning task leads to the development of students' high-order thinking. In the proof presentation activity, most students could present the Mathematics knowledge correctly. Some of them presented with fluent language and strong confidence.

Teachers who conducted the lesson found that they needed much time to prepare before the lesson. They needed to help student presenters to prepare and rehearse for the student-led activity. It also took much time for teachers to think about the hints and questions for eight different worksheets. However, teachers found these extra efforts worthwhile when they saw that even the students who were not interested in Mathematics in the past participated actively in the lesson.

To prepare for the student-led activity, teacher can choose two to three students with high linguistic and interpersonal potentials (need not be the high achievers in Mathematics) as the student leaders. Teacher are advised to meet these leaders a few times to clarify their understanding of the topic, to rehearse the student-led activity and to polish their presentation skills.

Before conducting the lesson, teachers are advised to arrange the first grouping based mainly on students' Mathematical abilities. Other characteristics of students should also be considered. For example, teachers may arrange the groups so that each group contains a student with good leadership skills. Or teachers may need to take care of the needs of SEN students when arranging the groups.

Teachers can adjust the level of challenge by revising the guidelines in the worksheets or selectively adapting some of the worksheets provided. It may be easier for teachers to handle if only four worksheets are chosen to be used. Each group could be given two worksheets with less challenging questions and followed by another two worksheets which are more challenging. Teachers can select the worksheets based on the Mathematical ability of the class. For example, teachers can select the more difficult worksheets if the class involves more students with high Mathematical ability.

In the lesson, teachers can mainly act as facilitators by providing hints and feedback to the groups.

Teachers can also summarize the learning focus and check students' understanding after each section of the lesson. It may be difficult to support all eight groups during the lesson. The teacher may prepare hint cards so students can read the hints by themselves. Alternatively, the school may arrange more than one teacher to prepare for and co-teach this lesson. To nurture collaboration skills, teachers can also add some reflection elements into the group activities. For example, they may ask students to comment on one another's performance in the group or may ask students to rate their own contribution to the group.

To conclude, this lesson illustrated some rationale and strategies to design a lesson that can make use of students' strengths, cater for diverse learning needs and stretch the potential of students with high ability. Teachers can also make use of these strategies to design lesson with topics other than proofs of Pythagoras' Theorem.





# Lesson Plan

## Lesson 1


### Pre-lesson Tasks

1. Teacher chooses two to three students with good presentation skills as student presenters. They are given some resources about the proof to prepare for the presentation. Teachers can offer help to the group and rehearse with them if necessary.
2. Students are arranged into groups of 3 to 4 students with similar Mathematical ability by teachers . Students can be seated according to this grouping at the beginning of the lesson.

### Procedure

Learning Focus (Time)	Activity / Content	Learning & Teaching Strategies	Elements of GE	Learning & Teaching Resources
<b>Introduction (5 minutes)</b>	Teacher shows a piece of paper with the corners removed and asks students to think of a way to get a right angle using the piece of paper. Students may fold it and justify by using the angle relations on straight lines.			A paper with the corners removed
<b>Student-led Activity (15 minutes)</b>	<ol style="list-style-type: none"> <li>1. Pre-chosen student presenters introduce the Pythagoras' Theorem. They demonstrate and guide the whole class to study a proof of the theorem by paper cutting and folding.</li> <li>2. Other students follow the paper cutting and folding, and answer the questions raised by the presenters.</li> </ol>	Student-led Activity	 	A rectangular paper and a pair of scissors for each student
<b>Examples and practice (15 minutes)</b>	<ol style="list-style-type: none"> <li>1. Teacher leads the whole class to summarize the Pythagoras' Theorem and shows how to use it to find the unknown side in a right-angled triangle.</li> <li>2. Students are then given time to do relevant textbook practice.</li> </ol>		 	



Learning Focus (Time)	Activity / Content	Learning & Teaching Strategies	Elements of GE	Learning & Teaching Resources
<b>Proof Exploration Activity (15 minutes)</b>	<ol style="list-style-type: none"> <li>Students are arranged into groups with similar Mathematical ability. Each group use the tablets to view the GeoGebra materials. Worksheets are chosen according to the group's ability.</li> <li>Students view the GeoGebra which demonstrates a proof of Pythagoras' Theorem. They work out the details of the proof with the guidelines on the worksheets. Afterwards, they prepare a short presentation of the proof.</li> </ol>	Ability Grouping E-Learning Tiered Assignment		Tablets GeoGebra materials Lesson Worksheets (8 sets)
<b>Proof Presentation (15 minutes)</b>	<ol style="list-style-type: none"> <li>Students are rearranged into group of mixed ability. Each student is provided with all other sets of worksheets and moves to a new seat.</li> <li>In each group, students take turns to present the proof they studied in the previous activity. During the presentation, students may raise questions or fill in the worksheets.</li> <li>Teacher walks through the classroom or sit in some groups to provide feedback to students' presentation. If time is allowed, teacher can choose a student to present to the whole class.</li> </ol>	Mixed Ability Grouping		Tablets GeoGebra materials Lesson Worksheets (8 sets)
<b>Summary (5 minutes)</b>	Teacher conveys the message that a theorem can be proved in many ways and Mathematicians are always looking for a better solution. Teacher further introduces the contribution of Chinese Mathematicians related to Pythagoras' Theorem.			

### Extended Learning Activities

1. Teacher can assign textbook practices about the use of Pythagoras' Theorem.
2. For students who want to further explore, they can study the Extension Reading Materials and Worksheet – 中國數學家與畢氏定理, and the video 'How many ways are there to prove the Pythagorean theorem? - Betty Fei' . Teacher can also use the materials to tell them the contributions of Chinese mathematicians, who are less commonly known by students.
3. For students showing high Mathematical ability and strong interest in Mathematics, they can join the Level 2 Gifted Education Programme "Extension of Pythagoras' Theorem", which provided enrichment and extension knowledge related to the theorem such as Pythagorean Triple and Fermat's Last Theorem. It includes tasks that can train students' inquiry and Mathematical thinking skills.

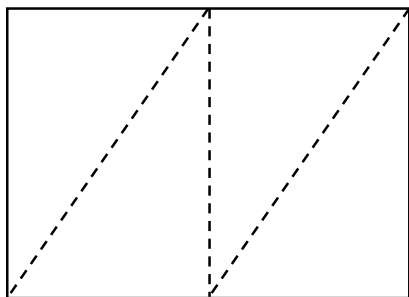
## Lessons 1 -2

### Resources for Student Presenters

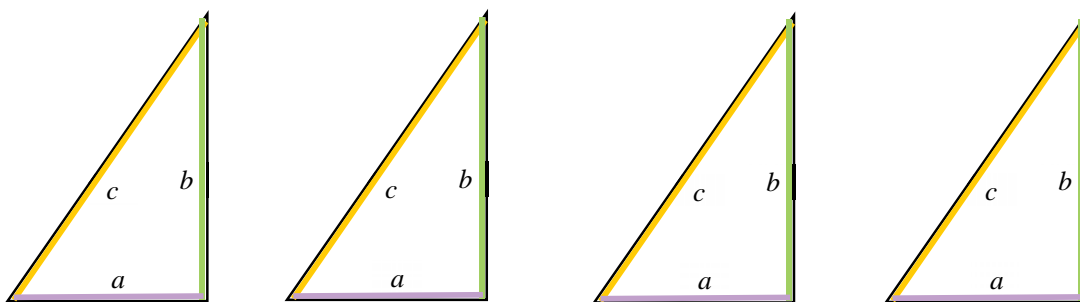
#### A proof of Pythagoras' Theorem by paper folding and cutting

Each student is provided with a rectangular paper. The papers of different students can have different dimensions.

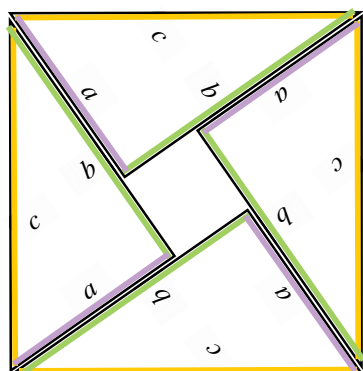
Step 1 : Fold along the dotted lines and cut the paper into four triangles.



Step 2 : Highlight the sides with different colors and name the sides of the triangles.



Step 3 : Rearrange the triangles so that the square is enclosed by the triangles.



Step 4 : Deduce the Pythagoras' Theorem by the area relations.

$$\text{Four Triangles} = 4 \times \frac{1}{2}ab = 2ab$$

$$\text{Large Square} : c^2$$

$$\text{Small Square} = (b-a)^2$$

Small Square + Four Triangles = Large Square

$$2ab + (b-a)^2 = c^2$$

$$2ab + b^2 - 2ab + a^2 = c^2$$

$$a^2 + b^2 = c^2$$

## Lessons 1 -2

### Lesson Worksheets (8 sets)

**Learning and Teaching Resources    Topic : Proofs of Pythagoras' Theorem**

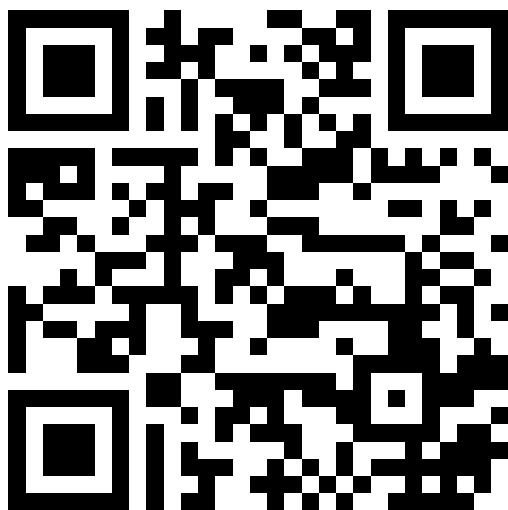
1. Group Work 1 [Proof Exploration] - GeoGebra and Worksheets

There are eight sets of materials. Each set includes a worksheet and a GeoGebra material (which can be placed online for easy access with iPad.)

The worksheet and the GeoGebra material guide study to explore a proof of Pythagoras' Theorem. Teacher can select some of the sets or make amendment according to students' ability.

GeoGebra Link: <https://www.geogebra.org/m/KVdpKX3N>

Set	Difficulty
1	Easy
2	Easy
3	Easy
4	Hard
5	Hard
6	Medium
7	Medium
8	Hard



Scan the QR code to go to the page

<https://www.geogebra.org/m/KVdpKX3N>

# Lessons 1 -2

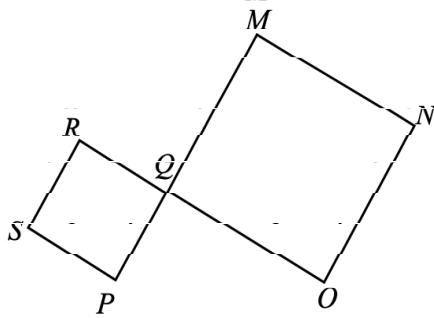
## Lesson Worksheets (8 sets)

Name: \_\_\_\_\_

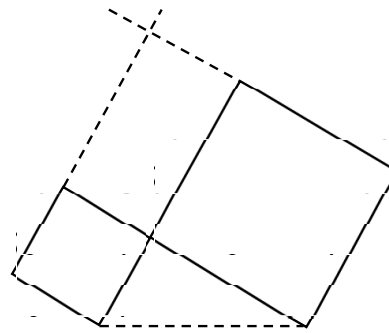
Class: \_\_\_\_\_ ( )

### Set 1 --- Proof by Rearrangement

[2 pages]

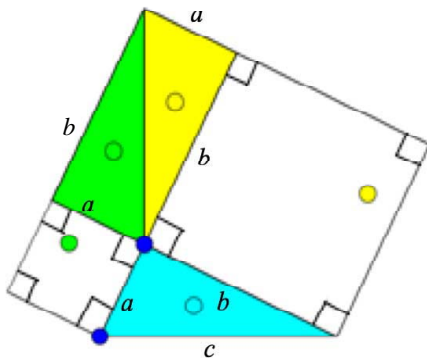


Two squares are put together with vertices  $P$ ,  $Q$  and  $M$  collinear.



Lines are extended from the edge of the square or joined from the vertices

Figure 1 is then formed by cutting the top rectangle into two triangles as shown.



- Q1. Is  $\angle PQO = 90^\circ$ ? Why?
- Q2. Are these three triangles congruent? Which reason (SSS, SAS, ASA, AAS, RHS) can explain the congruence?
- Q3. Express the area of the whole figure in terms of  $a$  and  $b$ . [Hint: Three triangles + Two Square]

## Lessons 1 -2

### Lesson Worksheets (8 sets)

Figure 1

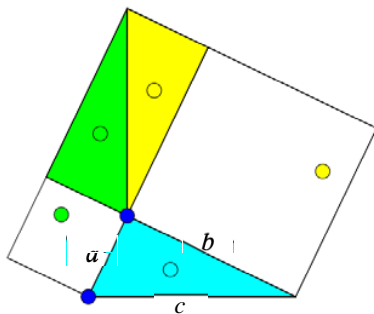
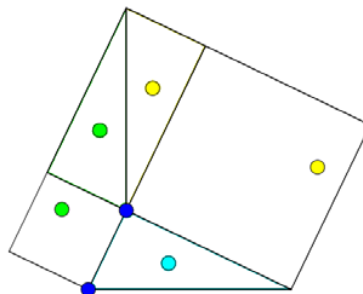


Figure 2



- Q4.** Following the Geogebra, triangles are moved to new positions. Draw lines in **Figure 2** to show it.
- Q5.** Express the area of the whole figure in terms of  $a$ ,  $b$  and  $c$ . [Hint: Three Triangles + One Square]
- Q6.** Prove the Pythagoras' Theorem ( $a^2 + b^2 = c^2$ ) using the areas in **Q3** and **Q5**.



# Lessons 1 -2

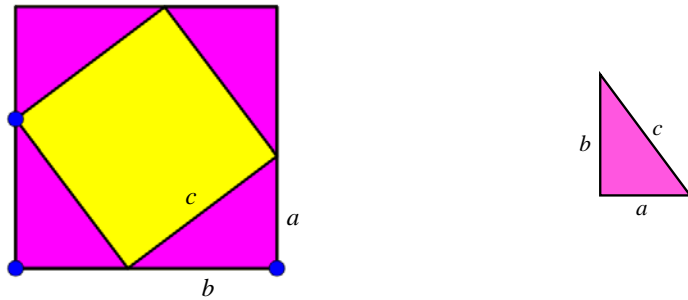
## Lesson Worksheets (8 sets)

Name: \_\_\_\_\_ Class: \_\_\_\_\_ ( )

### Set 2 --- Proof by Rearrangement

[1 page]

Figure 1

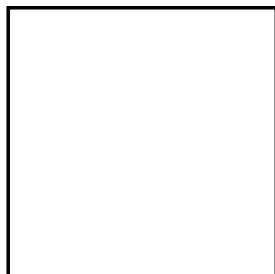


Q1. How is **Figure 1** formed?

It is formed by rearranging four c \_\_\_\_\_ triangles into a big s \_\_\_\_\_ .

Q2. What kind of quadrilateral is formed in the yellow part?

Figure 2 Follow the slider in the GeoGebra to draw the new figure obtained.



Q3. Two quadrilaterals are formed in the yellow part now. What kind of quadrilaterals are they?

Q4. Comparing the area of the yellow parts in **Figure 1** and **Figure 2**.

Can you prove the Pythagoras' Theorem ( $a^2 + b^2 = c^2$ ) ?

In **Figure 1**, the yellow part is a \_\_\_\_\_ , the area = \_\_\_\_\_

In **Figure 2**, the yellow parts are \_\_\_\_\_ , the total area = \_\_\_\_\_

Therefore, \_\_\_\_\_

# Lessons 1 -2

## Lesson Worksheets (8 sets)

Name: \_\_\_\_\_ Class: \_\_\_\_\_ ( )

### Set 3 --- Proof by Rearrangement

[1 page]

In the beginning, two squares are placed side by side in **Figure 1**.

When you follow the slider in the Geogebra, two white triangles are formed in **Figure 2**.

Figure 1

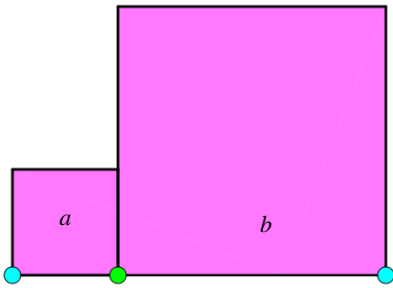
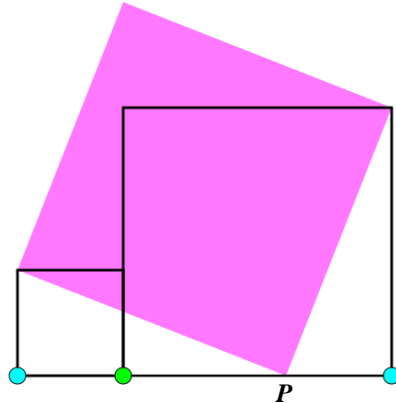
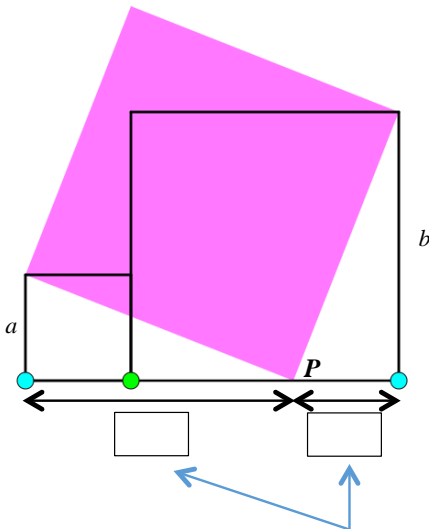


Figure 2



Move the green dot to change the size of the squares and observe the change in point  $P$ .

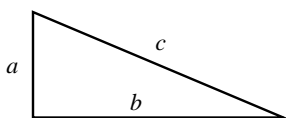
Figure 3



Question: Write down the length of these two line segments in terms of  $a$  and  $b$ .

Can you prove the Pythagoras' Theorem ( $a^2 + b^2 = c^2$ ) using **Figure 1** and **Figure 3**?

Let  $a$ ,  $b$  and  $c$  be the sides of the white triangles as shown.



In **Figure 1**, the purple parts are \_\_\_\_\_, the total area = \_\_\_\_\_

In **Figure 3**, the purple part is a \_\_\_\_\_, the area = \_\_\_\_\_

Therefore, \_\_\_\_\_

# Lessons 1 -2

## Lesson Worksheets (8 sets)

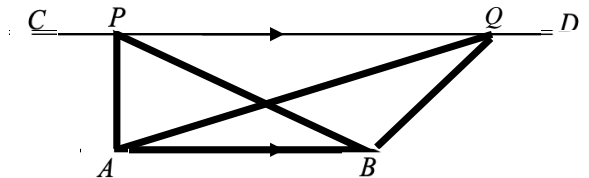
Name: \_\_\_\_\_ Class: \_\_\_\_\_ ( )

### Set 4 --- Proof by Area Relation

[2 pages]

**Observation:** Given two parallel line segments  $AB$  and  $CD$ .

Two triangles  $APB$  and  $AQB$  are drawn with  $AB$  as their common base.



What is the relation of the **Area** of  $\triangle APB$  and  $\triangle AQB$ ?

Hint: Two triangles have the same base  $AB$ , how about the heights?

Following the slider in the GeoGebra, Figures are obtained. Lengths  $a$ ,  $b$  and  $c$  are marked as shown.

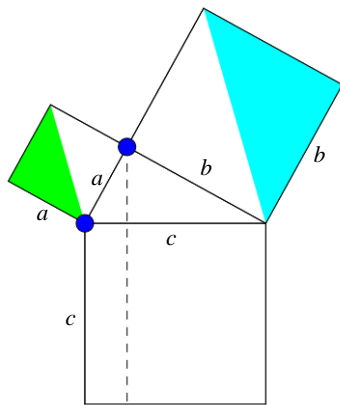


Figure 1

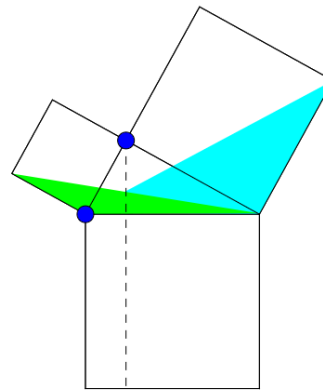
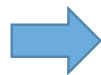


Figure 2

**Q1.** In **Figure 1**, find the area of the green triangle and blue triangles in terms of  $a$  and  $b$ .

Area of Green Triangle = \_\_\_\_\_

Area of Blue Triangle = \_\_\_\_\_

**Q2.** In **Figure 2**, find the area of the green triangle and blue triangles in terms of  $a$  and  $b$ .

(Hint: Use the **Observation**. How are the new triangles related to those in **Figure 1**?)

Area of Green Triangle = \_\_\_\_\_

Area of Blue Triangle = \_\_\_\_\_

# Lessons 1 -2

## Lesson Worksheets (8 sets)

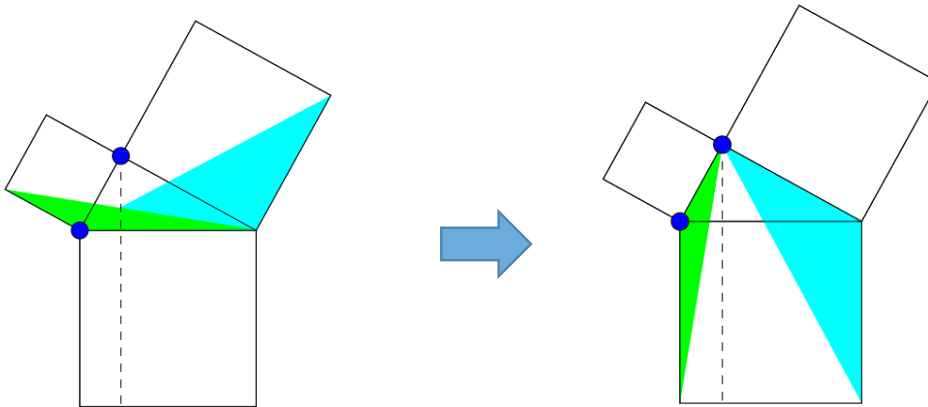


Figure 2

Figure 3

**Q3.** In **Figure 3**, the two triangles are transformed.  
 What kind of transformation is it? Will the area be changed after the transformation?

R \_\_\_\_\_. The area ( will / will not ) be changed.

Area of Green Triangle = \_\_\_\_\_

Area of Blue Triangle = \_\_\_\_\_

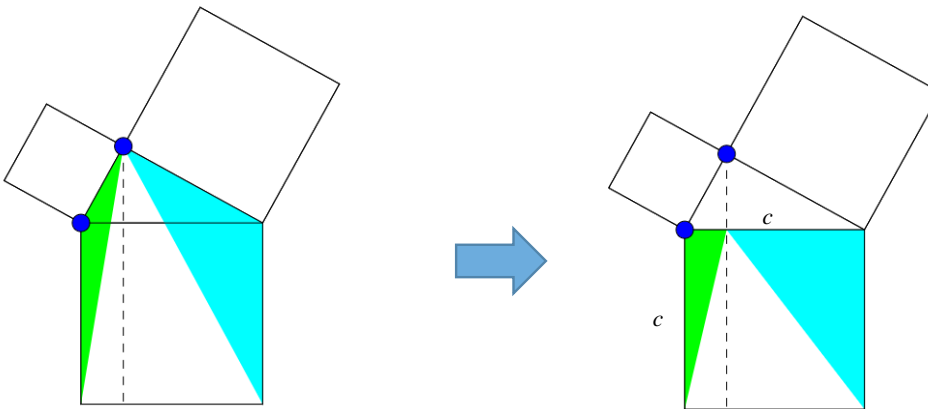


Figure 3

Figure 4

**Q4.** In **Figure 4**, find the area of the green triangle and blue triangle in terms of  $a$  and  $b$ .  
 (Hint: Use the **Observation**. How are the new triangles related to those in **Figure 3**?)

Area of Green Triangle = \_\_\_\_\_

Area of Blue Triangle = \_\_\_\_\_

**Q5.** In **Figure 4**, the two triangles are now inside the square with side  $c$ .  
 Find the sum of the two triangles in terms of  $c$ .

Area of Green Triangle + Area of Blue Triangle = \_\_\_\_\_

(Hint: What is the fraction of the area of two triangles compared to the square with side  $c$ .)

**Q6.** Can you prove the Pythagoras' Theorem ( $a^2 + b^2 = c^2$ ) using the area relation?

# Lessons 1 -2

## Lesson Worksheets (8 sets)

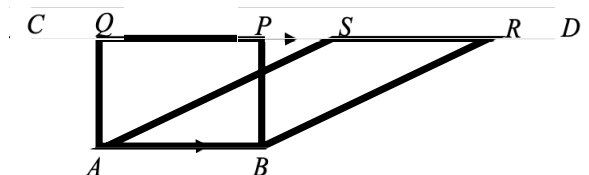
Name: \_\_\_\_\_ Class: \_\_\_\_\_ ( )

### Set 5 --- Proof by Area Relation

[2 pages]

**Observation:** Given two parallel line segments  $AB$  and  $CD$ .

A rectangle  $ABPQ$  and parallelogram  $ABRS$  are drawn with  $AB$  as their common base.



What is the relation of the **Area** of rectangle  $ABPQ$  and parallelogram  $ABRS$  ?

(Hint: They have the same base  $AB$ . How about the heights?)

Following the slider in the GeoGebra, Figures are obtained. Lengths  $a$ ,  $b$  and  $c$  are marked as shown.

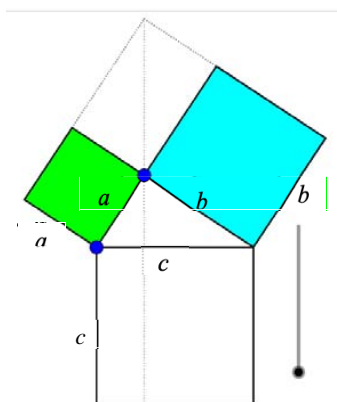


Figure 1

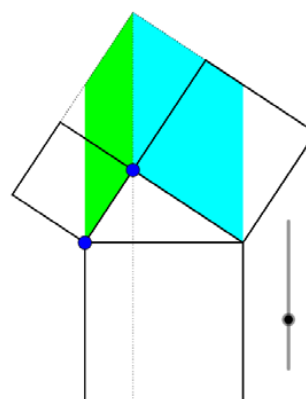


Figure 2

**Q1.** In **Figure 1**, find the area of the green part and blue part in terms of  $a$  and  $b$ .

Area of Green part = \_\_\_\_\_ Area of Blue part = \_\_\_\_\_

**Q2.** In **Figure 2**, find the area of the green parallelogram and blue parallelogram in terms of  $a$  and  $b$ .

(Hint: Use the **Observation**, how are the new parts related to those in **Figure 1**?)

Area of Green part = \_\_\_\_\_ Area of Blue part = \_\_\_\_\_

# Lessons 1 -2

## Lesson Worksheets (8 sets)

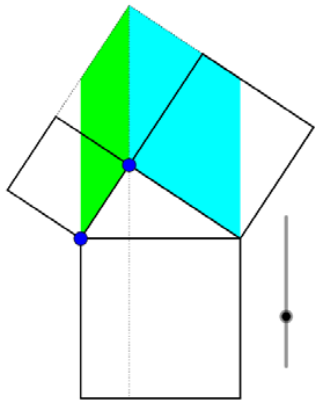


Figure 2

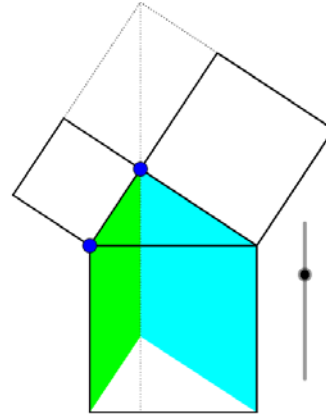


Figure 3

- Q3.** In **Figure 3**, the two parallelograms are transformed.  
 What kind of transformation is it? Will the area be changed after the transformation?  
 T \_\_\_\_\_. The area ( will / will not ) be changed.  
 Area of Green part = \_\_\_\_\_ Area of Blue part = \_\_\_\_\_

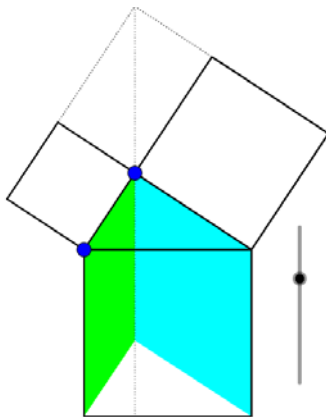


Figure 3

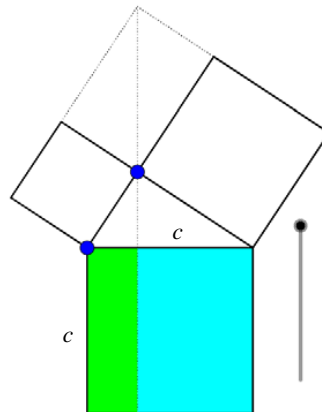


Figure 4

- Q4.** In **Figure 4**, find the area of the green rectangle and blue rectangle in terms of  $a$  and  $b$ .  
 (Hint: Use the **Observation**. How are the new triangles related to those in **Figure 3**?)  
 Area of Green part = \_\_\_\_\_ Area of Blue part = \_\_\_\_\_
- Q5.** In **Figure 4**, find the sum of the two rectangles in terms of  $c$ .  
 Area of Green Triangle + Area of Blue Triangle = \_\_\_\_\_
- Q6.** Can you prove the Pythagoras' Theorem ( $a^2 + b^2 = c^2$ ) using the area relation?



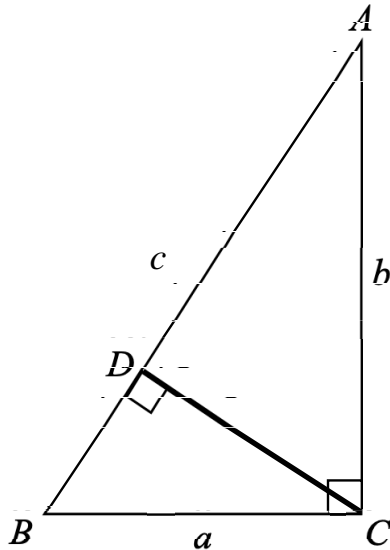
# Lessons 1 -2

## Lesson Worksheets (8 sets)

Name: \_\_\_\_\_ Class: \_\_\_\_\_ ( )

### Set 6 --- Proof by Similar Triangles

[1 page]



Let  $AB = c$ .

**Q1.** What are the relations of the three triangles  $\triangle BAC$ ,  $\triangle BCD$  and  $\triangle CAD$ ?

They are \_\_\_\_\_ triangles.

**Q2.** Following the steps below, prove the Pythagoras' Theorem.

Step.1 Using  $\triangle BAC \sim \triangle BCD$

$$\frac{BD}{BC} = \frac{BC}{BA}$$

$$\frac{BD}{a} = \frac{a}{c}$$

$$BD = \frac{a^2}{c}$$

Step. 3  $c = BD + DA$

$$c = \frac{a^2}{c} + DA$$

$$c = \frac{a^2 + c \cdot DA}{c}$$

$$\therefore c^2 = a^2 + c \cdot DA$$

Step.2 Using  $\triangle BAC \sim \triangle CAD$

$$\frac{DA}{CA} = \frac{CA}{BA}$$

$$\frac{DA}{b} = \frac{b}{c}$$

$$DA = \frac{b^2}{c}$$

# Lessons 1 -2

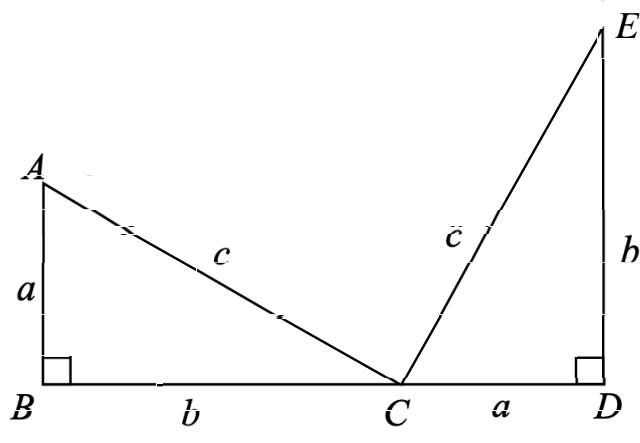
## Lesson Worksheets (8 sets)

Name: \_\_\_\_\_ Class: \_\_\_\_\_ ( )

### Set 7 --- Garfield's proof

\*Garfield is the President of US in 1881.

[1 page]



Draw a line joining  $A$  and  $E$ . A trapezium  $ABDE$  is formed.

**Q1.** Is  $\angle ACE = 90^\circ$  ? Why?

**Q2.** Following the steps below, prove the Pythagoras' Theorem ( $a^2 + b^2 = c^2$ ).

Step.1 Area of Trapezium  $ABDE = \frac{1}{2}(\quad + \quad)(\quad + \quad) = \frac{1}{2}(\quad + \quad)^2$

Step.2 Area of  $\triangle ABC$  + Area of  $\triangle CDE$  + Area of  $\triangle ACE$  (in terms of  $a$ ,  $b$  and  $c$ )  
 $= \frac{1}{2}ab + \frac{1}{2}ab + \frac{1}{2}(\quad)$

Therefore,  $\frac{1}{2}(\quad + \quad)^2 = \frac{1}{2}ab + \frac{1}{2}ab + \frac{1}{2}(\quad)$   
 $(\quad + \quad)^2 = ab + ab + (\quad)$

# Lessons 1 -2

## Lesson Worksheets (8 sets)

Name: \_\_\_\_\_ Class: \_\_\_\_\_ ( )

### Set 8 --- Proof by Similar Triangles

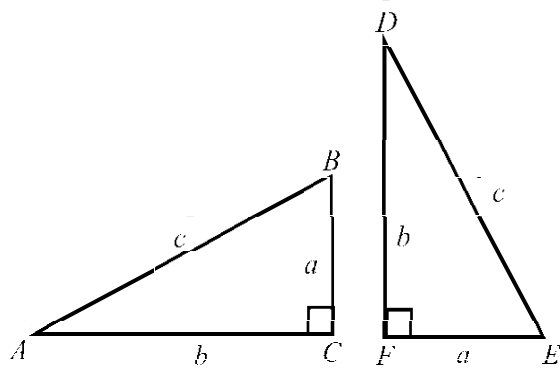


Figure 1

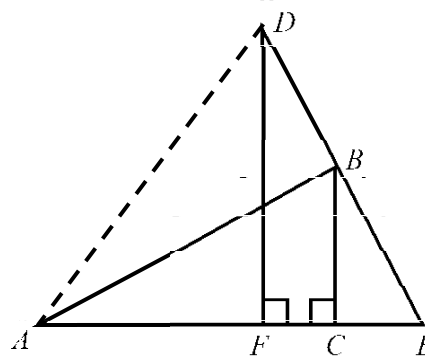


Figure 2

Two congruent right-angled triangles  $ABC$  and  $DEF$  are shown. (Figure 1)

They are then placed such that  $B$  lies on  $DE$  and  $AFCE$  forms a straight line. (Figure 2)

Step 1 In Figure 2,  $DF \parallel BC$  (Reason: \_\_\_\_\_)

Step 2 In Figure 2, Prove that  $\triangle BCE \sim \triangle DFE$ .

$$\begin{aligned} \angle BCE &= \angle DFE = 90^\circ \quad (\text{given}) \\ \angle BEC &= \angle DEF \quad ( \quad ) \\ \angle CBE &= \angle FDE \quad ( \quad ) \\ \therefore \triangle BCE &\sim \triangle DFE \quad ( \quad ) \end{aligned}$$

Step 3 Express the area of  $\triangle ADE$  in terms of  $c$ .

Notice that  $\angle ABE = 90^\circ$

$$\text{Area of } \triangle ADE = \frac{1}{2} \times DE \times AB = \text{---}$$

## Lessons 1 -2

### Lesson Worksheets (8 sets)

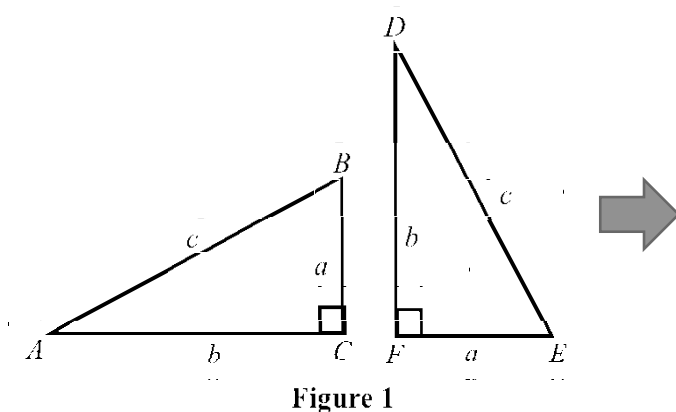


Figure 1

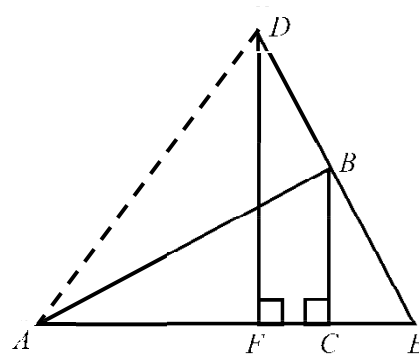


Figure 2

Step.4 Express the area of  $\triangle ADE$  in terms of  $a$  and  $b$  .

$$\because \triangle BCE \sim \triangle DFE,$$

$$\frac{CE}{DF} = \frac{BC}{DE}$$

$$\frac{CE}{b} = \frac{a}{c}$$

$$CE = \frac{ab}{c}$$

$$\begin{aligned} \text{Area of } \triangle ADE &= \frac{1}{2} \times AE \times DF \\ &= \frac{1}{2} \times (AC + CE) \times DF \\ &= \frac{1}{2} \times (b + \frac{ab}{c}) \times b \\ &= \frac{1}{2} \left( b + \frac{ab}{c} \right) \times b \\ &= \end{aligned}$$

Combining Steps 3 and 4 , prove the Pythagoras' Theorem ( $a^2 + b^2 = c^2$ ) .

# Lessons 1 -2

## Suggest Answers and Guidelines

Name: \_\_\_\_\_ Class: \_\_\_\_\_ ( )

### Set 1 --- Proof by Rearrangement [Solution]

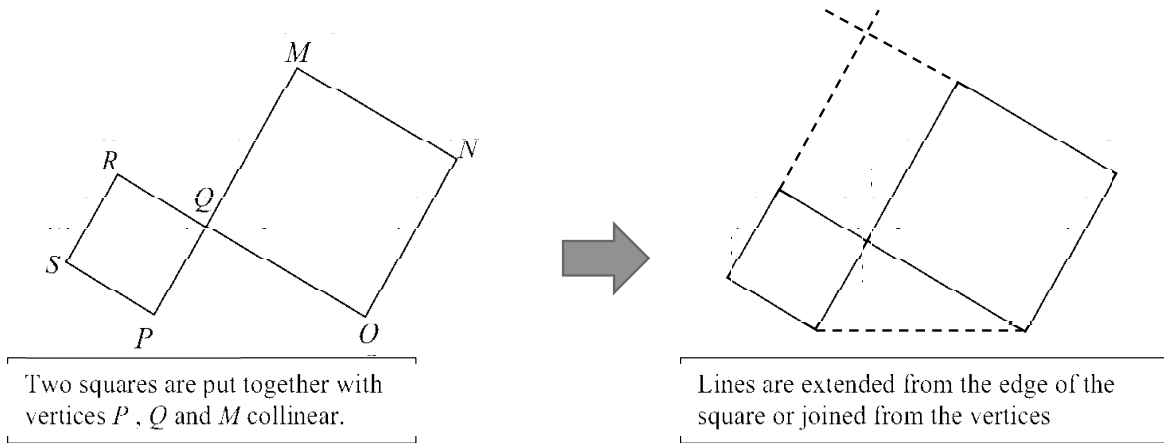
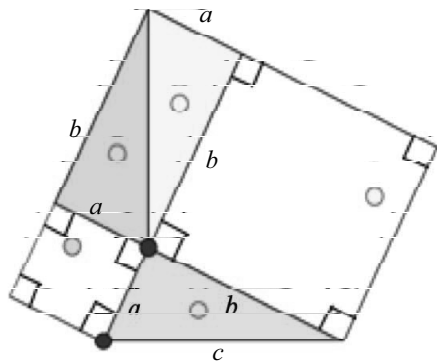


Figure 1 is then formed by cutting the top rectangle into two triangles. As shown.



Q1. Is  $\angle PQO = 90^\circ$ ? Why?

$$\begin{aligned} \angle PQR &= 90^\circ \text{ and } \angle MQO = 90^\circ \text{ (square)} \\ \angle PQO &= 180^\circ - 90^\circ = 90^\circ \text{ (adj. } \angle\text{s on st. line)} \end{aligned}$$

Q2. Are the three triangles congruent? Which reason (SSS, SAS, ASA, AAS, RHS) can explain the congruence?

$$\text{Yes, SAS (the two sides with length } a \text{ and } b \text{, the } 90^\circ \text{.)}$$

Q3. Express the area of the whole figure in terms of  $a$  and  $b$ . [Hint: Three triangles + Two Square]

$$a^2 + b^2 + \frac{3ab}{2}$$

## Lessons 1 -2

### Suggest Answers and Guidelines

Figure 1

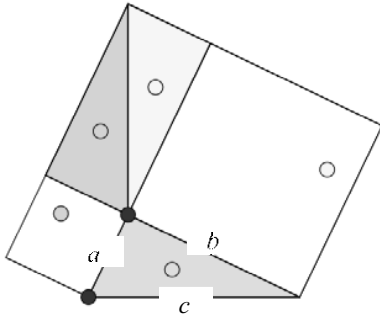
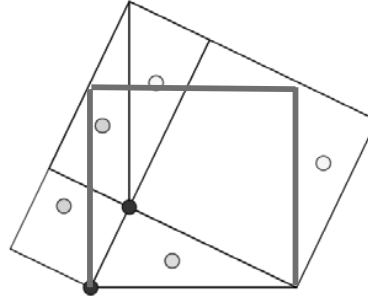


Figure 2



**Q4.** Following the GeoGebra, triangles are moved to new positions. Draw lines in **Figure 2** to show it.

**Q5.** Express the area of the whole figure in terms of  $a$ ,  $b$  and  $c$ . [Hint: Three Triangles + One Square ]

$$c^2 + \frac{3ab}{2}$$

**Q6.** Prove the Pythagoras' Theorem ( $a^2 + b^2 = c^2$ ) using the areas in **Q3** and **Q5**.

$$a^2 + b^2 + \frac{3ab}{2} = c^2 + \frac{3ab}{2}$$

$$a^2 + b^2 = c^2$$



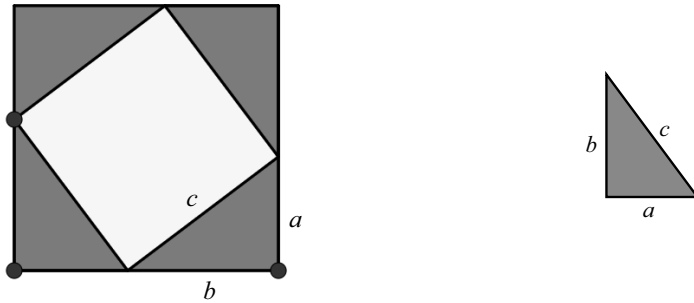
# Lessons 1 -2

## Suggest Answers and Guidelines

Name: \_\_\_\_\_ Class: \_\_\_\_\_ ( )

### Set 2 --- Proof by Rearrangement [Solution]

Figure 1



Q1. How is Figure 1 formed?

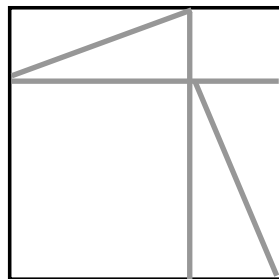
It is formed by rearranging four **congruent** triangles into a big **square** .

Q2. What kind of quadrilateral is formed in the yellow part?

A square (with length  $c$  )

[ Obviously the 4 lengths are all equal to  $c$  ,  
Can ask student to prove the angles are  $90^\circ$  ]

Figure 2 Follow the slider in the Geogebra to draw the new figure obtained.



Q3. Two quadrilateral is formed in the yellow part now. What kind of quadrilaterals are they?

Squares.

# Lessons 1 -2

## Suggest Answers and Guidelines

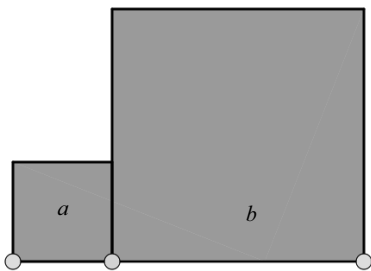
Name: \_\_\_\_\_ Class: \_\_\_\_\_ ( )

### Set 3 --- Proof by Rearrangement [Solution]

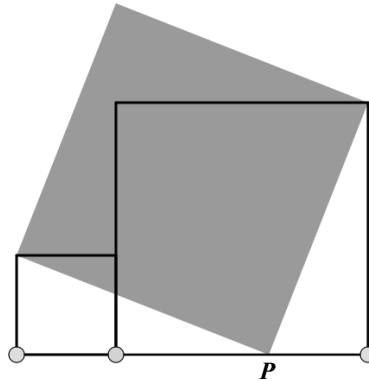
At the beginning, two squares are placed side by side in **Figure 1**.

When you follow the slider in the GeoGebra, two white triangles are formed in **Figure 2**.

**Figure 1**

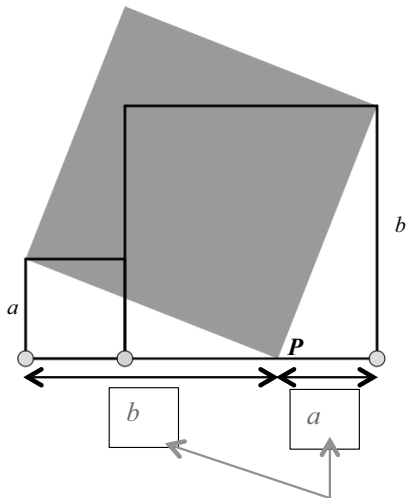


**Figure 2**



Move the green dot to change the size of the squares and observe the change in point *P*.

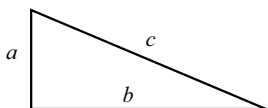
**Figure 3**



Question: Write down the length of these two line segments in terms of *a* and *b*.

Can you prove the Pythagoras' Theorem ( $a^2 + b^2 = c^2$ ) using **Figure 1** and **Figure 3**?

Let *a*, *b* and *c* be the sides of the white triangles as shown.



In **Figure 1**, the purple parts are squares, the total area =  $a^2 + b^2$

In **Figure 3**, the purple part is a square, the area =  $c^2$

Therefore,  $a^2 + b^2 = c^2$

# Lessons 1 -2

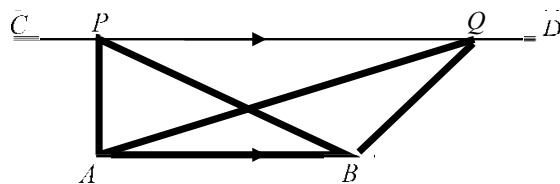
## Suggest Answers and Guidelines

Name: \_\_\_\_\_ Class: \_\_\_\_\_ ( )

### Set 4 --- Proof by Area Relation [Solution]

**Observation:** Given two parallel line segments  $AB$  and  $CD$ .

Two triangles  $APB$  and  $AQB$  are drawn with  $AB$  as their common base.



What is the relation of the Area of  $\triangle APB$  and  $\triangle AQB$ ?

Hint: Two triangles have the same base  $AB$ , how about the heights?

**The height is the same. Therefore, the area are equal.**

Following the slider in the Geogebra, Figures are obtained. Lengths  $a$ ,  $b$  and  $c$  are marked as shown.

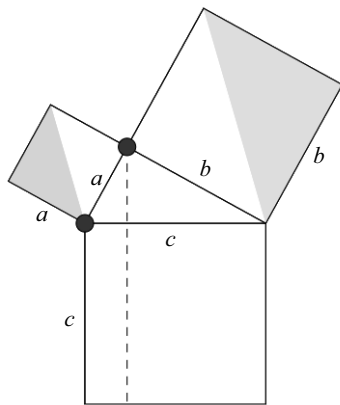


Figure 1

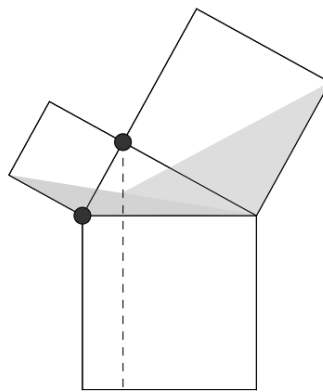


Figure 2

**Q1.** In Figure 1, find the area of the green triangle and blue triangles in terms of  $a$  and  $b$ .

$$\text{Area of Green Triangle} = \frac{a^2}{2}$$

$$\text{Area of Blue Triangle} = \frac{b^2}{2}$$

**Q2.** In Figure 2, find the area of the green triangle and blue triangles in terms of  $a$  and  $b$ .

(Hint: Use the **Observation**. How are the new triangles related to those in **Figure 1**?)

$$\text{Area of Green Triangle} = \frac{a^2}{2}$$

$$\text{Area of Blue Triangle} = \frac{b^2}{2}$$

# Lessons 1 -2

## Suggest Answers and Guidelines

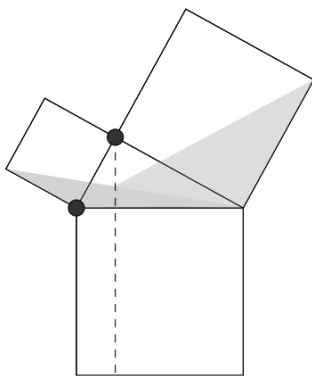


Figure 2

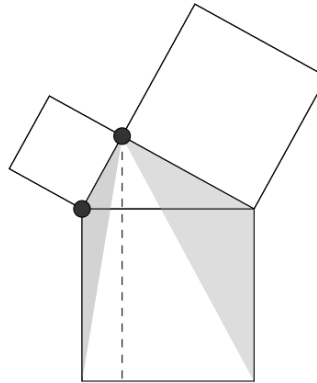


Figure 3

**Q3.** In **Figure 3**, the two triangles are transformed.

What kind of transformation is it? Will the area be changed after the transformation?

**Rotation.** The area (~~will~~/ will not ) be changed.

$$\text{Area of Green Triangle} = \frac{a^2}{2}$$

$$\text{Area of Blue Triangle} = \frac{b^2}{2}$$

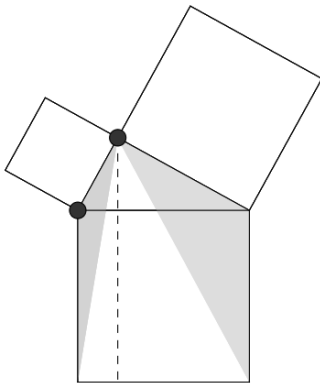


Figure 3

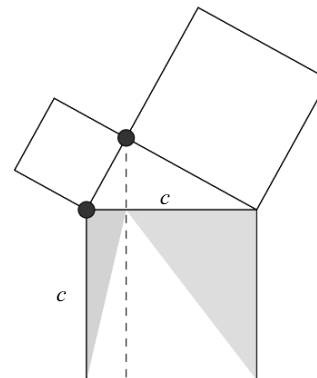


Figure 4

**Q4.** In **Figure 4**, find the area of the green triangle and blue triangle in terms of  $a$  and  $b$ .

(Hint: Use the **Observation**. How are the new triangles related to those in Figure 3?)

$$\text{Area of Green Triangle} = \frac{a^2}{2}$$

$$\text{Area of Blue Triangle} = \frac{b^2}{2}$$

**Q5.** In **Figure 4**, the two triangles are now inside the square with side  $c$ .

Find the sum of the two triangles in terms of  $c$ .

$$\text{Area of Green Triangle} + \text{Area of Blue Triangle} = \frac{c^2}{2}$$

(Hint: What is the fraction of the area of two triangles compared to the square with side  $c$ .)

**Q6.** Can you prove the Pythagoras' Theorem ( $a^2 + b^2 = c^2$ ) using the area relation?

$$\frac{a^2}{2} + \frac{b^2}{2} = \frac{c^2}{2} \Rightarrow a^2 + b^2 = c^2$$

# Lessons 1 -2

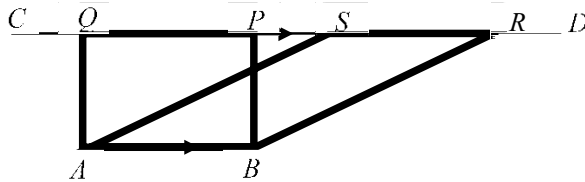
## Suggest Answers and Guidelines

Name: \_\_\_\_\_ Class: \_\_\_\_\_ (

### Set 5 --- Proof by Area Relation [Solution]

**Observation:** Given two parallel line segments  $AB$  and  $CD$ .

A rectangle  $ABPQ$  and parallelogram  $ABRS$  are drawn with  $AB$  as their common base.



What is the relation of the Area of rectangle  $ABPQ$  and parallelogram  $ABRS$  ?

(Hint: They have the same base  $AB$ . How about the heights?)

**The height is the same. Therefore, the area is equal.**

Following the slider in the Geogebra, Figures are obtained. Lengths  $a$ ,  $b$  and  $c$  are marked as shown.

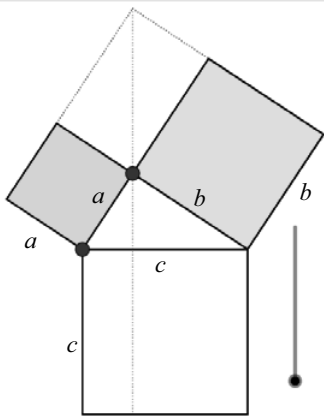


Figure 1

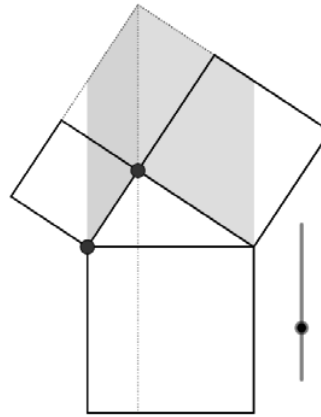


Figure 2

**Q1.** In **Figure 1**, find the area of the green part and blue part in terms of  $a$  and  $b$ .

Area of Green part =  $a^2$

Area of Blue part =  $b^2$

**Q2.** In **Figure 2**, find the area of the green parallelogram and blue parallelogram in terms of  $a$  and  $b$ .

(Hint: Use the **Observation**, how are the new parts related to those in **Figure 1**?)

Area of Green part =  $a^2$

Area of Blue part =  $b^2$

# Lessons 1 -2

## Suggest Answers and Guidelines

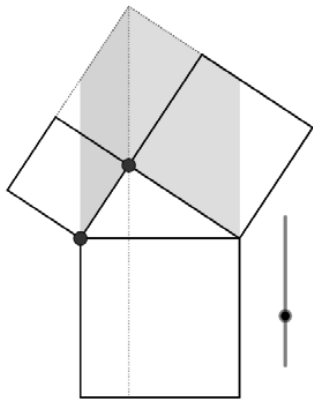


Figure 2

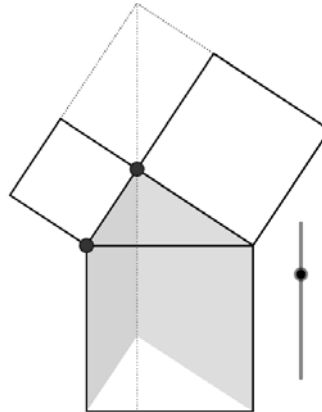


Figure 3

- Q3. In Figure 3, the two parallelograms are transformed.  
 What kind of transformation is it? Will the area be changed after the transformation?

**Translation.** The area (~~will~~/ will not ) be changed.

Area of Green part =  $a^2$

Area of Blue part =  $b^2$

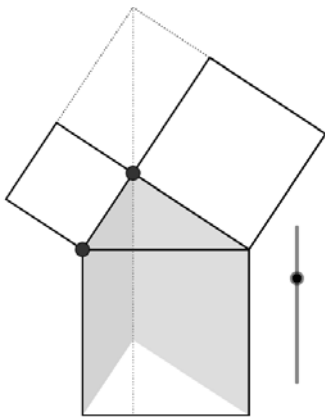


Figure 3

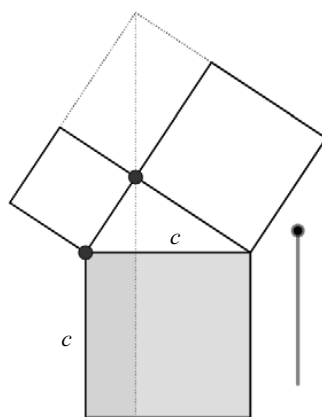


Figure 4

- Q4. In Figure 4, find the area of the green rectangle and blue rectangle in terms of  $a$  and  $b$ .  
 (Hint: Use the **Observation**. How are the new triangles related to those in Figure 3?)

Area of Green part =  $a^2$

Area of Blue part =  $b^2$

- Q5. In Figure 4, find the sum of the two rectangles in terms of  $c$ .

Area of Green Triangle + Area of Blue Triangle =  $c^2$

- Q6. Can you prove the Pythagoras' Theorem ( $a^2 + b^2 = c^2$ ) using the area relation?

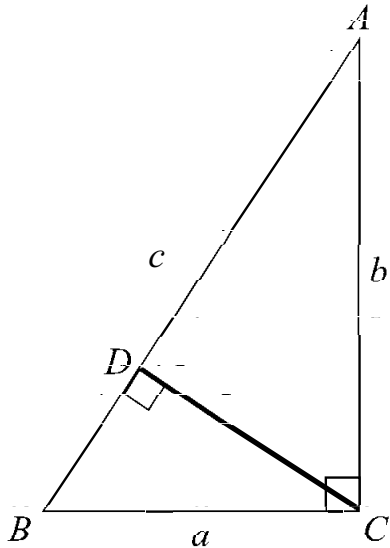
$a^2 + b^2 = c^2$

## Lessons 1 -2

### Suggest Answers and Guidelines

Name: \_\_\_\_\_ Class: \_\_\_\_\_ ( )

#### Set 6 --- Proof by Similar Triangles [Solution]



Let  $AB = c$

Q1 What are the relations of the three triangles  $\triangle BAC$ ,  $\triangle BCD$  and  $\triangle CAD$ ?

They are **similar** triangles.

Q2 Following the steps below, prove the Pythagoras' Theorem .

Step.1 Using  $\triangle BAC \sim \triangle BCD$

$$\frac{BD}{BC} = \frac{BC}{BA}$$

$$\frac{BD}{a} = \frac{a}{c}$$

$$BD = \frac{a^2}{c}$$

Step. 3

$$c = BD + DA$$

$$c = \text{---} + \text{---}$$

$$c = \frac{\text{---}}{c}$$

$$\therefore c^2 = a^2 + b^2$$

Step.2 Using  $\triangle BAC \sim \triangle CAD$

$$\frac{DA}{CA} = \frac{CA}{BA}$$

$$\frac{DA}{b} = \frac{b}{c}$$

$$DA = \frac{b^2}{c}$$



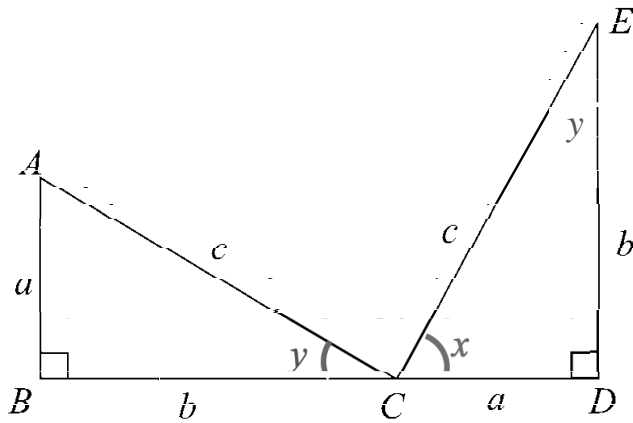
## Lessons 1 -2

### Suggest Answers and Guidelines

Name: \_\_\_\_\_ Class: \_\_\_\_\_ ( )

#### Set 7 --- Garfield's proof [Solution]

\*Garfield is the President of US in 1881.



Draw a line joining A and E. A trapezium  $ABDE$  is formed.

Q1 Is  $\angle ACE = 90^\circ$  ? Why?

$$\begin{aligned} x + y + 90^\circ &= 180^\circ \text{ (}\angle \text{ sum of } \Delta\text{)} \\ x + y &= 90^\circ \\ x + y + \angle ACE &= 180^\circ \text{ (adj. } \angle\text{s of st. line)} \\ 90^\circ + \angle ACE &= 180^\circ \\ \angle ACE &= 90^\circ \end{aligned}$$

Q2 Following the steps below, prove the Pythagoras' Theorem ( $a^2 + b^2 = c^2$ ).

Step.1 Area of Trapezium  $ABDE = \frac{1}{2}(a+b)(a+b) = \frac{1}{2}(a+b)^2$

Step.2 Area of  $\triangle ABC$  + Area of  $\triangle CDE$  + Area of  $\triangle ACE$  (in terms of  $a$ ,  $b$  and  $c$ )

$$= \frac{1}{2}ab + \frac{1}{2}ab + \frac{1}{2}(c^2)$$

Therefore,  $\frac{1}{2}(a+b)^2 = \frac{1}{2}ab + \frac{1}{2}ab + \frac{1}{2}(c^2)$

$$(a+b)^2 = ab + ab + (c^2)$$

$$a^2 + 2ab + b^2 = 2ab + c^2$$

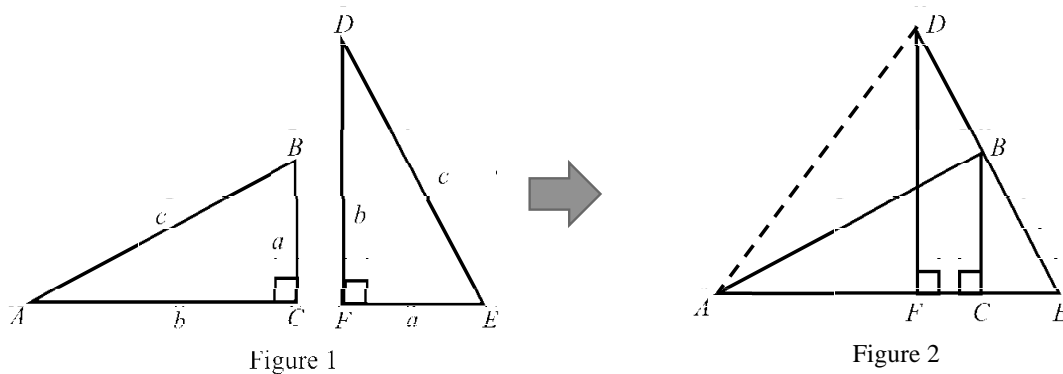
$$a^2 + b^2 = c^2$$

## Lessons 1 -2

### Suggest Answers and Guidelines

Name: \_\_\_\_\_ Class: \_\_\_\_\_ )

( Set 8 --- Proof by Similar Triangles [Solution]



Two congruent right-angled triangles  $ABC$  and  $DEF$  are shown. (Figure 1)

They are then placed such that  $B$  lies on  $DE$  and  $AFCE$  forms a straight line. (Figure 2)

Step 1 In Figure 2,  $DF \parallel BC$  (Reason: **int.  $\angle$ s supp.** )

Step 2 In Figure 2, Prove that  $\triangle BCE \sim \triangle DFE$ .

$$\begin{aligned} \angle BCE &= \angle DFE = 90^\circ && \text{(given)} \\ \angle BEC &= \angle DEF && \text{(common } \angle \text{ )} \\ \angle CBE &= \angle FDE && \text{(3rd } \angle \text{ )} \\ \therefore \triangle BCE &\sim \triangle DFE && \text{( A.A.A. )} \end{aligned}$$

Step 3 Express the area of  $\triangle ADE$  in terms of  $c$ .

Notice that  $\angle ABE = 90^\circ$

$$\text{Area of } \triangle ADE = \frac{1}{2} \times DE \times AB = \frac{c^2}{2}$$

## Lessons 1 -2

### Suggest Answers and Guidelines

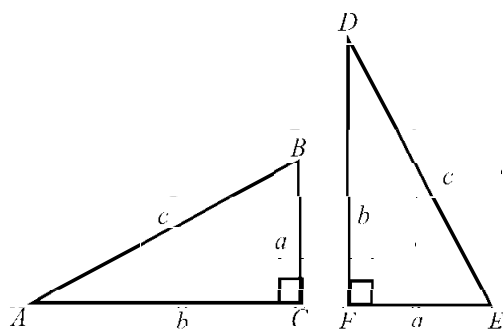


Figure 1

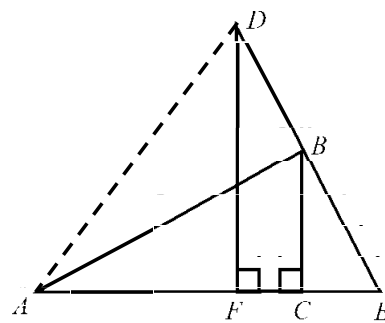


Figure 2

Step.4 Express the area of  $\triangle ADE$  in terms of  $a$  and  $b$  .

$$\because \triangle BCE \sim \triangle DFE,$$

$$\frac{CE}{EF} = \frac{BC}{DF}$$

$$\frac{CE}{a} = \frac{a}{b}$$

$$CE = \frac{a^2}{b}$$

$$\begin{aligned} \text{Area of } \triangle ADE &= \frac{1}{2} \times AE \times DF \\ &= \frac{1}{2} \times (AC + CE) \times DF \\ &= \frac{1}{2} \times \left(b + \frac{a^2}{b}\right) \times b \\ &= \frac{1}{2} \left(\frac{b^2 + a^2}{b}\right) \times b \\ &= \frac{1}{2} (b^2 + a^2) \end{aligned}$$

Combining steps 3 and 4 , prove the Pythagoras' Theorem ( $a^2 + b^2 = c^2$ ) .

$$\begin{aligned} \frac{c^2}{2} &= \frac{1}{2} (b^2 + a^2) \\ c^2 &= b^2 + a^2 \end{aligned}$$

## Lessons 1-2

### Extension Reading Materials and Worksheet

#### 中國數學家與畢氏定理

#### 畢氏定理的名稱

幾何學裏有一個非常重要的定理——畢達哥拉斯定理(或簡稱畢氏定理)。畢達哥拉斯是約於公元前 500 年的希臘哲學家、天文學家、數學家和音樂家。雖然這定理稱為畢氏定理，但是仍然有討論指出有比畢達哥拉斯更早的數學家已發現這定理。在我國，這個定理稱為勾股定理，或在台灣省稱為商高定理。勾、股是指直角三角形內較短的兩邊（弦是指三角形內的斜邊），而商高則是約於公元前 1100 年周朝時代的人物。這兩個名字均出現於我國有名的《周髀算經》內。

在中國流傳至今最古老的一部天算典籍《周髀算經》中，第一章便記述周公與商高<sup>1</sup> 的問答，由於商高的答辭中論述了勾股定理的特例“句<sup>2</sup>廣三，股修四，徑隅五”的內容。除此，在《周髀算經》卷內之二記載榮方與陳子問答中，亦有陳子講述：「句股各自乘，并而開方得之」。用現代數學符號表示，即是  $a^2 + b^2 = c^2$ ，其中  $a$ 、 $b$  及  $c$  分別是直三角形的兩邊而  $c$  是斜邊。可見在當時已知勾股定理。

雖然《周髀算經》的成書年代估計為在公元前一世紀至公元一世紀<sup>3</sup>，不過書中內容則可能在成書前便已產生，如公元前十一世紀<sup>4</sup>。因此歷來便有討論，“勾股定理”在中國何時已有嚴格的證明及應否將畢氏定理正名為勾股定理。

勾股定理不僅是最古老的數學定理之一，也是數學中證法最多的一個定理，幾千年來，人們已經發現了 400 多種不同的證明方法，足以編成厚厚的一本書。

閱讀以下段落並回答問題。

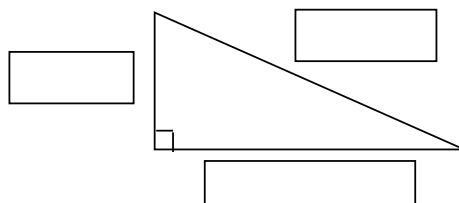
1. (a) 列出相等於畢氏定理的名稱。

\_\_\_\_\_

- (b) 有多少個已知證明畢氏定理的方法？

\_\_\_\_\_

2. 在圖中於對應位置寫出三角形內的“勾”、“股”、“弦”的名稱。



<sup>1</sup> “從「中國方志從書 商南縣志」卷八“人物志”中查獲一條有關商高生平的記載：[周]商高，黃帝之昆孫。以地得姓。周初封子男於商。精數學，[周髀]衍其說為算經。「國語」曰司商。” 曲安京(1996)

<sup>2</sup> “句”為“勾”的古字。

<sup>3</sup> 李儼(1992)。《中國古代數學簡史》第 32 頁。

<sup>4</sup> 關於「商南縣志」及上述文字的作者及出處，……，十分可信，商高為西周初期(約公元前十一世紀)的數學家殆無疑問。” 曲安京(1996)

## Lessons 1 -2

### Extension Reading Materials and Worksheet

3. (a) 在希臘，畢氏定理大約於那年被“發現”出來呢？

\_\_\_\_\_

(b) 《周髀算經》大約於那年出現？為何不能準確說出勾股定理的出現年份？

\_\_\_\_\_

\_\_\_\_\_

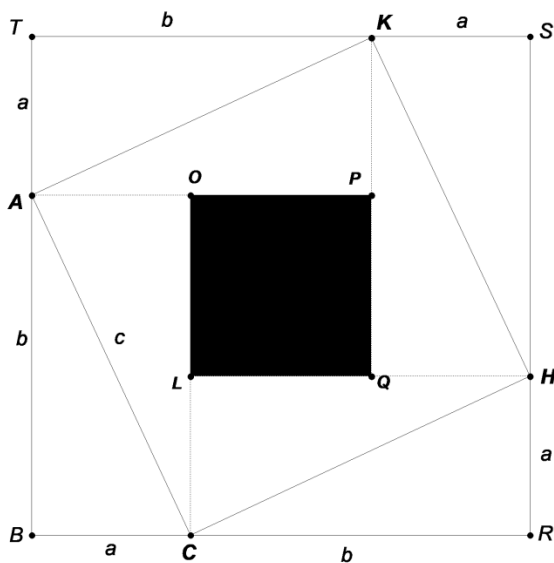
(c) 解釋為何有言論指畢氏定理應稱為勾股定理。

\_\_\_\_\_

\_\_\_\_\_

### 趙爽的證明方法

趙爽(約於公元 300 年)在為《周髀算經》內勾股定理作注釋，所用的證明方法，在以下方空格內將該證明以數學語言重新改寫。



證明：

\_\_\_\_\_

\_\_\_\_\_

\_\_\_\_\_

\_\_\_\_\_

\_\_\_\_\_

\_\_\_\_\_

\_\_\_\_\_

\_\_\_\_\_

\_\_\_\_\_

\_\_\_\_\_

\_\_\_\_\_

## Lessons 1 -2

### Extension Reading Materials and Worksheet

#### 劉徽的證明

與趙爽同期，中國的另一數學家劉徽亦發現了一奇妙證明勾股定理的方法。劉徽的方法是完全不用代數方法來作出證明。他的方法以當時文字記錄如下：

句<sup>1</sup>自乘為朱方，股自乘為青方，令出入相補，各從其類，因就其餘不移動也。合成弦方之畧，開方除之，即弦也。

劉徽的方法：

劉徽首先作出三角形上兩條直角邊上的正方形，他把由一條直角邊形成的正方形叫做“朱方”，而另一條直角邊形成的正方形叫做“青方”（見圖一），然後把圖中標注有“出”的那部分圖形，移到標注有“入”的那些位置，就拼成了圖中斜置的那個正方形（見圖二）。

劉徽把斜置的那個正方形叫做“弦方”，它正好是由直角三角形斜邊形成的一個正方形。

經過這樣一番移、合、拼、補，自然而然地得出了結論：

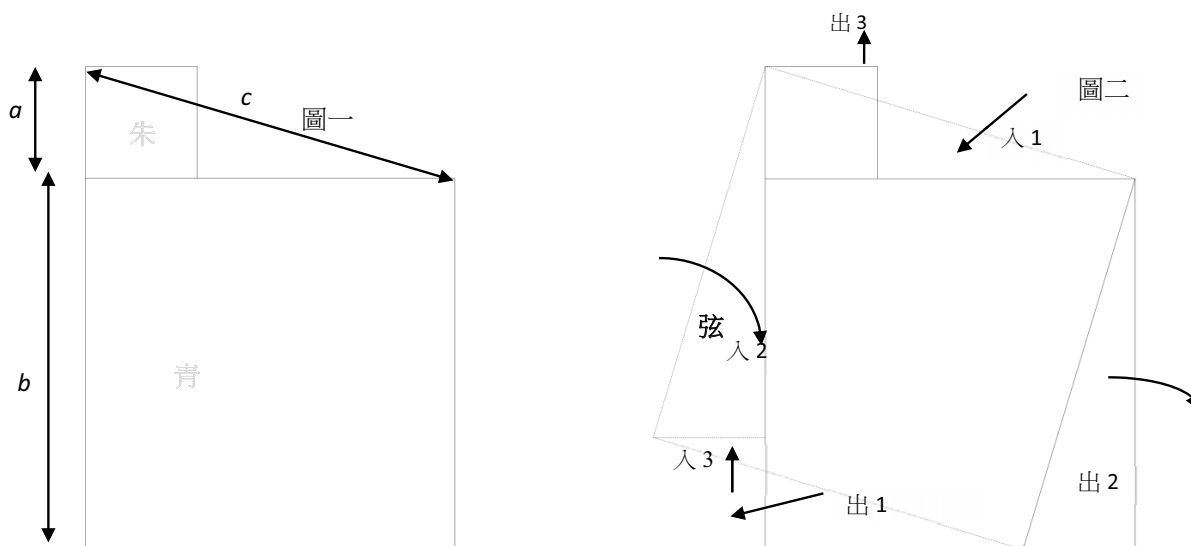
$$\text{朱方} + \text{青方} = \text{弦方}$$

$$\text{即} \quad a^2 + b^2 = c^2。$$

“青朱出入圖”是一幅多麼神奇的圖！它甚至不用去標注任何文字，只要相應地塗上朱、青兩種顏色，便能把蘊含於勾股定理中的數學真理，清晰地展示在世人面前。

摘錄自李天華、許濟華編著(1995)。《數學奇觀》。第 61 頁。中國台灣：九章出版社。

註 1: “句”為“勾”字的古代用字。



## Lessons 1 -2

### Extension Reading Materials and Worksheet

蘆葦問題(或在印度稱為蓮花問題)

在《九章算術》的第九章(勾股章)內的一道出名的蘆葦問題如下：

“葭生中央問題”

今有池方一丈，葭生其中央，出水一尺，引葭赴岸，適與岸齊，問水深葭長各幾何？

轉為現代中文的意思如下：

有一個正方形的池塘，邊長為 1 丈<sup>1</sup>，有棵蘆葦生長在池塘的正中央，高出水面的部分有 1 尺長，如果把蘆葦向岸邊拉，葦頂正好能碰到池岸邊沿。問池塘水深和蘆葦的長度各是多少？

根據上文，畫出題意，並解決問題。

題解：

書內提供的題解，以近代語文寫成如下：

把池塘邊長的一半自乘，再把蘆葦出水的那部分自乘，然後相減，將所得的差除以出水數的 2 倍，就是池塘的水深，加上出水數，就是蘆葦的長度。

解釋為何以上方法能找到答案。



## Lessons 1 -2

### Extension Reading Materials and Worksheet

解答：

畢氏定理的名稱

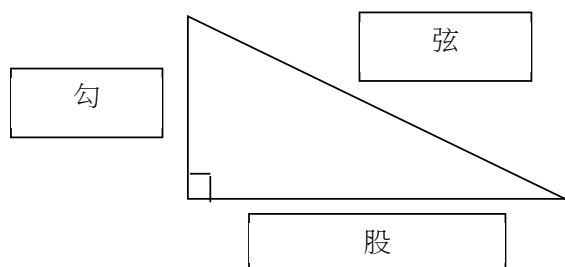
1. (a) 盡量寫出相等於畢氏定理的名稱。

勾股定理, 商高定理

- (b) 有多少個已知證明畢氏定理的方法？

400 多個

2. 在圖中於對應位置寫出三角形內的“勾”、“股”、“弦”的名稱。



3. (a) 在希臘，畢氏定理大約於那年被“發現”出來呢？

公元前 500 年

- (c) 《周髀算經》大約於那年出現？為何不能準確說出勾股定理的出現年份？  
 公元前 1 世紀至公元 1 世紀，因書中內容可能更早已出現。

- (c) 簡單解釋為何有言論指畢氏定理應稱為勾股定理。

因為中國可能比希臘的畢達哥拉斯更早發現或證明了該定理。

### 趙爽的證明方法

證明：

$$4\left(\frac{1}{2}ab\right) = c^2 - (b-a)^2$$

$$2ab = c^2 - (b^2 - 2ab + a^2)$$

$$2ab = c^2 - b^2 + 2ab - a^2$$

$$a^2 + b^2 = c^2$$

## Lessons 1 -2

### Extension Reading Materials and Worksheet

蘆葦問題(或在印度稱為蓮花問題)

畫出以上題意並解決以上問題。

題解：

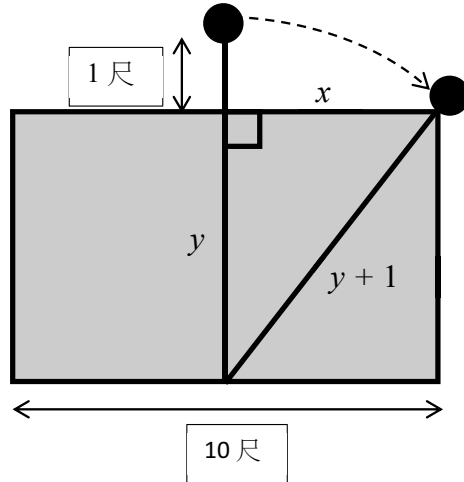
$$x = \frac{10}{2} = 5$$

$$y^2 + 5^2 = (y+1)^2$$

$$y^2 + 5^2 = y^2 + 2y + 1^2$$

$$5^2 - 1^2 = 2y$$

$$\frac{5^2 - 1^2}{2} = y$$



書內提供的題解，以近代語文寫成如下：

把池塘邊長的一半自乘，再把蘆葦出水的那部分自乘，然後相減，將所得的差除以出水數的 2 倍，就是池塘的水深，加上出水數，就是蘆葦的長度。

解釋為何以上方法能找到答案。設池塘邊長為  $a$ ，出水部分為  $b$ 。

$$y^2 + \left(\frac{a}{2}\right)^2 = (y+b)^2$$

$$y^2 + \left(\frac{a}{2}\right)^2 = y^2 + 2by + b^2$$

$$2by = \left(\frac{a}{2}\right)^2 - b^2$$

## Grouping Method

The following figure is a sample which demonstrates the grouping.

In the first grouping, teacher groups students based on their mathematical ability. Teacher will make sure there are some students with good leadership or communication skills in each group to ensure smooth group discussion.




The second grouping is just generated by the computer by picking one student from each of the 4 groups.

<b>First Grouping (Group by Mathematical Ability)</b>			
<b>Group 1 (Worksheet 1)</b>		<b>Group 3 (Worksheet 3)</b>	
Annie	Bianca	Alan	Becky
Candy	Donald	Calvin	Debbie
<b>Group 2 (Worksheet 2)</b>		<b>Group 4 (Worksheet 4)</b>	
Angel	Ben	Anthony	Brenda
Connie	Derek	Cali	Daniel
<b>Second Grouping (Mixing Four Groups from First Grouping)</b>			
<b>Group 1</b>		<b>Group 3</b>	
Annie	Alan	Bianca	Becky
Angel	Anthony	Ben	Brenda
<b>Group 2</b>		<b>Group 4</b>	
Candy	Calvin	Donald	Debbie
Connie	Cali	Derek	Daniel

# Golden Ratio and Fibonacci Sequence

**Grade: Secondary 2**

**No. of Lessons (Learning Time): 2 Consecutive Lessons (80 minutes in total)**

<b>Prior Knowledge</b>	<ul style="list-style-type: none"> <li>- Basic knowledge of ratio</li> <li>- Pythagoras' Theorem</li> <li>- Fibonacci Sequence</li> <li>- Similar Figures</li> <li>- Surds</li> </ul>
<b>Learning Objectives</b>	<ul style="list-style-type: none"> <li>- Students can investigate the relationship between Golden Ratio and Fibonacci sequence</li> <li>- Students explore the application of Golden Ratio in real life</li> <li>- The aesthetic sense of the students can be developed</li> </ul>
<b>Intended Learning Outcomes</b>	<ul style="list-style-type: none"> <li>- Students deal with the counting problem in a systematical way</li> <li>- Students discover that the ratio of successive terms approaches to a value</li> <li>- Students are willing to challenge themselves</li> <li>- Students are willing to present their findings</li> <li>- Students appreciate one another during group discussions and presentation</li> </ul>
<b>Learning &amp; Teaching Strategies</b>	Ability Grouping, Presentation
<b>Operation Mode of Gifted Education</b>	Level 1: School-based Whole-class Teaching
<b>Core Elements of Gifted Education</b>	<ul style="list-style-type: none"> <li> Higher-order Thinking Skills</li> <li> Creativity</li> <li> Personal-social Competence</li> </ul>

## Foreword / Background

The Project School has classes of about 30 students with mixed Mathematical ability. Most students have a good foundation in Mathematics and are willing to engage with challenging Mathematics lessons. In each class, there are about 5 to 10 students with outstanding performance in Mathematics or gifted in Mathematics. These students have regular training in a pull-out Mathematics programme in the school. Seeing the potential of the students, teachers would like to enrich and extend the regular curriculum so students can find the lessons more challenging and engaging. Their idea matches Level 1B of the three-tier implementation model for gifted education in Hong Kong.

When students were in S1, teachers gave a rough introduction to the ‘Fibonacci sequence’ when they were teaching the topic ‘Sequence’. As students are learning the topic ‘Ratio’ in S2, teachers would like to introduce the Golden Ratio as an enrichment topic. The Golden Ratio is closely related to the Fibonacci Sequence. To study the relation, students need to apply knowledge across different Mathematics topics like Pythagoras’ Theorem, ratio and similar figures. To study the exact value of the Golden Ratio, advanced topics like quadratic equations and irrational numbers are also needed. Education Bureau (2017) suggested that the aims of the Mathematics Education KLA Curriculum include helping students develop number sense, measurement sense, the capacity to appreciate structures and patterns and an appreciation of the aesthetic nature of Mathematics. The study of the Golden Ratio and the Fibonacci Sequence involves recognition of number patterns and appreciation of the aesthetic aspects of Mathematics. Hence, the Golden Ratio and the Fibonacci Sequence can be a suitable topic for providing enrichment and challenge for these students.

## Objectives of Collaboration

The aim of the collaboration is to design a lesson for the whole class with the topic Golden Ratio and Fibonacci Sequence. The lesson aims to expose students to advanced Mathematics topics and challenging problems. As students like to take up a challenge, the lesson would be designed to have more student-centred problem-solving tasks rather than direct teaching. To solve the problems, students are expected to apply knowledge across different Mathematics topics. Through these problems, they are also expected to refine their problem solving and Mathematical thinking skills.

Students with high Mathematical ability or students gifted in Mathematics can have a chance to unleash their potential when solving more challenging problems. When advanced topics are introduced, these students can also extend their learning. During the problem-solving activities, these students might also have a chance to take up leading roles such as guiding other classmates or presenting their solution to the whole class

## Theoretical Framework

The above objectives cannot be easily reached in a whole-class setting. Teachers are encouraged

to adopt differentiated instruction strategies. Differentiated instruction means that teachers proactively plan and carry out varied approaches to the learning content, process and product in response to student differences in readiness, interest, and learning needs (Tomlinson, 2005).

Tomlinson (2005) has developed a graphic tool called an “Equalizer” which comprises nine continuums along which the difficulty level of lesson content, process, or product may be located. It can help teachers expand the repertoire of ways they think about varying the challenge level of a specific task. When teachers design tiered learning tasks or resources to respond to differences in student readiness, they are trying to adjust the difficulty level of the task so that all students experience a challenge that is neither too great nor too small. The gifted and high ability students can experience a more challenging task where their potential can be unleashed. Teachers, with reference to students’ ability and characteristics, can adjust the curriculum or teaching strategies by moving the control to the most suitable position to meet the different learning needs of students.

Tomlinson (2005) also suggested that differentiated instruction is a blend of whole-class, group, and individual instruction. Teachers monitor the match between learner and learning activities and make adjustments to guarantee effective matches.

### Learning and Teaching Strategies

In the lesson, students were grouped according to their Mathematical ability and tiered assignments were prepared to provide an appropriate fit for different ability groups. Following the suggestion by Education Bureau (2017) for preparing a tiered assignment, teachers may first consider the instructional level of average students. Then the assignment can be modified to become more challenging by increasing the level of difficulty and complexity for the Mathematically gifted students. Thus, the lesson was first designed to have the following learning tasks:

<b>Task 1</b>	<b>Study scenarios about Fibonacci Sequence in nature</b>
<b>Task 2</b>	<b>State with formal Mathematics notation the definition of Fibonacci Sequence</b>
<b>Task 3</b>	<b>Find the ratios of consecutive terms in Fibonacci Sequence and determine whether the value approaches a certain value</b>
<b>Task 4</b>	<b>Understand the definition of Golden Rectangle and Golden Ratio and find the exact value (in surd form) of Golden Ratio</b>
<b>Task 5</b>	<b>Study scenarios about Golden Ratio in design and architecture</b>

These five learning tasks were then developed into three sets of worksheets to match the ability groups. In the three sets of worksheets, Task 2, Task 3 and Task 5 are almost the same while Task 1 and Task 4 are different. Task 1 and Task 4 in different sets of worksheets were designed to have a varied challenge level based on the Equalizer.

For Task 1, the teacher developed 3 sets of tasks using three different scenarios about the Fibonacci Sequence in nature. For the groups with lower ability, they study a scenario about flowers by counting the pedals from the picture. It is more concrete and simple. For medium and high ability groups, they study scenarios which require students to list and count things systematically. The tasks for these two groups are more complex and abstract.

Task 4 is the most challenging part of the lesson, the groups with lower ability are given a task requiring them to do a geometric construction using rulers and a pair of compasses. Then, they need to apply Pythagoras' Theorem and knowledge about surds to find out the exact value of the Golden Ratio. For the medium ability and high ability groups, they need to make use of quadratic formula to find out the exact value. The task for lower ability groups requires smaller leaps while that for the other two groups requires greater leaps. Also, a more concrete example about quadratic formula and more hints are provided in the worksheet for medium ability groups while nearly no hints are given to the high ability groups. Hence, the high ability groups are more independent compared to the medium ability groups. Furthermore, hint cards are prepared to better support students in need and extra learning materials (online video clip, extension worksheet) are prepared for groups that finish earlier.

Task 5 is not a difficult task but much time is needed for students to measure the lengths with rulers. Hence, the teacher planned to introduce the task in the lesson and leave it with the students as a post-lesson exercise.

As some of the tasks are different among the groups, the time for student presentation will be reserved so that students know what other groups are studying and learn from one another. Students with good presentation skills can be assigned to be presenters prior to the lesson. Hence, the lesson would involve both small group discussion, whole class instruction and student presentation.

## Discussion

The lesson was conducted in two classes in the Project School. The Project GIFT team participated in one of the classes as observers. Students finished Task 1 to Task 3 smoothly. Only a few groups needed hints from teachers. Some faster groups were provided with I-Pads to view extra learning materials while waiting for the others. For Task 4, the most challenging task, only a few groups could finish without teacher's help. The teacher provided hint cards to the groups at different times depending on students' progress. For some groups, the teacher sat in and guided the students to solve the problem. After the presentation for Task 4, time was up and Task 5 was left as a post-lesson exercise. Overall, all students were highly engaged in the learning tasks and their



presentation of findings were impressive. The teacher maintained a facilitative role and wrapped up different parts of the lesson skilfully. The results of lesson observation indicated that the designed curriculum content and learning activities were effective in enhancing students' engagement in solving challenging problems.

The teacher who conducted the lesson reflected that it was hard to estimate the time required by students for the learning tasks. That was why she prepared some I-Pad and online learning materials for students. It was also difficult to support all the groups in a class with 30 students. Teachers who would like to conduct similar lesson are advised to make good use of hint cards. Teachers can also allow students to decide whether they need hint cards. To facilitate group works, the teacher pre-assigned group leaders and presenters so students did not waste time assigning roles in the lesson. Observers found this measure very useful.

To conclude, if students have good foundations and interest in Mathematics, teachers can enrich the curriculum so students can learn beyond the regular curriculum. With good adjustment of the learning tasks, all students, not only gifted students or students with high ability, can benefit from the provision of such enrichment.







# Lesson Plan



## Lesson 1 - 2

### Pre-lesson Tasks

1. Finish Pre-lesson Worksheet and learn about the use of ratio in daily life.
2. Students are arranged into groups of 3 to 4 students by teachers, matching students' Mathematical ability to the 3 sets of lesson worksheet [Set 1 – Easy, Set 2 – Medium, Set 3 – Hard]. Students can be seated according to this grouping at the beginning of the lesson.

### Procedure

Learning Focus (Time)	Activity / Content	Learning & Teaching Strategies	Elements of GE	Learning & Teaching Resources
<b>Introduction (10 minutes)</b>	<ol style="list-style-type: none"> <li>1. Teacher reviews Pre-lesson Worksheet and introduces the tasks in the lesson.</li> <li>2. Teacher asks students to present their answers on the Pre-lesson Worksheet.</li> </ol>			Pre-lesson Worksheet
<b>Fibonacci Sequence in Nature (15 minutes)</b>	<ol style="list-style-type: none"> <li>1. Lesson Worksheet Sets 1, 2, 3 are of different levels and are distributed to groups according to their Mathematical ability.</li> <li>2. Students study the scenario in Task 1 on the worksheets to write down the sequence. Teacher may provide hints to students if necessary.</li> </ol>	Ability Grouping	 	Lesson Worksheet
<b>Fibonacci Sequence and Golden Ratio (10 minutes)</b>	<ol style="list-style-type: none"> <li>1. Students investigate the ratio of successive terms in Fibonacci sequence by doing Task 2 and 3.</li> <li>2. Teacher may provide extra materials to groups that finish earlier.</li> </ol>	Ability Grouping	 	Lesson Worksheet Lesson Worksheet – Hint and Extra Materials
<b>Student Presentation (15 minutes)</b>	Three groups of students present their findings in Task 1, 2 and 3.	Presentation	 	Lesson Worksheet Lesson Worksheet – Hint and Extra Materials

Learning Focus (Time)	Activity / Content	Learning & Teaching Strategies	Elements of GE	Learning & Teaching Resources
<b>Exact Value of Golden Ratio (20 minutes)</b>	Students work in groups on Task 4 to find out the exact value of Golden Ratio using the quadratic formula or geometric construction.	Ability Grouping	 	Lesson Worksheet  Rulers and pairs of compasses
<b>Summary (5 minutes)</b>	Teacher gives a summary about the relation between Fibonacci sequence and Golden Ratio.			

### Extended Learning Activities

- Investigate on the use of Golden Ratio in design and architecture by doing Task 5 on the Lesson Worksheet. Students measure the lengths and check whether Golden Ratios exist in the logo or building.
- Finish the Extension Worksheet.

# Pre-lesson Worksheet

## Different Ratios

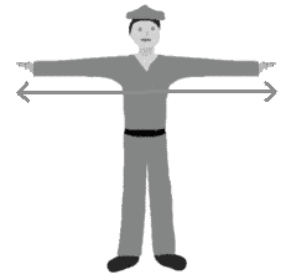
### 1. Human Body Ratio

Your arm span = \_\_\_\_\_ cm

Your height = \_\_\_\_\_ cm

What is the ratio of arm span to height?

Express your answer in the form  $n : 1$ .



### 2. Ratio of length to width in A-series paper

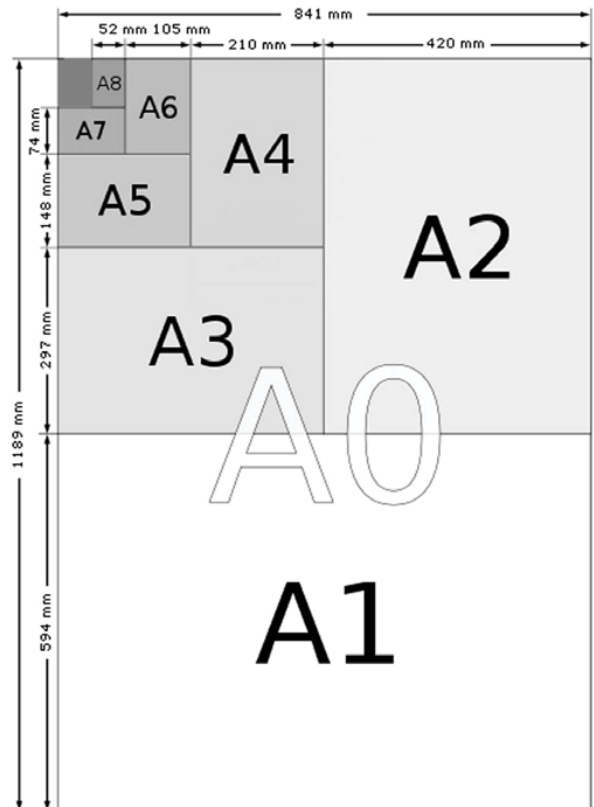
Express your answer in the form  $n : 1$ .

In **A0** paper,  
ratio of longer side to shorter side  $\approx$

In **A1** paper,  
ratio of longer side to shorter side  $\approx$

In **A2** paper,  
ratio of longer side to shorter side  $\approx$

In general, ratio of longer side to shorter side  $\approx$

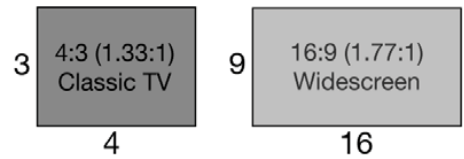


(<https://www.papersizes.org/a-series-full-sized-diagram.htm>)

## Pre-lesson Worksheet

### 3. Aspect Ratio of smart phone / television

*Aspect Ratio* refers to the width of a picture (or a screen) to its height and is most often expressed as two integer numbers separated by a colon ( $x:y$ ).

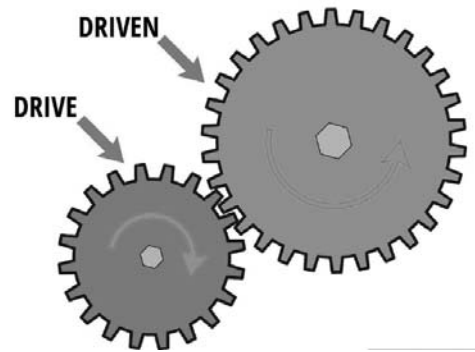


Find the height and width of a 19-inch TV screen to the nearest tenth of an inch. (The measure given is the length of the diagonal across the screen.)

- (a) A regular TV has an aspect ratio of 4 : 3;
- (b) A regular TV has an aspect ratio of 16 : 9.

### 4. Gear Ratio

*Gear ratio* is the ratio of the teeth of the driven gear to that of the drive gear.










- (a) If the drive gear is 20 teeth and the driven gear is 30 teeth, what the gear ratio would be?
- (b) In another word, if drive gear turns one time, how many times the driven gear turns?

# Lessons 1 -2

## Lesson Worksheet - Set 1

### Task 1 Flower petals

Picture		Name	Number of petals
		White Calla Lily	
		Euphorbia	
		Trillium	
		Wild rose	
		Clematis	
		Black-eyed Susan	
		Plantain	

## Lessons 1 -2

### Lesson Worksheet - Set 1

#### Task 2

Knowledge Review:  $T_1, T_2, T_3$  represent the 1<sup>st</sup> term, the 2<sup>nd</sup> term and the 3<sup>rd</sup> term of the sequence respectively.

1. List the number of petals (Task 1) as a sequence.

2. From the above sequence,

$$T_1 + T_2 =$$

$$T_2 + T_3 =$$

$$T_3 + T_4 =$$

$$T_4 + T_5 =$$

Using the above patterns,  $T_{n-1} + T_{n-2} =$

This sequence is called **Fibonacci Sequence**.

#### Task 3

1. Using the above Fibonacci sequence to give your answers correct to 4 significant figures,

$$\frac{T_2}{T_1} =$$

$$\frac{T_3}{T_2} =$$

$$\frac{T_4}{T_3} =$$

$$\frac{T_5}{T_4} =$$

$$\frac{T_6}{T_5} =$$

$$\frac{T_{11}}{T_{10}} =$$

$$\frac{T_{50}}{T_{49}} =$$

2. If we continue in this pattern, the ratio will approach the decimal number \_\_\_\_\_.

This value is approximate to the golden ratio.



# Lessons 1 -2

## Lesson Worksheet - Set 1

### Golden Rectangle

**Golden Rectangle** is a rectangle that can be cut into a square and a rectangle **similar to** the original one.

Figure 1 shows that  $ABCD$  is a **Golden Rectangle** such that  $FCDE$  is similar to  $ABCD$ .

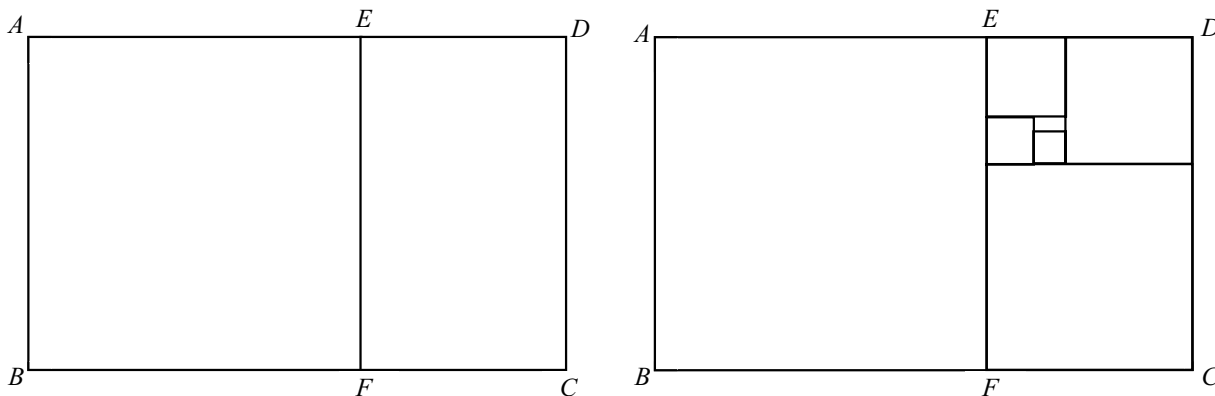
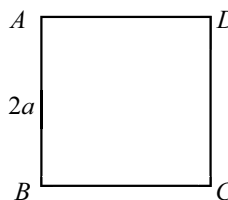


Figure 1

### Task 4 Exact value of Golden Ratio

Form Golden Rectangles from a square  $ABCD$  with side  $2a$ .



<p><b>Step 1</b>  <math>\rightarrow E</math> is the mid-point of <math>BC</math>  <math>\rightarrow</math> Join <math>ED</math></p>	<p><b>Step 2</b>                      (i) Extend <math>BC</math> to point <math>P</math>                      (ii) Use a compass to draw an arc from <math>D</math> (where <math>E</math> is the centre) to line <math>CP</math>, mark a "x" in the point of intersection and call this point <math>F</math></p>	<p><b>Step 3</b>                      (i) Draw a line which is parallel to <math>CD</math> and pass through <math>F</math>                      (ii) Extend <math>AD</math> to the above line until they meet at <math>G</math></p>

- Express  $ED$ ,  $BF$  and  $CF$  in terms of  $a$ .
- Are  $\frac{BF}{AB}$  and  $\frac{FG}{CF}$  equal? Explain briefly.

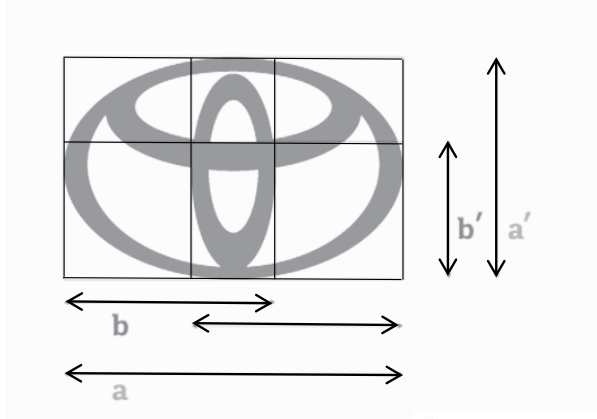
This value is the exact value of golden ratio.

# Lessons 1 -2

## Lesson Worksheet - Set 1

### Task 5 Golden Ratio in real life

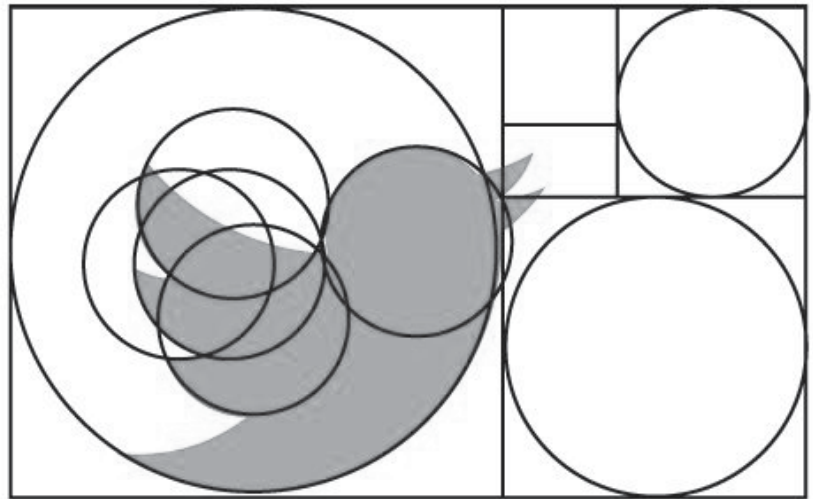
#### (I) Ratio in Design



By measurement,

$$\frac{a}{b} =$$

$$\frac{a'}{b'} =$$



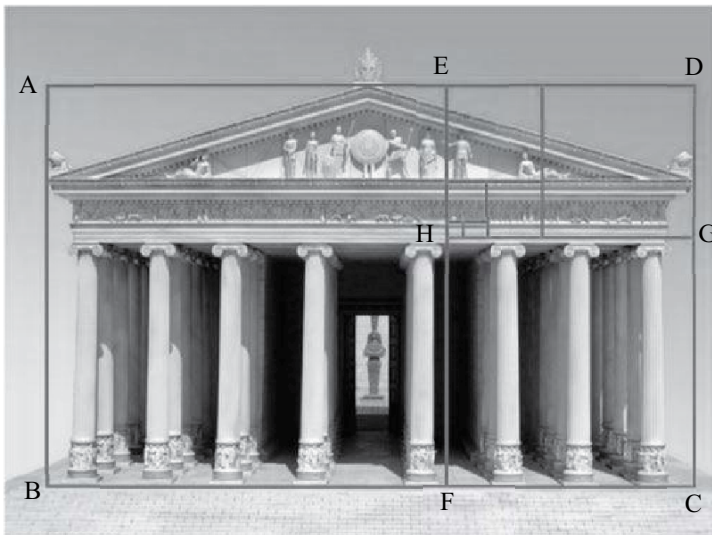
Let  $d_l$ ,  $d_m$  and  $d_s$  be the diameters of the largest circle, middle-sized circle and the smallest circle respectively.

$$\frac{d_l}{d_m} =$$

$$\frac{d_m}{d_s} =$$

Could the logo be designed with the golden ratio?

#### (II) Ratio in Architecture



1. The Parthenon in Athens.

$$\frac{BC}{AB} =$$

$$\frac{CD}{FC} =$$

$$\frac{DE}{GD} =$$

2. Some people claim that it is based on golden rectangles. What do you think?

## Lessons 1 -2

### Lesson Worksheet - Set 2

#### Task 1 Honeybees

In a colony of honeybees, there is a special female called the **queen**.

There are many **worker** bees who are female too but unlike the queen bee, they produce no eggs.

There are some **drone** bees who are male and do not work.

Males are produced by the queen's unfertilized eggs, so male bees only have a mother but no father!

All the females are produced when the queen has mated with a male and thus have two parents.

So female bees have 2 parents, a male and a female; whereas male bees have just one parent, a female.

Number of	parents	Grand-parents	Great grand-parents	Gt, gt grand-parents	Gt,gt,gt-grand-parents	Gt, gt,gt, gt-grand-parents
Male bees						
Female bees						

#### Task 2

Knowledge Review:  $T_1, T_2, T_3, T_4, \dots, T_n, \dots$  are the terms of sequence.

- List the number of parents (including grand-parents and etc) in male honeybees as a sequence.
- Predict the next two terms of the above sequence.  
Hence, find the recursive formula of the sequence.
- What's the type of the sequence?

## Lessons 1 -2

### Lesson Worksheet - Set 2

#### **Task 3**

1. Using the above sequence, find the ratio of each successive pair of numbers and give your answers correct to 4 significant figures.

$$\frac{T_2}{T_1} =$$

$$\frac{T_3}{T_2} =$$

2.  $\frac{T_n}{T_{n-1}} \approx$

This value is approximate to the golden ratio.

# Lessons 1 -2

## Lesson Worksheet - Set 2

### Golden Rectangle

**Golden Rectangle** is a rectangle that can be cut into a square and a rectangle **similar to** the original one. Figure 1 shows that  $ABCD$  is a **Golden Rectangle** such that  $FCDE$  is similar to  $ABCD$ .

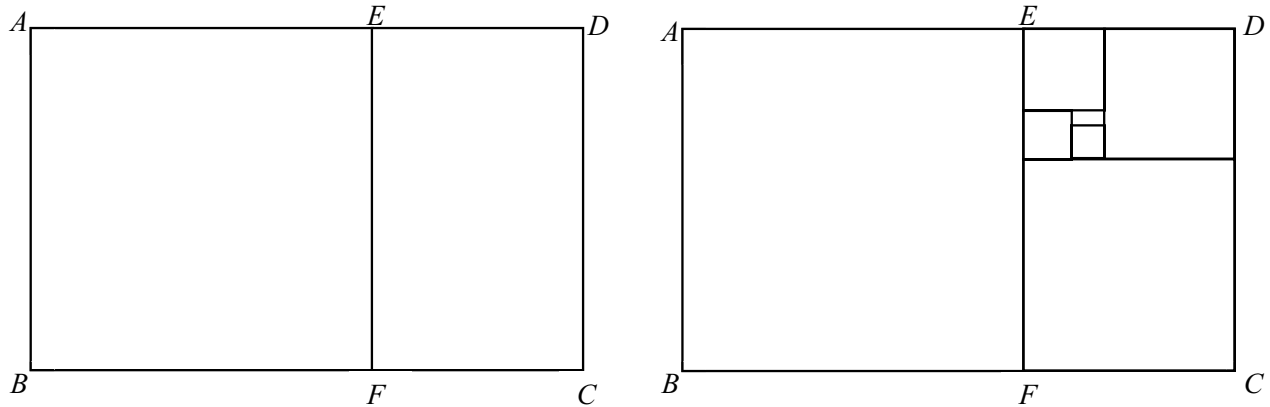
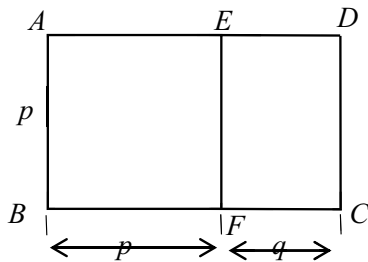


Figure 1

### Task 4 Exact value of Golden Ratio

The figure shows that  $ABCD$  is a **Golden Rectangle** such that  $FCDE$  is similar to  $ABCD$ .



Using  $\frac{BC}{AB} = \frac{CD}{FC}$  and let  $\varphi$  be  $\frac{p}{q}$

(i.e.  $\frac{1}{\varphi} = \frac{q}{p}$ ), **form** and **solve** an equation in  $\varphi$ .

### Useful information

For the equation  $a\varphi^2 + b\varphi + c = 0$ ,

$$\varphi = \frac{-b \pm \sqrt{b^2 - 4ac}}{2a}$$

Example

Solve  $2\varphi^2 - 5\varphi + 3 = 0$ .

$$2\varphi^2 - 5\varphi + 3 = 0$$

$$\varphi = \frac{-(-5) \pm \sqrt{(-5)^2 - 4(2)(3)}}{2(2)}$$

$$= \frac{5 \pm \sqrt{25 - 24}}{4}$$

$$= \frac{5 \pm \sqrt{1}}{4}$$

$$\varphi = \frac{5+1}{4} \quad \text{or} \quad \varphi = \frac{5-1}{4}$$

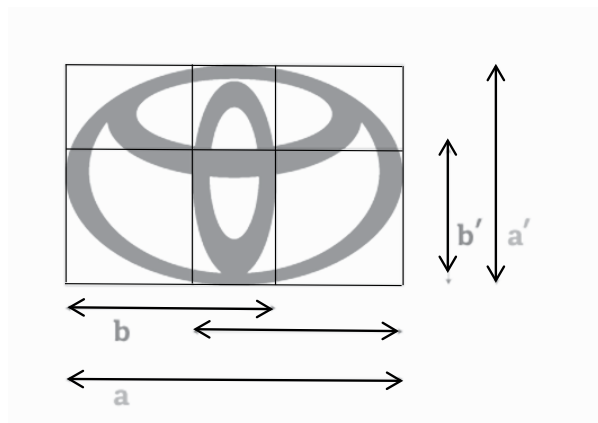
$$\varphi = \frac{3}{2} \quad \text{or} \quad \varphi = 1$$

# Lessons 1 -2

## Lesson Worksheet - Set 2

### Task 5 Golden Ratio in real life

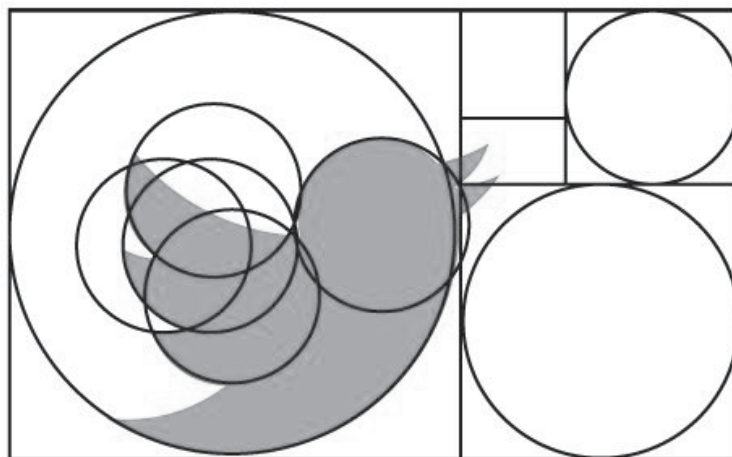
#### (I) Ratio in Design



By measurement,

$$\frac{a}{b} =$$

$$\frac{a'}{b'} =$$



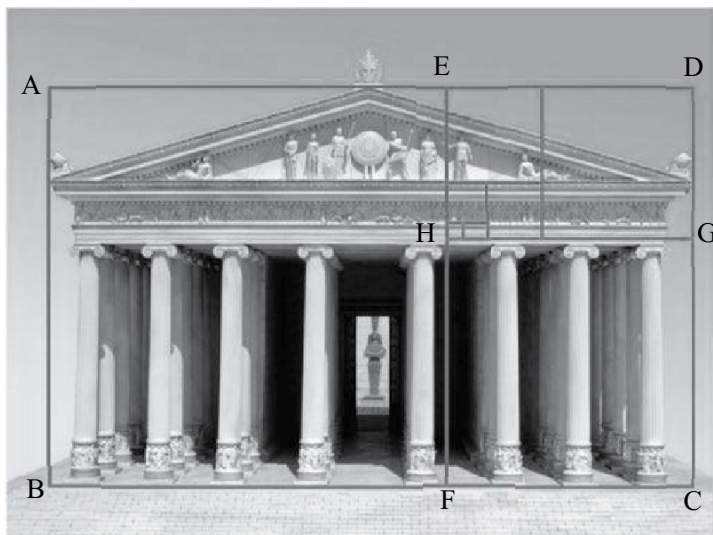
Let  $d_l, d_m$  and  $d_s$  be the diameters of the largest circle, middle-sized circle and the smallest circle respectively.

$$\frac{d_l}{d_m} =$$

$$\frac{d_m}{d_s} =$$

Could the logo be designed with the golden ratio?

#### (II) Ratio in Architecture



1. The Parthenon in Athens

$$\frac{BC}{AB} =$$

$$\frac{CD}{FC} =$$

$$\frac{DE}{GD} =$$

2. Some people claim that it is based on golden rectangles. What do you think?

## Lessons 1 -2

### Lesson Worksheet - Set 3

#### Task 1 Rabbits

Suppose a newly-born pair of rabbits, one male, one female, are put in a field. Rabbits are able to mate at the age of one month so that at the end of its second month, a female can produce another pair of rabbits. Suppose that the rabbits **never die** and that female **always** produces one new pair (one male, one female) **every month** from the second month onwards.

1. At the end of the first month, how many pair(s) will there be?
2. At the end of the second month, how many pair(s) will there be?
3. At the end of the third month, how many pair(s) will there be?
4. At the end of the fourth month, how many pair(s) will there be?
5. At the end of the fifth month, how many pair(s) will there be?
6. How many pairs will there be in one year?

#### Task 2

Knowledge Review:  $T_1, T_2, T_3, T_4, \dots, T_n, \dots$  are the terms of sequence.

1. Find the recursive formula of the sequence.
  
  
  
  
  
  
  
  
  
  
2. What's the type of the sequence?

## Lessons 1 -2

### Lesson Worksheet - Set 3

#### Task 3

1. Using the above sequence, find the ratio of each successive pair of numbers and give your answers correct to 4 significant figures if necessary.

2. 
$$\frac{T_n}{T_{n-1}} \approx$$

This value is approximate to the golden ratio.



## Lessons 1 -2

### Lesson Worksheet - Set 3

#### Golden Rectangle

**Golden Rectangle** is a rectangle that can be cut into a square and a rectangle **similar to** the original one.

Figure 1 shows that  $ABCD$  is a **Golden Rectangle** such that  $FCDE$  is similar to  $ABCD$ .

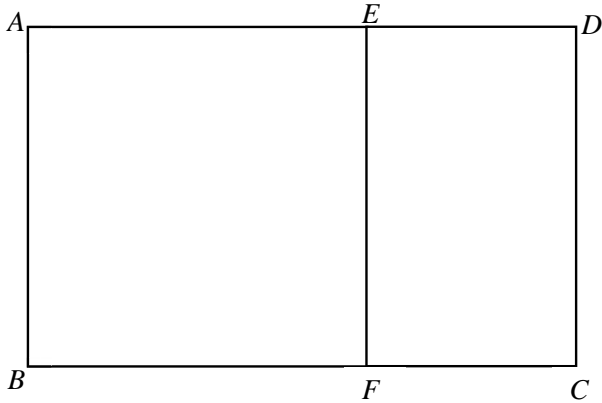
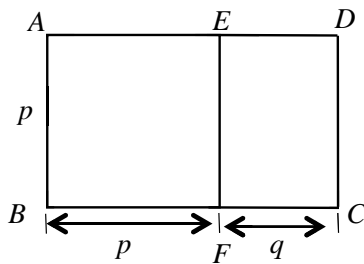


Figure 1

#### Task 4 Exact value of Golden Ratio

The figure shows that  $ABCD$  is a **Golden Rectangle** such that  $FCDE$  is similar to  $ABCD$ .



**Form** and **solve** an equation in  $\varphi$ , where  $\varphi = \frac{p}{q}$

#### Useful information

For the equation  $a\varphi^2 + b\varphi + c = 0$ ,

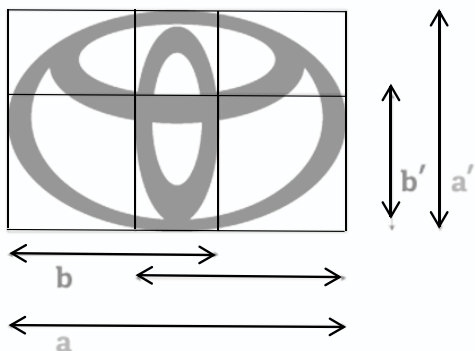
$$\varphi = \frac{-b \pm \sqrt{b^2 - 4ac}}{2a}$$

# Lessons 1 -2

## Lesson Worksheet - Set 3

### Task 5 Golden Ratio in real life

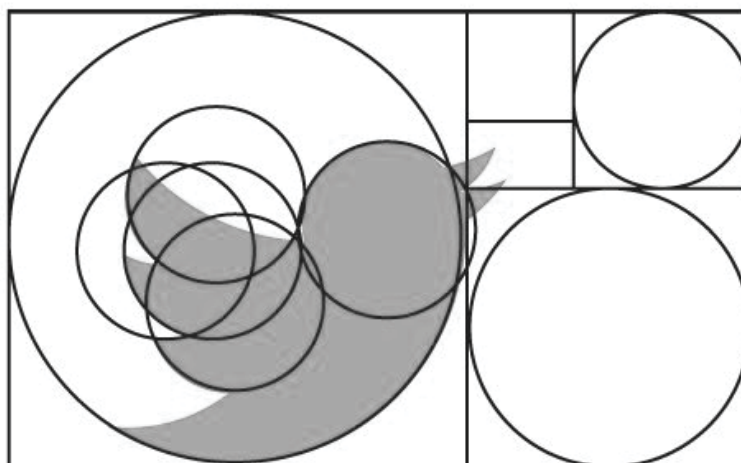
#### (I) Ratio in Design



By measurement,

$$\frac{a}{b} =$$

$$\frac{a'}{b'} =$$



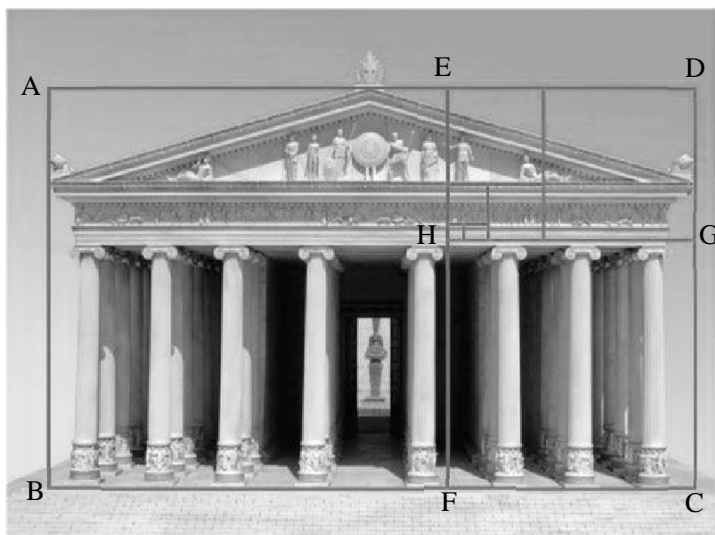
Let  $d_l, d_m$  and  $d_s$  be the diameters of the largest circle, middle-sized circle and the smallest circle respectively.

$$\frac{d_l}{d_m} =$$

$$\frac{d_m}{d_s} =$$

Could the logo have been designed with the golden ratio?

#### (II) Ratio in Architecture



1. The Parthenon in Athens,

$$\frac{BC}{AB} =$$

$$\frac{CD}{FC} =$$

$$\frac{DE}{GD} =$$

2. Some people claim that it is based on golden rectangles. What do you think?

# Lessons 1 -2

## Lesson Worksheet - Hints and Extra Materials

### Hints and Extra Materials

#### Worksheet Set 2 Task 1

### HONEY BEE

The situation mentioned is represented as the generations 1 to 3.  
Please complete the diagram below starting from generations 4 to 9.

Generation	Tree diagram	No. of grands
<b>9</b>		
<b>8</b>		
<b>7</b>		
<b>6</b>		
<b>5</b>		
<b>4</b>		
<b>3</b>		
<b>2</b>		
<b>1</b>		

M= Male bee  
F= Female bee





# Lessons 1 -2

## Lesson Worksheet - Hints and Extra Materials

### Worksheet Set 3 Task 1

#### RABBITS

The situation mentioned is represented as the time frames 1 to 3.  
Please complete the diagram below starting from the end of third month to eighth month.

Time	Tree diagram	No of pair(s) of rabbit
Beginning		
End of the first month		
End of the second month		
End of the third month		
End of the fourth month		
End of the fifth month		
End of the sixth month		
End of seventh month		
End of eighth month		

## Lessons 1 -2

### Lesson Worksheet - Hints and Extra Materials

#### Hints for Task 2

Consider the result of  $T_1+T_2$  and  $T_2+T_3$ .

Hence, try to deduce the recursive formula.

#### Hints for Task 5

$$\frac{a+b}{a} = 1 + \frac{b}{a}$$

#### Extra Materials 1



First 300 terms of Fibonacci sequence

#### Extra Materials 2



Video related to Fruit

# Lessons 1 -2

## Suggested Answers

### Suggested Answers

#### Pre-lesson Worksheet

- No specific answer and usually the ratio is approximately 1:1
- All the ratios are approximately 1.41:1
- (a) Height =11.4 inch, width =15.2 inch      (b) Height = 9.31 inch, width =16.66 inch
- (a) 3:2 (or 1.5:1)      (b) 0.67

#### Task 1 (Set 1) Flower petals

Name	Number of petals
White Calla Lily	<b>1</b>
Euphorbia	<b>2</b>
Trillium	<b>3</b>
Wild rose	<b>5</b>
Clematis	<b>8</b>
Black-eyed Susan	<b>13</b>
Plantain	<b>21</b>

#### Task 1 (Set 2) Honeybees

In a colony of honeybees there is a special female called the **queen**.

There are many **worker** bees who are female too but unlike the queen bee, they produce no eggs.

There are some **drone** bees who are male and do not work.

Males are produced by the queen's unfertilized eggs, so male bees only have a mother but no father!

All the females are produced when the queen has mated with a male and thus have two parents.

So female bees have 2 parents, a male and a female; whereas male bees have just one parent, a female.

Number of	parents	Grand-parents	Great grand-parents	Gt, gt grand-parents	Gt,gt,gt-grand-parents	Gt, gt,gt, gt-grand-parents
Male bees	<b>1</b>	<b>2</b>	<b>3</b>	<b>5</b>	<b>8</b>	<b>13</b>
Female bees	<b>2</b>	<b>3</b>	<b>5</b>	<b>8</b>	<b>13</b>	<b>21</b>

## Lessons 1 -2

### Suggested Answers

#### Task 2

Knowledge Review:  $T_1, T_2, T_3, T_4, \dots, T_n, \dots$  are the terms of sequence.

1. List the number of parents (including grand-parents and etc) in male honeybees as a sequence.

**1, 2, 3, 5, 8, 13, 21**

2. Predict the next two terms of the above sequence. **34, 55**

Hence, find the recursive formula of the sequence.

$$T_1 + T_2 = 1 + 2 = 3 = T_3$$

$$T_2 + T_3 = 2 + 3 = 5 = T_4$$

$$T_3 + T_4 = 3 + 5 = 8 = T_5$$

$$T_4 + T_5 = 8 + 13 = 21 = T_6 \quad \text{i.e. } T_{n-1} + T_{n-2} = T_n$$

3. What's the type of the sequence? **Fibonacci Sequence**

## Lessons 1 -2

### Suggested Answers

#### Task 1 (Set 3) Rabbits

Suppose a newly-born pair of rabbits, one male, one female, are put in a field. Rabbits are able to mate at the age of one month so that at the end of its second month a female can produce another pair of rabbits. Suppose that our rabbits **never die** and that the female **always** produces one new pair (one male, one female) **every month** from the second month onwards.

1. At the end of the first month, how many pair(s) will there be? **1**
2. At the end of the second month, how many pair(s) will there be? **1**
3. At the end of the third month, how many pair(s) will there be? **2**
4. At the end of the fourth month, how many pair(s) will there be? **3**
5. At the end of the fifth month, how many pair(s) will there be? **5**
6. How many pairs will there be in one year? **144**

**1, 1, 2, 3, 5, 8, 13, 21, 34, 55, 89, 144**

#### Task 2

Knowledge Review:  $T_1, T_2, T_3, T_4, \dots, T_n, \dots$  are the terms of sequence.

4. List the number of petals (Task 1) as a sequence.

**1, 2, 3, 5, 8, 13, 21**

5. From the above sequence,

$$T_1 + T_2 = 1 + 2 = 3 = T_3$$

$$T_2 + T_3 = 2 + 3 = 5 = T_4$$

$$T_3 + T_4 = 3 + 5 = 8 = T_5$$

$$T_4 + T_5 = 8 + 13 = 21 = T_6$$

Using the above patterns,  $T_{n-1} + T_{n-2} = T_n$

This sequence is called **Fibonacci Sequence**.



# Lessons 1 -2

## Suggested Answers

### Task 3

1. Using the above Fibonacci sequence to give your answers correct to 4 significant figures if necessary,

$$\frac{T_2}{T_1} = 2$$

$$\frac{T_3}{T_2} = 1.5$$

$$\frac{T_4}{T_3} = 1.667$$

$$\frac{T_5}{T_4} = 1.6$$

$$\frac{T_6}{T_5} = 1.625$$

$$\frac{T_{11}}{T_{10}} = 1.618$$

$$\frac{T_{50}}{T_{49}} = \frac{12586269025}{7778742049} \approx 1.618$$

2. If we continue in this pattern, the ratio will approach the decimal number **1.618**.

This value is approximate to the golden ratio.

### Golden Rectangle

**Golden Rectangle** is a rectangle that can be cut into a square and a rectangle similar to the original one.

Figure 1 shows that  $ABCD$  is a **Golden Rectangle** such that  $FCDE$  is similar to  $ABCD$ .

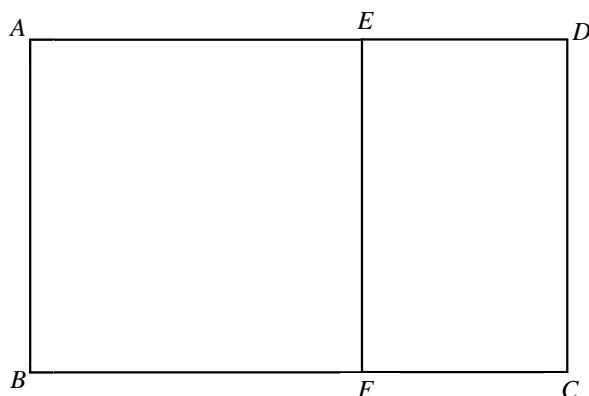
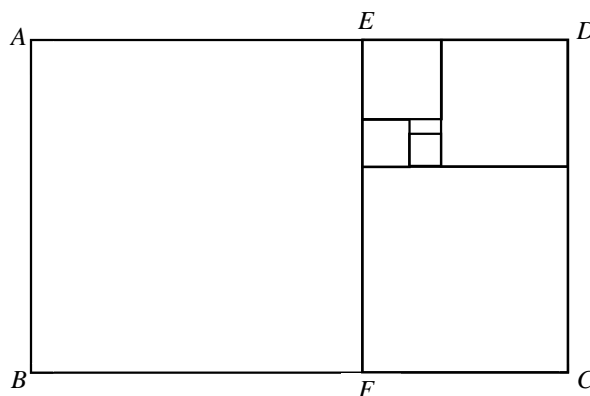


Figure 1



**Similar rectangles: ratios of corresponding lengths equal**

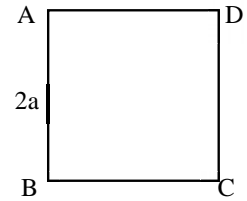
**Golden rectangle: the ratio of length to width is equal to golden ratio**

# Lessons 1 -2

## Suggested Answers

### Task 4 (Set 1) Exact value of Golden Ratio

Form Golden Rectangles from a square ABCD with side 2a.



<b>Step 1</b> →E is the mid-point of BC →Join ED	<b>Step 2</b> (i) Extend BC to point P (ii) Use a compass to draw an arc from D (where E is the centre) to line CP, mark a "x" in the point of intersection and call this point F	<b>Step 3</b> (i) Draw a line which is parallel to CD and passes through F (ii) Extend AD to the above line until they meet at G

(1) Express ED, BF and CF in terms of a.  $ED = \sqrt{5}a$ ,  $BF = (\sqrt{5} + 1)a$ ,  $CF = (\sqrt{5} - 1)a$

(2) Are  $\frac{BF}{AB}$  and  $\frac{FG}{CF}$  equal? Explain briefly.

$$\frac{BF}{AB} = \frac{(\sqrt{5} + 1)a}{2a} = \frac{\sqrt{5} + 1}{2}$$

$$\frac{FG}{CF} = \frac{2a}{(\sqrt{5} - 1)a} = \frac{2}{\sqrt{5} - 1} \cdot \frac{\sqrt{5} + 1}{\sqrt{5} + 1} = \frac{\sqrt{5} + 1}{2}$$

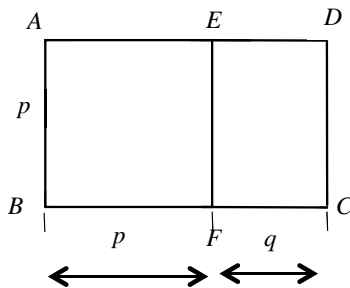
**Yes! This value is the exact value of golden ratio.**

# Lessons 1 -2

## Suggested Answers

### Task 4 (Set 2 and Set 3) Exact value of Golden Ratio

The figure shows that  $ABCD$  is a **Golden Rectangle** such that  $FCDE$  is similar to  $ABCD$ .



Using  $\frac{BC}{AB} = \frac{CD}{FC}$  and let  $\varphi$  be  $\frac{p}{q}$

(i.e.  $\frac{1}{\varphi} = \frac{q}{p}$ ), **form** and **solve** an equation in  $\varphi$ .

$$\frac{BC}{AB} = \frac{CD}{FC}$$

$$\frac{p+q}{p} = \frac{p}{q}$$

$$1 + \frac{q}{p} = \frac{p}{q} \rightarrow 1 + \frac{1}{\varphi} = \varphi$$

$$\varphi^2 - \varphi - 1 = 0$$

$$\varphi = \frac{-(-1) \pm \sqrt{(-1)^2 - 4(1)(-1)}}{2}$$

$$\varphi = \frac{1 \pm \sqrt{5}}{2} \quad \text{because } \varphi \text{ must positive}$$

$$\text{i.e. } \varphi = \frac{1 + \sqrt{5}}{2}$$

#### Useful information

For the equation  $a\varphi^2 + b\varphi + c = 0$ ,  $\varphi = \frac{-b \pm \sqrt{b^2 - 4ac}}{2a}$ .

Example

Solve  $2\varphi^2 - 5\varphi + 3 = 0$ .

$$2\varphi^2 - 5\varphi + 3 = 0$$

$$\varphi = \frac{-(-5) \pm \sqrt{(-5)^2 - 4(2)(3)}}{2(2)}$$

$$= \frac{5 \pm \sqrt{25 - 24}}{4}$$

$$= \frac{5 \pm \sqrt{1}}{4}$$

$$\varphi = \frac{5+1}{4} \quad \text{or} \quad \varphi = \frac{5-1}{4}$$

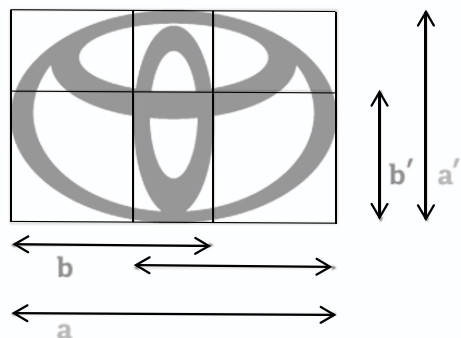
$$\varphi = \frac{3}{2} \quad \text{or} \quad \varphi = 1$$

## Lessons 1 -2

### Suggested Answers

#### Task 5 Golden Ratio in real life

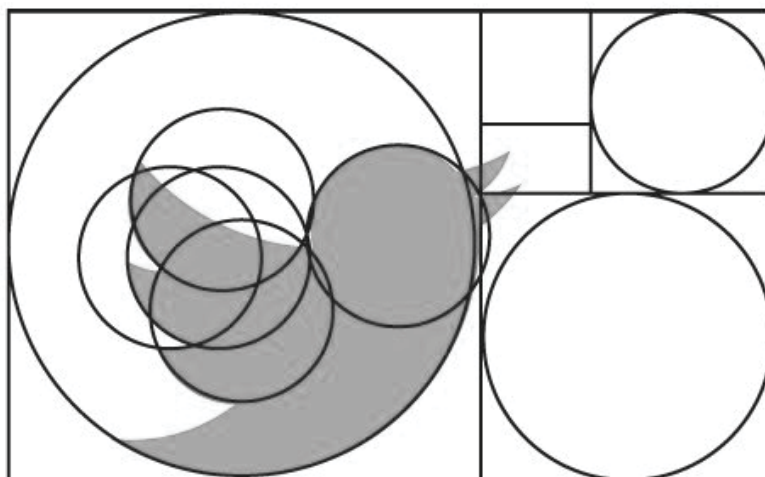
##### (I) Ratio in Design



By measurement,

$$\frac{a}{b} = \frac{5.1}{3.2} \approx 1.59$$

$$\frac{a'}{b'} = \frac{3.3}{2.1} \approx 1.57$$



Let  $d_l$ ,  $d_m$  and  $d_s$  be the diameters of the largest circle, middle-sized circle and the smallest circle respectively.

$$\frac{d_l}{d_m} = \frac{7.4}{4.5} \approx 1.644$$

$$\frac{d_m}{d_s} = \frac{4.6}{2.9} \approx 1.5862$$

Could the logo have been designed with the golden ratio?

**Yes, the ratios are close to the golden ratio**



##### (II) Ratio in Architecture

1. The Parthenon in Athens.

$$\frac{BC}{AB} = \frac{9.8}{6.1} \approx 1.6066$$

$$\frac{CD}{FC} = \frac{6.1}{3.8} \approx 1.6053$$

$$\frac{DE}{GD} = \frac{3.8}{2.3} \approx 1.6522$$

2. Some people claim that it is based on golden rectangles. What do you think?

**Yes, some ratios are close to golden ratio**

## Lessons 1 -2

### Extension Worksheet

#### (A) Investigation

(1) You are climbing a staircase. Each time you can climb either 1 or 2 steps.  
How many ways can you reach the 10<sup>th</sup> stair?

(2) Is the school logo designed in golden ratio?

If yes, explain your answer.

If no, design the school logo based on golden ratio.

#### (B) Extension

Prove that  $\sqrt{5}$  is an irrational number.

Assume  $\sqrt{5} = \frac{m}{n}$ , where  $m$  and  $n$  are positive numbers without common factors.

$$5 = \frac{m^2}{n^2}$$

$$m^2 = 5n^2 \dots (*)$$

i.e.  $m$  is a multiple of 5  $\rightarrow m = 5k$ , where  $k$  is positive number.

**From (\*),**  $(5k)^2 = 5n^2 \rightarrow n^2 = 5m^2$

i.e.  $n$  is a multiple of 5  $\rightarrow n = 5h$ , where  $h$  is positive number.

so,  $m$  and  $n$  are the multiples of 5, i.e.  $m$  and  $n$  have common factor 5, which contradict to the assumption.



$\sqrt{5}$  is an irrational number.

Knowing that  $\sqrt{5}$  is an irrational number, can you explain whether the exact value of Golden Ratio a rational or irrational number?

# 物有相似

適用級別：中三

課節（學習時數）：兩課節（80分鐘）

<b>學生已有知識</b>	相似三角形的比例
<b>學習目標</b>	<ul style="list-style-type: none"><li>- 學生能認識相似平面圖形對應邊長度與面積之間的關係</li><li>- 學生能認識相似立體圖形對應邊長度、對應面面積與體積之間的關係</li><li>- 學生理解和運用相似圖形對應邊長度、對應面面積與體積之間的關係來解題</li><li>- 學生對學習數學表現好奇心和維持興趣</li></ul>
<b>教與學策略</b>	適異性教學（按能力分組的探究式學習活動）、提問、分組討論、匯報
<b>資優教育推行模式</b>	第一層：校本全班式教學
<b>資優教育元素</b>	 高層次思維技巧  個人及社交能力

## 引言/背景

此課題是參考《數學教育學習領域課程指引（小一至中六）》而設計（課程發展議會，2017）。賽馬會「知優致優」計劃團隊及學校教師共同備課，依據該校中三級學生的特質和學習需要，在數學科透過探究式學習活動，推展資優教育校本全班式教學。該級別大部分學生均喜歡活動式的學習，而學習能力差異頗大，所以嘗試在課堂內加入多些分組討論和實作活動，以提升學生的學習動機，從而發揮學生的潛能。在設計課程和學與教策略方面，亦需要兼顧發揮資優 / 高能力學生的潛能，也要照顧學生的學習差異。

本示例以日常生活例子作切入，讓學生初步認識相似的概念，再透過探究式學習活動，讓學生利用實物來探究和判斷它們是否相似及解釋其原因，最後歸納出立體物件相似的概念和性質。課程亦滲入資優教育的元素，包括高層次思維技巧和個人及社交能力。

## 協作目標

本事例透過數學探究式教學，學生進行分組討論和實作活動，從而掌握平面圖形和立體圖形相似的概念。在學習過程中，學生的高層次思維技巧（包括解釋、判辨和歸納能力）和個人及社交能力得以培育，並讓具潛能的學生保持對數學的興趣、發揮所長。

## 基礎理論 / 理念架構

數學家常常在日常生活中，尋找現象的規律，並運用數學公式或理論表達，以嚴謹方式證明有關公式或理論為正確，可應用於一般情景，過程中需要運用很多重要能力，包括觀察、概括、數學符號運用、表達、抽象化、概念化、推理、歸納和演繹等。數學資優 / 高能力的學生有能力進行這類數學家探究活動，所以在課堂提供這些活動，發揮他們的才能。

### 1. 數學探究式學習

探究式學習活動包括開放式問題、分組討論、探索、實驗、動手做練習和利用應用程式進行探究。本事例以這類型活動為基礎，重視學生的參與和學習過程。學生在過程中多思維，有助加強他們的明辨性思考能力和解決問題能力。數學探究式教學重點在於讓學生能自主探索、找到問題的答案。

Siegel, Borasi, and Fonzi (1998) 提出四個數學探究階段：

學生已有知識	內容
準備與聚焦	這是探究的熱身階段，透過活動令學生有初步構想，探究跟主題相關的知識，挑戰學生的原有想法，激發學習興趣，最後聚焦在值得討論的議題上。
執行	決定出問題與探究的方向後，學生開始進行猜測、分析、推理與試驗等探究行為。經討論後獲得初步的結果。
綜合與溝通	按探究所得的結果，學生進行討論，相互辨證和論證，以得出最終的結果。學生必須學習如何闡述自己的想法與回應他人的意見。另一方面，教師在此階段中，可適時引導或幫助學生作結論。
評估與延伸	此階段的核心是「反思」，學生反思整個探究的過程，並確認與討論在探究過程中所獲得的數學知識。學生可以依據對探究結果的反思，形成新的探究問題，開啟下一個新的探究循環。

## 2. 適異性教學與資優教育三元素(高層次思維技巧，創造力和個人及社交能力) 可參考「前言」的相關理念。

### 課堂設計及編排

數學探究階段	課堂內容
準備與聚焦	藉由展示一些日常生活可接觸到的物件圖片，引起學生探究數學概念「相似」的動機。從學生的討論和分享，再引入課堂活動，讓學生用具體物件進行探究。
執行	學生按特質和能力進行分組活動，探究不同日常生活物品是否相似，當中可分成不同難度。高難度為探究不規則的立體物件是否相似，中難度為探究規則的立體物件，低難度則為探究規則的平面物件。
	學生開始探究過程，進行猜測、分析、推理與試驗等。
綜合與溝通	學生進行討論，解釋自己的想法和對組員提出的意見作回應，並嘗試歸納物件相似的概念。教師宜作適時引導或幫助學生作結論。各組亦向全班分享探究結果。
評估與延伸	學生反思整個探究過程，並確認數學上相似立體的性質，包括相似平面圖形對應邊長度與面積之間的關係，以及相似立體圖形對應邊長度、對應面面積與體積之間的關係。
	學生應用相關的理論，進行數學解題。

### 學與教策略

在基礎的數學課程，透過日常生活中的數學探究，讓學生探究周遭生活現象，尋找箇中規律，表達成數學公式或理論，並嘗試證明。學習過程中加入了不同解難策略和高階思維的鍛鍊，把重點放在發展學生解釋、判辨和歸納能力，而非強調學生的計算能力和速度。因此學生發揮的空間相當多，能發掘更多可探究的課題。另外，學生在組內的互動也能培養他人的個人及社交能力。



## 討論

學生在課堂的表現反映課程達至預期成效，綜合的結論和建議簡述如下：

### 1. 培育和發揮高層次思維技巧、個人及社交能力

#### 高層次思維技巧

教師善用提問激活學習氣氛，有層次地引導學生思考，刺激他們的思維。例子如下：

教師：這兩塊橡皮擦是否相似？  
 學生（甲）：是。  
 教師：為甚麼？  
 學生（甲）：憑感覺。  
 教師：在數學上相似的意義需要嚴謹的證明。如果我給一把尺你，你會做甚麼？  
 學生（乙）：量度橡皮擦的邊長。  
 教師：不同橡皮擦的邊長有甚麼關係？  
 學生（丙）：有特定的比例。  
 教師：對！這比例就是給我們判斷物件是否相似的參考。

從對話中可見，學生的思維從純粹直觀，發展到使用量度的概念，進而提升至抽象的比例概念，成功激發了學生不同層次的思維。

另外，探究式學習通過活動帶出學習要點，學生因直接參與，對有關的理論印象深刻，亦因在過程中經常動腦筋，而鍛練了敏捷的思考。從觀察所見，個別資優 / 高能力的學生深入思考，也向教師提出高層次的反問意見，例如「量度橢圓的長軸不準確，因為我們不知道它的中心點。」。

#### 個人及社交能力

在探究式學習的不同階段，均安排學生以分組形式進行活動，學生之間表現出良好互動的關係，投入討論和積極合作，以完成探究活動。

### 2. 實踐困難與改善建議






- 本示例的難點，是學生要探究出嚴謹的證明方法，部分學生用紙筆時，未能有系統地展示相似的關係。建議教師可容許他們口頭作答，這可給他們機會去思考相似的深層意義。
- 為照顧學生的學習多樣性，並提供機會給予資優 / 高能力的學生發揮潛能，教師可依據學生的特質及需要進行適異性教學。注意說明分組模式時，也要避免令學生有被負面標籤的感覺。

## 總結

按照學生的特質和能力進行適異性教學的探究式學習活動，能照顧全班學生的學習差異，亦能給與資優 / 高能力學生具挑戰性的學習經歷，以發揮他們的潛能。

## 課節一至二

### 教學活動

學習重點 (時間)	活動內容	教學策略	資優教育元素	學與教資源
透過日常生活例子，認識相似圖形的概念 (20分鐘)	<ol style="list-style-type: none"><li>學生通過課堂工作紙1上的日常生活例子，討論相似的概念。</li><li>學生分享討論的結果。</li></ol>	分組討論	 	課堂工作紙1
探討日常生活物品是否相似 (30分鐘)	<ol style="list-style-type: none"><li>學生按能力進行分組活動，運用相似的概念探討日常生活物品是否相似，各組難度不一。<ul style="list-style-type: none"><li>- 高難度：不規則的立體物件</li><li>- 中難度：規則的立體物件</li><li>- 低難度：規則的平面物件</li></ul></li><li>學生綜合和分享探究的結果。</li></ol>	按能力分組進行活動  匯報	 	課堂工作紙2  日常生活物品
判斷兩個圖形是否相似 (30分鐘)	<ol style="list-style-type: none"><li>學生應用所學在數學解難的題目上。</li><li>學生按自己的能力完成不同深度的題目。</li><li>歸納相似平面及立體的概念和性質。</li></ol>	提問		課堂工作紙3及4

#### 延伸學習活動

學生運用所學，尋找日常生活中更多相似的例子，並在往後的課堂分享。

# 課節一至二

## 課堂工作紙 1

### 物有相似

1. 在日常生活中，有很多東西令我們感覺相似。

下列那些事例是符合**數學上相似的定義**? 並請說明原因。

例子	相似嗎?	原因
A. 		
B. 		
C. 		
D. 		
E. 		

2. 根據題 1，試說明數學上，甚麼是「相似」?

---



---



---



---

## 課節一至二

### 課堂工作紙 1

#### 參考答案 / 指引

這部分旨在引起學生的動機，教師可先讓學生憑直觀判斷物件是否相似，然後再要求他們寫出直觀判斷時，會觀察甚麼，例如會否觀察長度、角度等，最後再引導學生使用長度、角度、比例等數學概念加以解釋，並嘗試寫出數學上相似的定義。

中學數學課程中並未嚴格寫出立體物件相似的定義，教師可參考以下方面說明相似的概念：

#### (1) 形狀

如兩立體有不同邊數、面數，則一定不會相似

如兩立體都是三角柱體，該對應的三角形要相似，否則立體也不會相似

#### (2) 長度

如兩個立體相似，則對應邊長必需成比例

#### (3) 角度

如兩個立體相似，則對應角度必需相等

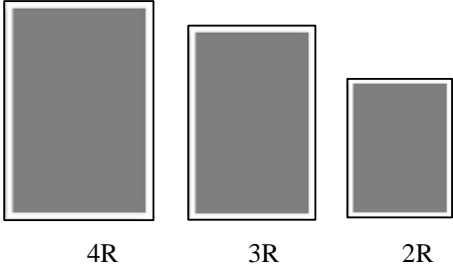
# 課節一至二

## 課堂工作紙 2

### 物有相似

分組活動

請每組就分發的物件，判斷是否相似，並說明相似的原因。

例子	相似嗎？	原因
A. 長方形（相片）  4R      3R      2R		
B. 六角柱體（零食包裝盒）		
C. 三角柱體（零食包裝盒）		
D. 正方體（扭計骰）		
E. 球體（桌球、乒乓球）		
F. 不規則形狀（文具）		

## 課節一至二

### 課堂工作紙2

參考答案/指引

A. 長方形

- 量度長方形邊長，計算並指出對應邊長是否成比例
- 答案視乎真實物件

B. 六角柱體

- 判斷柱體的底是否皆為正六邊形
- 量度六邊形的邊長和柱體的高度，計算並指出對應邊長是否成比例
- 答案視乎真實物件

C. 三角柱體

- 判斷柱體的底(三角形)是否為相似三角形
- 量度三角形的邊長和柱體的高度，計算並指出對應邊長是否成比例
- 答案視乎真實物件

D. 正方體

- 答案為相似，可引導學生指出所有正方體皆相似

E. 球體

- 答案為相似，可引導學生指出所有球體皆相似

F. 不規則形狀（文具）

- 答案視乎真實物件
- 可引導學生從形狀、長度、角度等方向解釋

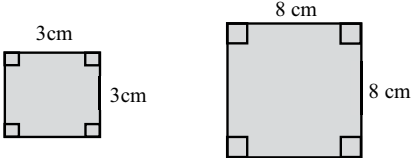
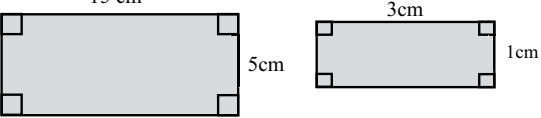
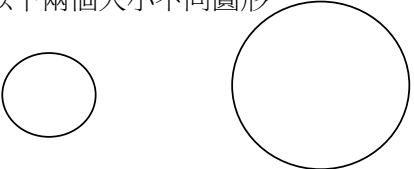
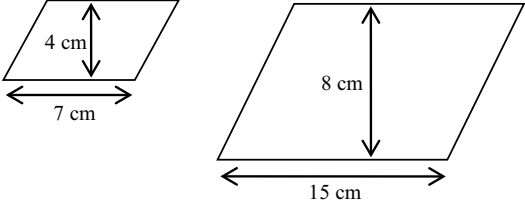
# 課節一至二

## 課堂工作紙 3

### 物有相似

#### 平面

1. 以(a)及(b)為例子，判斷(c)至(f)的圖形是否相似，並列出原因。

<p>(a) 以下兩個大小不同的正方形</p> <div style="text-align: center;">  </div> <p><input type="checkbox"/> 不相似，因為：_____</p> <p><input checked="" type="checkbox"/> 相似，因為：<u>圖形一樣，以上兩個正方形四邊成比例</u></p> <p>● 是否能推論所有大小不同的正方形也是相似？  <input checked="" type="checkbox"/> 是                      <input type="checkbox"/> 否</p> <p>因為：<u>正方形的四邊等長，且 4 個內角都是 <math>90^\circ</math>，所以任意兩個正方形必定成比例關係。</u></p>	<p>(b) 以下兩個大小不同的長方形</p> <div style="text-align: center;">  </div> <p><input type="checkbox"/> 不相似，因為：_____</p> <p><input checked="" type="checkbox"/> 相似，因為：<u>圖形一樣，以上大長方形與小長方形的長及闊的比均為 5。</u></p> <p>● 是否能推論所有大小不同的長方形也是相似？  <input type="checkbox"/> 是                      <input checked="" type="checkbox"/> 否</p> <p>因為：<u>長方形的四個內角為 <math>90^\circ</math>，但是邊長不一定成比例，例如一個長 10cm 寬 5cm 的長方形，和一個長 10cm 寬 7cm 的長方形就不成比例。</u></p>
<p>(c) 以下兩個大小不同圓形</p> <div style="text-align: center;">  </div> <p><input type="checkbox"/> 不相似，因為：_____</p> <p><input type="checkbox"/> 相似，因為：_____</p> <p>● 是否能推論所有大小不同的圓形也是相似？  <input type="checkbox"/> 是                      <input type="checkbox"/> 否</p> <p>因為：_____</p> <p>_____</p> <p>_____</p>	<p>(d) 以下兩個大小不同的平行四邊形</p> <div style="text-align: center;">  </div> <p><input type="checkbox"/> 不相似，因為：_____</p> <p><input type="checkbox"/> 相似，因為：_____</p> <p>● 是否能推論所有大小不同的平行四邊形也是相似？  <input type="checkbox"/> 是                      <input type="checkbox"/> 否</p> <p>因為：_____</p> <p>_____</p> <p>_____</p>

# 課節一至二

## 課堂工作紙3

(a) 以下三個大小不同的直角三角形

不相似，因為：\_\_\_\_\_

相似，因為：\_\_\_\_\_

● 是否能推論所有大小不同的直角三角形也是相似？  
 是                       否  
 因為：\_\_\_\_\_

(b) 以下兩個大小不同的等邊三角形

不相似，因為：\_\_\_\_\_

相似，因為：\_\_\_\_\_

● 是否能推論所有大小不同的等邊三角形也是相似？  
 是                       否  
 因為：\_\_\_\_\_

### 2. 試完成下表

相似平面圖形	對應邊(或線段)的長度的比	面積的比
正方形 	$\frac{l_1}{l_2} = \frac{ka}{a} = k$	$\frac{A_1}{A_2} = \frac{(ka)(ka)}{(a)(a)} = k^2$
三角形 	$\frac{l_1}{l_2} = \frac{(\quad)}{(\quad)} =$	$\frac{A_1}{A_2} = \frac{(\quad)}{(\quad)} =$



## 課節一至二

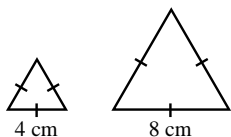
### 課堂工作紙3

結論：

若兩個相似平面圖形的一對對應邊長度是  $l_1$  和  $l_2$ ，而它們的面積分別是  $A_1$  和  $A_2$ ，則  $\frac{A_1}{A_2} = \left(\frac{l_1}{l_2}\right)^2$ 。

#### 教學例題 1

圖中顯示兩個邊長分別為 4 cm 和 8 cm 的等邊三角形。若較大的等邊三角形的面積是  $28 \text{ cm}^2$ ，求較小的等邊三角形的面積。



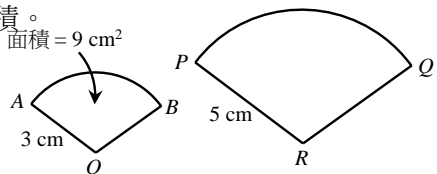
解

$$\frac{\text{較小的三角形的面積}}{28 \text{ cm}^2} = \left(\frac{4 \text{ cm}}{8 \text{ cm}}\right)^2$$
$$= \frac{1}{4}$$

$$\therefore \text{較小的三角形的面積} = \frac{1}{4} \times 28 \text{ cm}^2$$
$$= \underline{7 \text{ cm}^2}$$

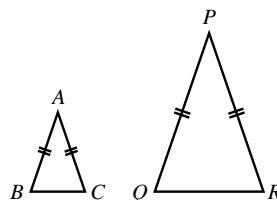
#### 即時練習 1.2

圖中顯示兩個相似扇形  $AOB$  和  $PRQ$ 。扇形  $AOB$  和  $PRQ$  的半徑分別是 3 cm 和 5 cm。若扇形  $AOB$  的面積是  $9 \text{ cm}^2$ ，求扇形  $PRQ$  的面積。



#### 即時練習 1.1

圖中顯示兩個相似等腰三角形  $ABC$  和  $PQR$ 。它們的周界分別是 8 cm 和 16 cm。若  $\triangle PQR$  的面積是  $11.2 \text{ cm}^2$ ，求  $\triangle ABC$  的面積。



#### 即時練習 1.3

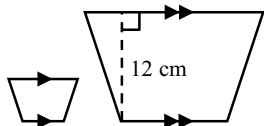
已知兩個等邊三角形的邊長之比是 2:5。若小三角形的面積是  $12 \text{ cm}^2$ ，求大三角形的面積。

## 課節一至二

### 課堂工作紙 3

#### 教學例題 2

圖中顯示兩個相似梯形。兩個梯形的面積分別是  $16 \text{ cm}^2$  和  $144 \text{ cm}^2$ 。若較大的梯形的高是  $12 \text{ cm}$ ，求較小的梯形的高。



解

設較小的梯形的高為  $h \text{ cm}$ 。

$$\left(\frac{h \text{ cm}}{12 \text{ cm}}\right)^2 = \frac{16 \text{ cm}^2}{144 \text{ cm}^2}$$

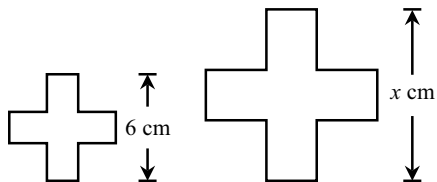
$$\frac{h}{12} = \frac{4}{12}$$

$$h = 4$$

$\therefore$  較小的梯形的高是  $4 \text{ cm}$ 。

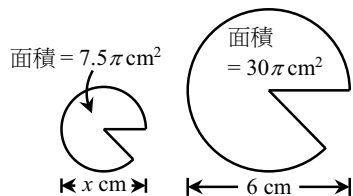
#### 即時練習 2.2

圖中顯示兩個相似平面圖形。兩個圖形的面積分別是  $16 \text{ cm}^2$  和  $36 \text{ cm}^2$ 。求  $x$  的值。



#### 即時練習 2.1

圖中顯示兩個相似平面圖形。兩個圖形的面積分別是  $7.5\pi \text{ cm}^2$  和  $30\pi \text{ cm}^2$ 。求  $x$  的值。



#### 即時練習 2.3

已知兩個正六邊形的面積之比是  $25 : 9$ 。若小六邊形的邊長為  $21 \text{ cm}$ ，求大六邊形的邊長。

## 課節一至二

### 課堂工作紙 3

參考答案/指引：

1(c) 相似，所有圓形也相似

1(d) 不相似，對應邊長比例： $\frac{4}{8} = \frac{1}{2}$  與  $\frac{7}{15}$  不相等，不是所有平行四邊形也相似

1(e) 左邊兩個三角形相似，右邊的與另外兩個不相似

左邊兩個三角形兩邊比為皆為  $\frac{2}{3}$ ，右邊的三角形則為  $\frac{3}{4}$

不是所有直角三角形也相似

1(f) 答案視乎真實量度出的長度

即時練習 1.1            2.8 cm<sup>2</sup>

即時練習 1.2            25 cm<sup>2</sup>

即時練習 1.3            75 cm<sup>2</sup>

即時練習 2.1            3

即時練習 2.2            9

即時練習 2.3            35

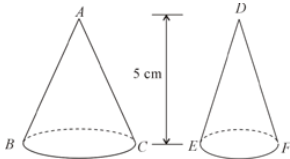
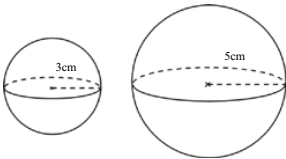
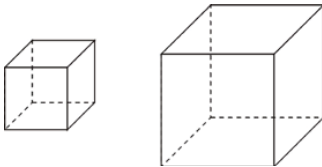
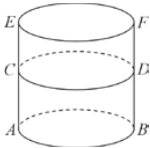
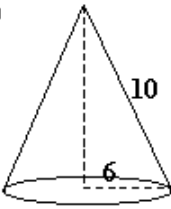
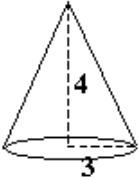
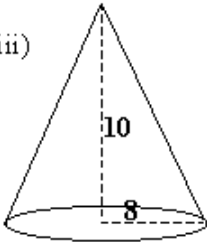
# 課節一至二

## 課堂工作紙 4

### 物有相似

#### 立體

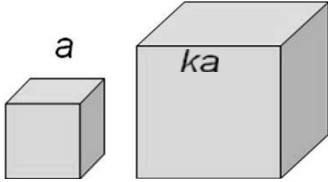
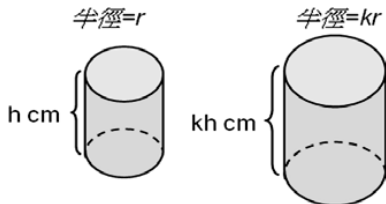
1. 以(a)為例子，判斷(c)至(e)的立體圖形是否相似，並列出原因。

<p>(a) 直立圓錐 <math>ABC</math> 及 <math>DEF</math></p>  <p><input type="checkbox"/> 相似，因為：_____</p> <p>_____</p> <p><input checked="" type="checkbox"/> 不相似，因為：<u>高度長度比是 1:1，但半徑長度比不是 1:1。</u></p>	<p>(b) 兩個大小不同的球體</p>  <p><input checked="" type="checkbox"/> 相似，因為：_____</p> <p>_____</p> <p><input type="checkbox"/> 不相似，因為：_____</p> <p>_____</p>
<p>(c) 兩個大小不同的正方體</p>  <p><input type="checkbox"/> 相似，因為：_____</p> <p>_____</p> <p><input type="checkbox"/> 不相似，因為：_____</p> <p>_____</p>	<p>(d) 圓柱 <math>ABDC</math> 及 <math>ABFE</math></p>  <p><input type="checkbox"/> 相似，因為：_____</p> <p>_____</p> <p><input type="checkbox"/> 不相似，因為：_____</p> <p>_____</p>
<p>(e)</p> <div style="display: flex; justify-content: space-around; align-items: flex-start;"> <div style="text-align: center;"> <p>(i)</p>  </div> <div style="text-align: center;"> <p>(ii)</p>  </div> <div style="text-align: center;"> <p>(iii)</p>  </div> </div> <p><input type="checkbox"/> 相似，因為：_____</p> <p><input type="checkbox"/> 不相似，因為：_____</p>	

## 課節一至二

### 課堂工作紙 4

2. 試完成下表

相似立體圖形: 正方體		
		
對應邊(或線段)的長度的比	底面積的比	體積的比
$\frac{l_1}{l_2} = \frac{ka}{a} = \underline{\hspace{2cm}}$	$\frac{A_1}{A_2} = \frac{(ka)(ka)}{(a)(a)} = \underline{\hspace{2cm}}$	$\frac{V_1}{V_2} = \frac{(\quad)}{(\quad)} = \underline{\hspace{2cm}}$
相似立體圖形: 圓柱		
		
對應邊(或線段)的長度的比	底面積的比	體積的比
$\frac{l_1}{l_2} = \frac{kr}{r} = \underline{\hspace{2cm}}$ $\frac{l_1}{l_2} = \frac{kh}{h} = \underline{\hspace{2cm}}$	$\frac{A_1}{A_2} = \frac{(\quad)}{(\quad)} = \underline{\hspace{2cm}}$	$\frac{V_1}{V_2} = \frac{(\quad)}{(\quad)} = \underline{\hspace{2cm}}$

結論：

若兩個相似立體圖形的一對對應邊長度是  $l_1$  和  $l_2$ ，而它們的面積分別是  $A_1$  和  $A_2$ ，則  $\frac{A_1}{A_2} = \left(\frac{\quad}{\quad}\right)^{\quad}$ 。

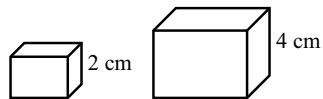
若兩個相似立體圖形的一對對應邊長度是  $l_1$  和  $l_2$ ，而它們的體積分別是  $V_1$  和  $V_2$ ，則  $\frac{V_1}{V_2} = \left(\frac{\quad}{\quad}\right)^{\quad}$ 。

## 課節一至二

### 課堂工作紙 4

#### 教學例題 3

圖中顯示兩個相似長方體。其中一個高 2 cm，而另一個高 4 cm。若較小的長方體的總表面面積是  $52 \text{ cm}^2$ ，求較大的長方體的總表面面積。



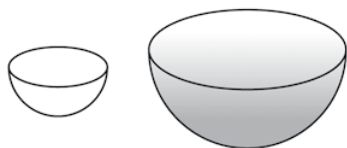
解

$$\frac{\text{較大的長方體的總表面面積}}{52 \text{ cm}^2} = \left(\frac{4 \text{ cm}}{2 \text{ cm}}\right)^2 = 4$$

$$\begin{aligned} \therefore \text{較大的長方體的總表面面積} \\ &= 4 \times 52 \text{ cm}^2 \\ &= \underline{208 \text{ cm}^2} \end{aligned}$$

#### 即時練習 3.2

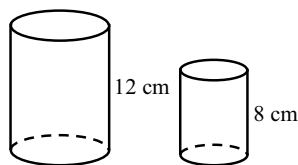
圖中所示為兩個呈半球形的碗，其中大碗盛滿了水。已知大碗內的水可盛滿 8 個小碗。



- 求小碗與大碗的直徑之比。
- 若大碗的曲面面積是  $40 \text{ cm}^2$ ，求小碗的曲面面積。

#### 即時練習 3.1

圖中顯示兩個相似圓柱。其中一個高 12 cm，而另一個高 8 cm。若較小的圓柱的總表面面積是  $40\pi \text{ cm}^2$ ，以  $\pi$  表示較大的圓柱的總表面面積。



#### 即時練習 3.3

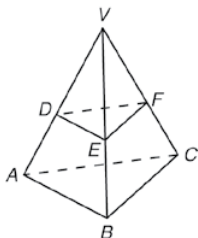
現有兩個相似的玻璃瓶。已知小玻璃瓶和大玻璃瓶的總表面面積分別為  $504 \text{ cm}^2$  和  $1400 \text{ cm}^2$ 。

- 求小玻璃瓶與大玻璃瓶的高之比。
- 若大玻璃瓶的容量為 1.25 L，求小玻璃瓶的容量。

## 課節一至二

### 課堂工作紙 4

$$VE : EB = 3 : 2。$$



- (a) 求棱錐  $VDEF$  與棱錐  $VABC$  的體積之比。  
 (b) 求  $\triangle VDE$  與四邊形  $ABED$  的面積之比。

解

(a)

$$\begin{aligned} \frac{\text{棱錐 } VDEF \text{ 的體積}}{\text{棱錐 } VABC \text{ 的體積}} &= \left(\frac{VE}{VB}\right)^3 \\ &= \left(\frac{3}{3+2}\right)^3 \\ &= \left(\frac{3}{5}\right)^3 \\ &= \frac{27}{125} \end{aligned}$$

$\therefore$  棱錐  $VDEF$  與棱錐  $VABC$  的體積之比是  $27 : 125$ 。

- (b) 設  $\triangle VDE$  和  $\triangle VAB$  的面積分別為  $A_1$  和  $A_2$ 。

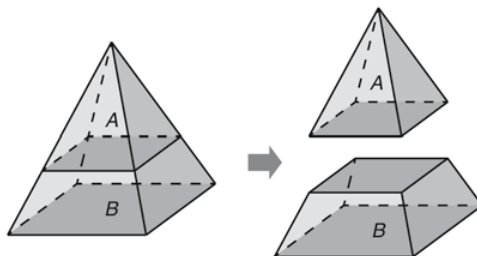
$$\begin{aligned} \frac{A_1}{A_2} &= \left(\frac{VE}{VB}\right)^2 \\ &= \left(\frac{3}{5}\right)^2 \\ &= \frac{9}{25} \end{aligned}$$

$$\therefore A_1 = \frac{9}{25} A_2$$

$$\begin{aligned} \frac{\square VDE \text{ 的面積}}{\text{四邊形 } ABED \text{ 的面積}} &= \frac{A_1}{A_2 - A_1} \\ &= \frac{\frac{9}{25} A_2}{A_2 - \frac{9}{25} A_2} \\ &= \frac{\frac{9}{25} A_2}{\frac{16}{25} A_2} \\ &= \frac{9}{16} \end{aligned}$$

$\therefore \triangle VDE$  與四邊形  $ABED$  的面積之比是  $9 : 16$ 。

開，得出小棱錐  $A$  和平截頭體  $B$ 。若棱錐  $A$  和平截頭體  $B$  的高分別為  $6\text{ cm}$  和  $3\text{ cm}$ ，求棱錐  $A$  與平截頭體  $B$  的所有側面面積之比。



解

## 課節一至二

### 課堂工作紙 4

參考答案/指引：

1(b) 相似，教師可詳細解釋為何所有球體都是相似，或可留待課後延伸討論。

1(c) 相似，教師可詳細解釋為何所有正方體都是相似，或可留待課後延伸討論。

1(d) 不相似，兩圓柱的底相同，但高度不同，對應邊長不成比例。

1(e) 不相似，計算高與底的比可等出三個不同比例 [(i)  $\frac{5}{3}$  (ii)  $\frac{4}{3}$  (iii)  $\frac{5}{4}$ ]

即時練習 3.1  $90\pi \text{ cm}^2$

即時練習 3.2 (a) 1:2 (b)  $10 \text{ cm}^2$

即時練習 3.3 (a) 3:5 (b) 0.27 L

即時練習 4 4:5



數學科 第二層

校本抽離式  
計劃

Mathematics Level 2

School-based  
Pull-out Programme

# Extension of Pythagoras' Theorem

**Grade: Secondary 2 or 3**

**No. of Lessons (Learning Time): 3 Lessons (60 -90 minutes for each unit)**

<b>Operation Mode of Gifted Education</b>	Level 2: School-based Pull-out Programme
<b>Target Students</b>	<ul style="list-style-type: none"><li>- S2 or S3 Students having outstanding or above-average performance and strong interest in Mathematics</li><li>- Students who are gifted in Mathematics</li><li>- High-potential students with great with high initiatives in learning Mathematics and good foundations in Mathematics and reasoning skills, as observed by teachers</li></ul>

## Foreword / Background

Through daily observation, some students of the Project School have been found to have strong interest in mathematics. They are keen on answering questions and sharing their ideas in the lesson. They are also enthusiastic about attempting challenging questions and may even continue the discussion about questions at recess and lunchtime. However, without the extended training that suits these students, their learning progress may be limited to textbook content, the examination syllabus and the regular lessons. They need systematic training that brings insight into the subject and sustains their learning interest. This coincides with the rationale of the Level 2 implementation of school-based gifted education, which is to conduct a pull-out programme to nurture talents of students (Education Bureau, n.d.).

Pythagoras' Theorem is a topic covered in the S2 mathematics curriculum. It is an important and well-known theorem in geometry. Some areas of mathematics such as number theory and trigonometry have close relations with the theorem, so it can be a starting point to widen students' exposure to and understanding of mathematics, and to nurture their thinking and generic skills.

## Objectives of Collaboration

Learning and teaching in regular classrooms are usually restricted by pre-defined learning content and limited lesson time. In contrast, a pull-out programme can have more flexibility to incorporate learning activities that train students to think like a mathematician. This pull-out programme aims to focus on process skills and to promote self-learning in mathematics. The learning units in this programme highlight different inquiry and problem solving skills in mathematics, such as

generalization, observing patterns and making judgements by proof or counter-example. These skills are essentials in learning advanced mathematics and can pave roads for further self-learning. After the lesson, students are expected to develop a mindset that learning of mathematics does not end at calculation, but is extended to exploration or review of knowledge from different perspectives.

## Student Selection Criteria and Procedures

The pull-out programme targeted on S2 or S3 students having outstanding or above-average performance and strong interest in mathematics, with proper selection criteria and procedures.

### 1. Mathematics examination results

The programme coordinator first listed some targeted students according to previous mathematics examination results to select the high achievers and above-average students.

### 2. Teachers' nomination

Based on the list, mathematics teachers of each class commented on students' learning attitude and their interest in mathematics. Teachers also suggested other students with strong interest in mathematics but not listed. The following shows some possible characteristics of students gifted in Mathematics according to EdB (n.d.). Teachers can refer to these characteristics when looking for target students. They:

- Learn faster than ordinary students
- Demonstrate high levels of comprehension power in mathematics
- Are interested in figures and signs
- Enjoy abstract thinking
- Manipulate mathematical concepts easily
- Feel bored to learn by means of memorization or drilling
- Are able to find shortcuts to solve problems
- Are able to adopt flexible and multiple approaches to solve mathematical problems

### 3. Students' self-nomination

Students who are interested could also make self-nomination.

## Theoretical Framework

According to VanTassel-Baska and Stambaugh (2006), a gifted programme must be designed to offer deep content learning. It should include a major emphasis on process skills such as problem solving, critical thinking and research skills. When designing a curriculum for the gifted, educators can apply the following features of differentiation to the content areas, namely acceleration, complexity, depth, challenge, creativity, and abstractness.

Features	Application to Content Areas
Acceleration	The pacing of the programme can be adjusted to decrease the speed of learning and increase the depth, or to increase the speed by requiring fewer tasks to master a standard, which allows the student to pursue advanced content.
Complexity	Additional variables, multiple resources or more difficult questions may be posed. Students are required to practise higher-order thinking skills.
Depth	Students are required to apply concepts in multiple ways and generate knowledge by themselves.
Challenge	The content discussed can be more sophisticated and require a larger amount of reasoning.
Creativity	Students can be asked to construct a model based on a concept studied, have opportunities to complete alternative tasks or products of their choosing, or represent new learning in their personal choice of mediums, with an emphasis on oral and written communication to real-world audiences.
Abstractness	Students are required to focus on conceptual thinking within and across disciplines. They may examine the generalizations behind a specific concept, formulate their own generalizations, or move from concrete applications to more abstract ways of thinking about a concept or discipline.

Therefore, the content of the programme should require less drilling or memorization tasks, but focus on demonstrating how a small concept or a simple theorem can be generalized into a different theory of mathematics. Problems involved should be challenging enough and allow in-depth exploration. Moreover, the programme should demonstrate problems that can be solved using different approaches.

Robinson and Campbell (2010) suggested some practices particularly appropriate for gifted students.

- Teachers can set a fast learning pace, devoting little time to reinforcement in lessons.
- Teachers can assume high levels of motivation and good behavior in students.
- Teachers can engage in co-constructing knowledge with their students rather than, in addition to, transmitting it.
- Teachers can encourage student self-assessment and meta-cognition for independent learning.

The above list can be the guidelines for teachers to adopt suitable strategies and lesson design. Teachers can act as facilitators to engage students in discovering knowledge and co-constructing new knowledge. The lesson can be designed to arouse and sustain the learning interest among students. Important self-learning skills and resources can be provided so that students can extend their learning beyond classrooms.

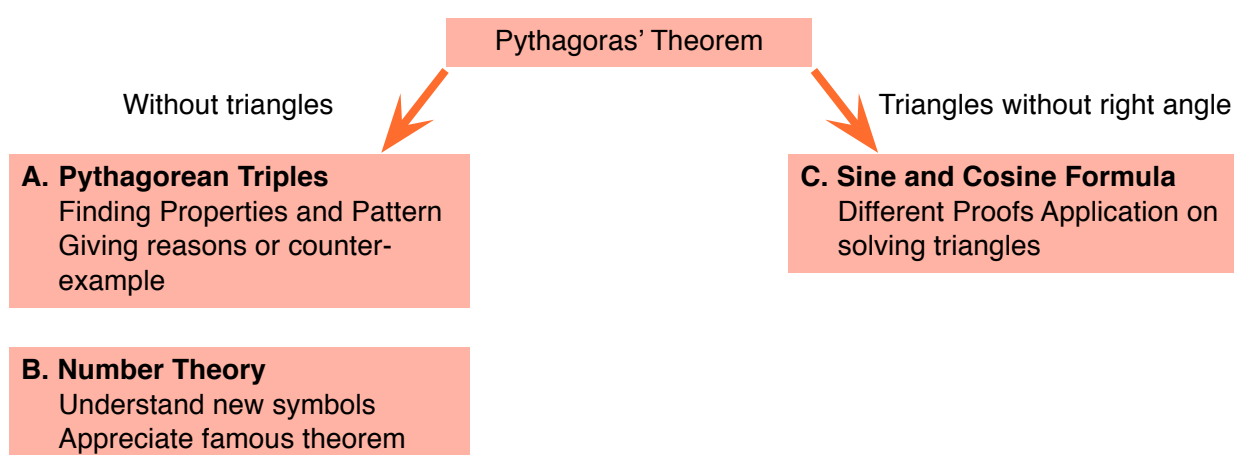
## Learning and Teaching Strategies

An interactive approach is preferred so as to enliven the learning atmosphere and to arouse active discussions amongst students, instead of relegating them to be merely passive learners. During the pull-out programme, students could mainly work in groups formed according to their mathematical ability and relationship. This allowed students to exchange ideas and stimulate one another's thoughts. Teachers could assign students to lead the whole-class discussion on some of the content.

Since the students selected were interested in mathematics and had good foundations, pre-lesson tasks were given to them to prepare for the learning. In the beginning of each lesson, students were chosen to present their pre-lesson work. The content of the lesson was mainly presented through a guided discovery approach. With the scaffolding provided in the worksheets, students were encouraged to discover new knowledge or to prove new results by themselves. For some problems, multiple solutions were provided to students to deepen their understanding. To extend students' learning outside the classroom, extension materials involving internet resources were provided at the end of each unit.

## Learning Content and Activities

This pull-out programme served as an extension of daily learning. The learning content was developed from Pythagoras' Theorem, which is usually taught in the S2 regular curriculum, in two different ways. One way was to explore the theorem about triangles without right angle. Another way was to investigate the integral solution of equations like ' $a^2 + b^2 = c^2$ ' without the context of triangles. The following figures summarize the learning content and the highlighted mathematical thinking skills of the programme, which can be divided into 3 learning units as shown in the table. Each unit requires 60 minutes to 90 minutes depending on the students' ability and the depth of the discussion.



Unit	Topic	Pre-lesson Tasks	Learning Content/ Activities	Extension Materials
A	Pythagorean Triples	<ul style="list-style-type: none"> <li>- Use of Python to generate 1000 Pythagorean triples</li> <li>- Pattern of Pythagorean Triples</li> </ul>	<ul style="list-style-type: none"> <li>- Formula about the triples</li> <li>- Inquiry tasks on patterns of triples</li> </ul>	<ul style="list-style-type: none"> <li>- 60-base system</li> <li>- Complex number</li> </ul>
B	Number Theory	<ul style="list-style-type: none"> <li>- Conditions for divisibility</li> </ul>	<ul style="list-style-type: none"> <li>- Introduction of Number Theory</li> <li>- Inquiry tasks on theorems in number theory</li> <li>- Story of Fermat's Last Theorem</li> </ul>	<ul style="list-style-type: none"> <li>- Basic theorem of congruence modulo</li> <li>- Proof about Irrational number</li> </ul>
C	Cosine Formula	<ul style="list-style-type: none"> <li>- Sine formula and area formula of triangle</li> </ul>	<ul style="list-style-type: none"> <li>- Limitation of Pythagoras' Theorem</li> <li>- Derivation of Cosine Formula</li> <li>- Solve a scalene triangle</li> </ul>	<ul style="list-style-type: none"> <li>- Other proofs of Cosine Formula</li> </ul>

The learning content were designed based on the theoretical framework about a curriculum for the gifted.

Features	Related Content
Acceleration	Unit C includes a topic in the S5 mathematics curriculum due to its relation with Pythagoras' Theorem. Unlike a regular curriculum, students learn this advanced topic focusing on different proofs of the formula rather than doing drilling practice.
Complexity	The learning tasks require students to apply different mathematical concepts and thinking skills. For example, to study the proof of cosine formula in Unit C, students need to apply knowledge about Pythagoras' Theorem, coordinate geometry and trigonometry. Moreover, most tasks in Unit B expect students to generate knowledge by themselves.
Depth	
Challenge	In most parts of the programme, students learn the content through problem-solving or guided discovery. All these problems in the programme require strong reasoning skills. In Unit B, students might find it challenging as they face new symbols and theorems in mathematics. In order to solve the problems, they also need to relate their knowledge about integers to the new theorems, look for patterns and express patterns with the new symbols.
Abstractness	In Unit A, students can see the importance of observing patterns, making judgments by proof or giving counter-examples in mathematics inquiry. Throughout the programme, students can also see how Pythagoras' Theorem can be generalized to important results in other disciplines of mathematics.

## Discussion

The programme was conducted as part of the S2 mathematics enrichment programme in the school. During the lesson, students were observed to have commitment in solving the challenging tasks and constructing mathematics knowledge. They did not give up easily and were willing to try. Some of them showed strong interest in the topics discussed in the lesson and the extension materials. However, students were not so active in group interaction and presentation. Teachers thought that this was because students were selected from different classes and hence needed some time to get used to the new classroom setting.

In the school, pre-lesson tasks and extension materials were provided as self-learning materials. Teachers may also have in-depth discussions about them within the lesson. If needed, teachers may separate each unit into more than one lesson. The focus of the programme is not just to solve the problem stated in the worksheets, but also to encourage students to make observations, judgements and generalizations. Teachers are encouraged to stimulate students' thought by asking more open ended questions like 'What else can you observe?', 'How can we prove it?', 'What else can you think of?'... The learning materials presented can only demonstrate some basic and introductory knowledge about the topics. Teachers are highly encouraged to enrich the units with related resources when adopting this exemplar.



# Lesson Plan

## Unit A

<b>Prior Knowledge</b>	<ul style="list-style-type: none"><li>- Pythagoras' Theorem</li><li>- Algebraic Identities about Squares</li></ul>
<b>Learning Objectives</b>	<ul style="list-style-type: none"><li>- Students can relate the triples with the square identities</li><li>- Students observe and describe some properties of the triples</li><li>- Students can justify whether a Mathematical statement is true or not with algebraic manipulations</li><li>- Students can justify whether a Mathematical statement is true or not with counter-examples</li><li>- Students develop better number sense</li></ul>
<b>Intended Learning Outcomes</b>	<ul style="list-style-type: none"><li>- Students demonstrate rigorous Mathematical reasoning, writing down step-by-step algebraic proof instead of just an example, a counter-example to disprove a statement, and their thoughts with suitable Mathematical symbols and words</li><li>- Students discover the properties of Pythagorean triples and get the correct answers for most of the questions on the worksheets</li><li>- Students will discuss or ask questions when they are in doubt</li><li>- Students present their findings to the whole class with confidence and clear voice</li></ul>
<b>Learning &amp; Teaching Strategies</b>	Guided Discovery Activities, Presentation

### Pre-lesson Tasks

1. Students use computer programming to generate a list of Pythagorean triples.
2. Students complete the proof of a property about Pythagorean triples.



## Procedure

Learning Focus	Activity / Content	Learning & Teaching Strategies
<b>Introduction</b>	<ol style="list-style-type: none"> <li>1. Review of Pythagorean Theorem and introduction of Pythagorean triples.</li> <li>2. Students present their solution of Task 2 of Pre-lesson Worksheet 1.</li> </ol>	Pre-lesson Worksheet 1
<b>Generating formula of Pythagorean triples</b>	<ol style="list-style-type: none"> <li>1. Discussion about the generating formula of Pythagorean triples:  <math>A=m^2-n^2</math>, <math>B=2mn</math>, <math>C=m^2+n^2</math>.</li> <li>2. Students try a few questions in an online quiz<sup>1</sup>.</li> <li>3. Students prove that the above substitution satisfies <math>A^2+B^2=C^2</math>.</li> <li>4. Teacher can provide further knowledge about the generating formula depending on the level of the students.</li> </ol>	Tablet for the online quiz
<b>Property of Pythagorean triples</b>	<ol style="list-style-type: none"> <li>1. Teacher explains the definition of "Primitive Pythagorean Triples".</li> <li>2. Students work in groups to explore the properties of the triples and answer questions in Lesson Worksheet 1.</li> <li>3. Students share their findings.</li> </ol>	Lesson Worksheet 1
<b>Summary and extension</b>	<ol style="list-style-type: none"> <li>1. Teacher summarizes some important skills, including the use of algebraic method to prove a statement and giving a counter-example to disprove a statement.</li> <li>2. Teacher introduces the extra materials and explain how the materials are related to the lesson. Students are encouraged to visit the websites.</li> </ol>	Lesson Worksheet 1

<sup>1</sup> <https://www.mathsisfun.com/numbers/pythagorean-triples.html>

### Extended Learning Activities

The following links are provided to students for further learning.

1. Website : Why We Still Use Babylonian Mathematics and the Base 60 System<sup>2</sup>
2. Video : Introduction to complex numbers<sup>3</sup>
3. Video : Finding Pythagorean triples from square of Complex numbers<sup>4</sup>

<sup>2</sup> <https://www.thoughtco.com/why-we-still-use-babylonian-Mathematics-116679>

<sup>3</sup> <https://www.youtube.com/watch?v=SP-YJe7Vldo>

<sup>4</sup> <https://www.youtube.com/watch?v=QJYmyhnaaek>

# Lesson Plan

## Unit B

<b>Prior Knowledge</b>	Basic concepts about factors, multiples and prime
<b>Learning Objectives</b>	<ul style="list-style-type: none"><li>- Students can develop better number sense</li><li>- Students understand some basic knowledge in number theory such as Divisibility, Prime Factorization, Congruence etc.</li><li>- Students carry out inquiry-based activity in number theory</li><li>- Students appreciate the hard work and persistence of Mathematicians</li></ul>
<b>Intended Learning Outcomes</b>	<ul style="list-style-type: none"><li>- Students can comprehend unfamiliar Mathematical symbols and theorems, by reading and finish the simple questions and task about congruence</li><li>- Students are committed to solving the problems, by trying even if they cannot get the answers immediately, and asking teaching for hints</li><li>- Students will discuss or ask questions when they are in doubt</li><li>- Students show interest about the story and history of Mathematical theorems and pay attention on presentation</li></ul>
<b>Learning &amp; Teaching Strategies</b>	Guided Discovery Activities, Presentation

### Pre-lesson Task

Students finish Pre-lesson Worksheet 2 about Divisibility Rule.

## Procedure

Learning Focus	Activity / Content	Learning & Teaching Strategies
<b>Divisibility Rule</b>	<ol style="list-style-type: none"> <li>1. Teacher introduces some basic knowledge such as Divisibility and Decimal number system.</li> <li>2. Students present their solution of Challenges 1,2 and 3 of Pre-lesson Worksheet 2.</li> </ol>	Pre-lesson Worksheet 2
<b>Formula for number of factors</b>	<ol style="list-style-type: none"> <li>1. Students work in groups to finish the Inquiry Activity 1 on Lesson Worksheet 2.</li> <li>2. Students share their findings.</li> </ol>	Lesson Worksheet 2
<b>Congruence and Fermat's Little Theorem</b>	<ol style="list-style-type: none"> <li>1. Students work in groups to complete the Inquiry Activity 2 on Lesson Worksheet 2.</li> <li>2. Teacher go through some parts to make sure students have the basic understanding about congruence after reading the first few sections of the worksheet.</li> <li>3. Students share their findings.</li> </ol>	Lesson Worksheet 2
<b>Story about Fermat's Last Theorem</b>	Teacher share the story about Fermat's Little Theorem.	
<b>Summary and extension</b>	Teacher summarizes some important skills of observing number patterns and relations, generalizing observation into a theorem, and understanding the definition of new Mathematical symbols.	

### Extended Learning Activities

The following links are provided for further learning. Teacher introduces the extra materials and explains how the materials are related to the lesson.

1. Prove that square root 2 is irrational: Making sense of irrational numbers<sup>5</sup> / The 5 Best Proofs that the Square Root of 2 is Irrational<sup>6</sup>
2. Fermat's little theorem visualization<sup>7</sup>
3. Fermat's little theorem examples<sup>8</sup>

<sup>5</sup> [https://www.youtube.com/watch?v=sbGjr\\_awePE](https://www.youtube.com/watch?v=sbGjr_awePE)

<sup>6</sup> <https://www.youtube.com/watch?v=lzkCVzzHHbg>

<sup>7</sup> <https://www.youtube.com/watch?v=OoQ16YCYksw>

<sup>8</sup> <https://www.youtube.com/watch?v=pMA-dD-KCWM>

# Lesson Plan

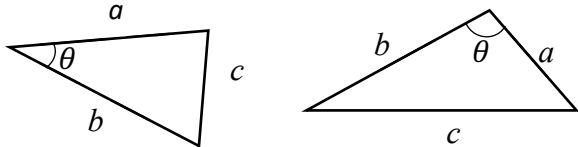
## Unit C

<b>Prior Knowledge</b>	<ul style="list-style-type: none"><li>- Pythagoras' Theorem</li><li>- Square Identities</li><li>- Trigonometric Ratios</li></ul>
<b>Learning Objectives</b>	<ul style="list-style-type: none"><li>- Students can solve triangle with enough given information</li><li>- Students understand a few proofs of Cosine Formula</li><li>- Students can relate Cosine Formula with Pythagoras Theorem</li><li>- Students appreciate the generalization from Pythagoras Theorem to Cosine Formula</li></ul>
<b>Intended Learning Outcomes</b>	<ul style="list-style-type: none"><li>- Students can comprehend unfamiliar Mathematical symbols and theorems, and understand new definition of trigonometric functions quickly</li><li>- Students are committed to solving the problems, by trying even if they cannot get the answers immediately, and asking teaching for hints</li><li>- Students demonstrates strong algebraic skills, by correctly expanding and simplifying expressions, and apply trigonometric identities like <math>(\sin^2\theta + \cos^2\theta = 1)</math> when simplifying expressions</li></ul>
<b>Learning &amp; Teaching Strategies</b>	Guided Discovery Activities, Presentation

### Pre-lesson Task

Students finish the Pre-lesson Worksheet 3 about Sine Formula and Area of Triangle.

## Procedure

Learning Focus	Activity / Content	Learning & Teaching Strategies
<b>Introduction</b>	<ol style="list-style-type: none"> <li>Teacher asks questions to check students' understanding about the pre-lesson knowledge of Sine Formula and Area Formula.</li> <li>Teacher introduces the topic using the last question in the Pre-lesson Worksheet 3: If the three sides of a triangle are given, but none of the angles are given, can you still find out the angles?</li> <li>Students are expected to point out the limitation of Sine Formula and the need for a new formula.</li> </ol>	Pre-lesson Worksheet 3
<b>Basic observation</b>	<ol style="list-style-type: none"> <li>Students are asked to draw an acute-angled triangle and an obtuse-angled triangle, denote <math>a, b, c, \theta</math> as shown, and measure the lengths of <math>a, b</math> and <math>c</math>.</li> </ol> <div style="text-align: center;">  </div> <ol style="list-style-type: none"> <li>Students are asked to discuss whether <math>a^2 + b^2</math> and <math>c^2</math> still have specific relation in the two triangles</li> <li>Teacher guides the students to summarize the following relation: For acute angle <math>\theta</math>, <math>a^2 + b^2 &gt; c^2</math> For right angle <math>\theta</math>, <math>a^2 + b^2 = c^2</math> (Pyth. Theorem) For obtuse angle <math>\theta</math>, <math>a^2 + b^2 &lt; c^2</math></li> </ol>	
<b>Basic knowledge</b>	<ol style="list-style-type: none"> <li>Students may see the trigonometric function (of angles greater than <math>90^\circ</math>), which is not learnt in S2 and S3 syllabuses.</li> <li>Teacher can briefly explain the definition of trigonometric function and identities like <math>\cos(180^\circ - \theta) = -\cos \theta</math>.</li> </ol>	
<b>Proofs / deduction of Cosine Formula</b>	<ol style="list-style-type: none"> <li>Students work in groups to complete Lesson Worksheet 3 about a few proofs of Cosine Formula. <ul style="list-style-type: none"> <li>Using the distance formula</li> <li>Using trigonometry</li> <li>Using the Pythagorean theorem</li> </ul> </li> <li>Students share their findings.</li> </ol>	Lesson Worksheet 3
<b>Practice questions</b>	Students work individually to practice the use of sine formula, cosine formula and area formula.	Lesson Worksheet 4

Learning Focus	Activity / Content	Learning & Teaching Strategies
<b>Origami activity</b>	Teacher leads the students to prove the cosine formula by origami method.	Origami materials
<b>Summary and extension</b>	Teacher summarizes that the Cosine Formula is a generalization of Pythagoras Theorem. Pythagoras Theorem is a particular case of Cosine Formula when the angle is a right angle. This kind of generalization is common in Mathematics study.	

### Extended Learning Activity

An extension worksheet is provided to show how to prove cosine formula using sine formula.

# Unit A

## Pre-lesson Worksheet 1

### Pythagorean Triple

A triple means three numbers.

If a triple  $(a, b, c)$  satisfies the equation  $a^2 + b^2 = c^2$ , we call it a Pythagorean Triple.

- e.g.  $(3, 4, 5)$  is a Pythagorean Triple.  $(3^2 + 4^2 = \underline{\quad}$  and  $5^2 = \underline{\quad})$   
 $(5, 12, 13)$  is / is not a Pythagorean Triple.  $(5^2 + 12^2 = \underline{\quad}$  and  $13^2 = \underline{\quad})$   
 $(4, 5, 8)$  is / is not a Pythagorean Triple.  $(4^2 + 5^2 = \underline{\quad}$  and  $8^2 = \underline{\quad})$

**Task 1** Generate 1000 Pythagorean triples using Python (A computer program).

Steps:

1. Download Python using the link: <https://www.python.org/ftp/python/3.6.4/python-3.6.4.exe>

**Make sure to untick “download for all users” in order to make the installation proceed.**

2. Set up Python in your computer by the following

*Computer > System properties > Advanced system settings > Environment variables*

Under system variables, click *New...* to create a new variable. Put Python as the *Variable name*, and

For the *Variable value*, input the address in which you have installed Python, e.g.

C:\Users\OWNER\AppData\Local\Programs\Python\Python36-32

Make sure this is the folder which contains the application python.exe

3. In the start menu, search “idle”. Open the application *IDLE (Python 3.6 32-bit)*. Click *File > New File*.

Copy the following lines to the new document:

```
import math
n = 10000
i = 0
for a in range(1,n):
    for b in range(a+1,n):
        k = math.sqrt(a*a+b*b)
        if int(k) == k and i < 1001 :
            print(a,b,int(k))
            i = i + 1
```

# Unit A

## Pre-lesson Worksheet 1

4. Press **Ctrl + S** to save the document. Press **F5** to run the file. You should be able to see that 1000 Pythagorean triples are generated in IDLE. Congratulations! Copy the whole list to a word document and save it. Print it out and submit it to your teacher in the next enrichment class.

### Task 2 Proving a property of Pythagorean triple

Look at the Pythagorean triples  $(a, b, c)$ , with the arrangement  $a < b < c$  and  $a$  is a prime number.

$(3, 4, 5)$     $(5, 12, 13)$     $(7, 24, 25)$     $(11, 60, 61)$     $(13, 84, 85)$

If the smallest number is a prime number, then the other two numbers differ by 1.

**Proposition** Let  $(a, b, c)$  be a Pythagorean triple, where  $a < b < c$  and  $a^2 + b^2 = c^2$ .  
If  $a$  is a prime number, then  $c = b + 1$ .

*Proof* Since  $(a, b, c)$  be a Pythagorean triple,

$$\text{we have } \underline{\hspace{2cm}}^2 + \underline{\hspace{2cm}}^2 = \underline{\hspace{2cm}}^2.$$

Hence,

$$\begin{aligned} a^2 &= \underline{\hspace{2cm}}^2 - \underline{\hspace{2cm}}^2 \\ &= (\underline{\hspace{2cm}} + \underline{\hspace{2cm}})(\underline{\hspace{2cm}} - \underline{\hspace{2cm}}) \end{aligned}$$

So both  $\underline{\hspace{2cm}} + \underline{\hspace{2cm}}$  and  $\underline{\hspace{2cm}} - \underline{\hspace{2cm}}$  are factors of  $a^2$ .

But  $a$  is a prime, so the only factors of  $a^2$  are  $1$ ,  $\underline{\hspace{2cm}}$  and  $\underline{\hspace{2cm}}$ .

Hence there are only two cases:

Case 1:  $\underline{\hspace{2cm}} + \underline{\hspace{2cm}} = a$  and  $\underline{\hspace{2cm}} - \underline{\hspace{2cm}} = a$

Then :  $\underline{\hspace{2cm}} + \underline{\hspace{2cm}} = \underline{\hspace{2cm}} - \underline{\hspace{2cm}}$   
 $b = \underline{\hspace{2cm}}$  and  $c = \underline{\hspace{2cm}}$ , which is not possible.

Case 2:  $\underline{\hspace{2cm}} + \underline{\hspace{2cm}} = a^2$  and  $\underline{\hspace{2cm}} - \underline{\hspace{2cm}} = 1$

So we must be in case 2, and the second equation gives  $c = b + 1$ . (end of proof)

**Question:** Is the converse of the **Proposition** true?

Let  $(a, b, c)$  be a Pythagorean triple, where  $a < b < c$  and  $a^2 + b^2 = c^2$ .

If  $c = b + 1$ , is it true that  $a$  is always a prime number?

[ Hint: Look at the list of Pythagorean Triple again! ]



# Unit A

## Lesson Worksheet 1

### Properties of Pythagorean Triples

For a Pythagorean triple  $(a, b, c)$ , if  $a, b$  and  $c$  are coprime, i.e. no common factor except 1, We call it a Primitive Pythagorean triple.

Primitive Pythagorean triple  $(a, b, c)$

m	n	(a) $m^2-n^2$	(b) $2mn$	(c) $m^2+n^2$
2	1	3	4	5
3	2	5	12	13
4	1	15	8	17
4	3	7	24	25
5	2	21	20	29
5	4	9	40	41
6	1	35	12	37
6	5	11	60	61
7	2	45	28	53
7	4	33	56	65
7	6	13	84	85
8	1	63	16	65
8	3	55	48	73
8	5	39	80	89
8	7	15	112	113
9	2	77	36	85
9	4	65	72	97

9	8	17	144	145
10	1	99	20	101
10	3	91	60	109
10	7	51	140	149
10	9	19	180	181
11	2	117	44	125
11	4	105	88	137
11	6	85	132	157
11	8	57	176	185
11	10	21	220	221
12	1	143	24	145
12	5	119	120	169
12	7	95	168	193
12	11	23	264	265
13	2	165	52	173
13	4	153	104	185
13	6	133	156	205
13	8	105	208	233
13	10	69	260	269

# Unit A

## Lesson Worksheet 1

**Task 1** Pattern of  $\frac{(c-a)(c-b)}{2}$

For a primitive Pythagorean triple  $(a, b, c)$ , what kind of number  $\frac{(c-a)(c-b)}{2}$  should be?

Q1) Choose some sets of primitive Pythagorean triples, evaluate  $\frac{(c-a)(c-b)}{2}$ .

For  $a = \underline{3}$ ,  $b = \underline{4}$ ,  $c = \underline{5}$ ,  $\frac{(c-a)(c-b)}{2} =$

For  $a = \underline{\quad}$ ,  $b = \underline{\quad}$ ,  $c = \underline{\quad}$ ,  $\frac{(c-a)(c-b)}{2} =$

For  $a = \underline{\quad}$ ,  $b = \underline{\quad}$ ,  $c = \underline{\quad}$ ,  $\frac{(c-a)(c-b)}{2} =$

For  $a = \underline{\quad}$ ,  $b = \underline{\quad}$ ,  $c = \underline{\quad}$ ,  $\frac{(c-a)(c-b)}{2} =$

Q2a) What kind of numbers  $\frac{(c-a)(c-b)}{2}$  are?

For a primitive Pythagorean triple  $(a, b, c)$ ,  $\frac{(c-a)(c-b)}{2}$  is a \_\_\_\_\_ number.

Q2b) Can you prove your suggestion? [Hint: use the formula  $a = m^2 - n^2$ ,  $b = 2mn$ ,  $c = m^2 + n^2$ ]

$$\frac{(c-a)(c-b)}{2} =$$

Q3) Is the converse true? If not, give a counter-example.

**Converse:**

If  $\frac{(c-a)(c-b)}{2}$  \_\_\_\_\_, then \_\_\_\_\_.

**True / Not true.**

**Explanation:**

# Unit A

## Lesson Worksheet 1

### Task 2 $a, b$ and $c$ , odd or even?

For a primitive Pythagorean triple  $(a, b, c)$ ,

Q1) Can all  $a$ ,  $b$  and  $c$  be odd? Explain your answer.

Q2) As the primitive Pythagorean triple are coprime, can all  $a$ ,  $b$  and  $c$  be even?

Q3) Try to summarize how  $a, b$  and  $c$  be odd or even.

---

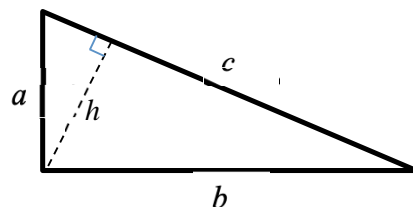
### Task 3 **Height of Triangle with length $(a, b, c)$ .**

Given a primitive Pythagorean triple  $(a, b, c)$ , if we construct a triangle with length  $a, b$  and  $c$ .

Q1) What kind of triangle is it?

Q2) Let  $h$  be the altitude (the height) of the triangle with respect to  $c$ .

Express  $h$  in terms of  $a, b$  and  $c$ .



Q3) Can  $h$  be an integer? Explain your answer.

# Unit A

## Lesson Worksheet 1

### Task 4 Factors of $a$ , $b$ and $c$

For a primitive Pythagorean triple  $(a, b, c)$ ,

Q1) Can you observe any factors of  $a$ ,  $b$  and  $c$ ?

Q2) What is the largest number that always divides  $abc$ ?

Q3) Observe  $c$ . What is the general pattern of  $c$ ?

---

### Extra Materials:

1. Following Task 4, there is a reason why the base 60 system is used in the history.

You can watch the video.

Why We Still Use Babylonian  
Mathematics and the Base 60 System



2. Pythagorean triple can be studied in the view of complex number.

You can watch the following two videos to understand more.

Introduction to  
complex numbers



Finding Pythagorean triples  
from square of Complex numbers



# Unit A

## Suggested Answers and Guidelines

### Suggested Answers and Guidelines for Unit A

#### Pre-lesson Worksheet 1

##### Task 2

*Proof* Since  $(a, b, c)$  be a Pythagorean triple,  
we have  $a^2 + b^2 = c^2$ .

Hence,

$$\begin{aligned} a^2 &= c^2 - b^2 \\ &= (c + b)(c - b) \end{aligned}$$

So both  $c + b$  and  $c - b$  are factors of  $a^2$ .

But  $a$  is a prime, so the only factors of  $a^2$  are  $1, a$  and  $a^2$ .

Hence there are only two cases:

Case 1:  $c + b = a$  and  $c - b = a$

Then :  $c + b = c - b$

$b = 0$  and  $c = 0$ , which is not possible.

Case 2:  $c + b = a^2$  and  $c - b = 1$

So we must be in case 2, and the second equation gives  $c = b + 1$ . (end of proof)

**Question:** Is the converse of the **Proposition** true?

Let  $(a, b, c)$  be a Pythagorean triple, where  $a < b < c$  and  $a^2 + b^2 = c^2$ .

If  $c = b + 1$ , is it true that  $a$  is always a prime number?

[ Counter-example:  $(9, 40, 41)$  ]

# Unit A

## Suggested Answers and Guidelines

### Lesson Worksheet 1

Observe the following triples and answer the questions:

Primitive Pythagorean triple  $(a, b, c)$

m	n	(a) $m^2-n^2$	(b) $2mn$	(c) $m^2+n^2$
2	1	3	4	5
3	2	5	12	13
4	1	15	8	17
4	3	7	24	25
5	2	21	20	29
5	4	9	40	41
6	1	35	12	37
6	5	11	60	61
7	2	45	28	53
7	4	33	56	65
7	6	13	84	85
8	1	63	16	65
8	3	55	48	73
8	5	39	80	89
8	7	15	112	113
9	2	77	36	85
9	4	65	72	97

9	8	17	144	145
10	1	99	20	101
10	3	91	60	109
10	7	51	140	149
10	9	19	180	181
11	2	117	44	125
11	4	105	88	137
11	6	85	132	157
11	8	57	176	185
11	10	21	220	221
12	1	143	24	145
12	5	119	120	169
12	7	95	168	193
12	11	23	264	265
13	2	165	52	173
13	4	153	104	185
13	6	133	156	205
13	8	105	208	233
13	10	69	260	269

\*\*\*\*\*

# Unit A

## Suggested Answers and Guidelines

**Task 1** Pattern of  $\frac{(c-a)(c-b)}{2}$

For a primitive Pythagorean triple  $(a, b, c)$ , what kind of number  $\frac{(c-a)(c-b)}{2}$  should be?

Q1) Choose some sets of primitive Pythagorean triples, evaluate  $\frac{(c-a)(c-b)}{2}$ .

1, 4, 9, 16, ...

Q2a) What kind of numbers the  $\frac{(c-a)(c-b)}{2}$  are?

Findings:  $\frac{(c-a)(c-b)}{2}$  must be a square number.

Q2b) Can you prove your suggestion? [Hint: use the formula  $a = m^2 - n^2$ ,  $b = 2mn$ ,  $c = m^2 + n^2$ ]

Proof:

$$\begin{aligned}\frac{(c-a)(c-b)}{2} &= \frac{(m^2 + n^2 - m^2 + n^2)(m^2 + n^2 - 2mn)}{2} \\ &= \frac{2n^2(m^2 - 2mn + n^2)}{2} \\ &= n^2(m^2 - 2mn + n^2) \\ &= n^2(m-n)^2 \\ &= [n(m-n)]^2\end{aligned}$$

Q3) Is the converse true? If not, give an example.

**Converse:**

If  $\frac{(c-a)(c-b)}{2}$  is a square number, then  $(a, b, c)$  is a primitive Pythagorean triple.

Not true

e.g.  $\frac{(3-1)(3-2)}{2} = 1$  is a square number while  $(1, 2, 3)$  is not a Pythagorean triple.

To construct such example, teacher can guide students to start with a square number,

e.g. : 4

$$\frac{(c-a)(c-b)}{2} = 4 \Rightarrow (c-a)(c-b) = 8$$

Look for factors of 8,  $8 = 1 \times 8$  and  $2 \times 4$ , then make a  $(c-a)(c-b)$  pattern.

e.g.  $2 \times 4 = (7-5)(7-3)$ , while  $(3, 5, 7)$  are not a Pythagorean triple.

# Unit A

## Suggested Answers and Guidelines

### Task 2 $a, b$ and $c$ , odd or even?

Properties of Pythagorean Triples

Q1) Can all  $a, b$  and  $c$  be odd?

No. As “odd” + “odd” = “even”

Q2) As the primitive Pythagorean triple are coprime, can all  $a, b$  and  $c$  be even?

No. They should be coprime

Q3) Try to summarize how  $a, b$  and  $c$  be odd or even.

Exactly one of  $a, b$  is odd;  $c$  is odd.

\*\*\*\*\*

### Task 3 **Height of Triangle with length $(a, b, c)$ .**

Given a primitive Pythagorean triple  $(a, b, c)$ , if we construct a triangle with length  $a, b$  and  $c$ .

Q1) What kind of triangle is it?

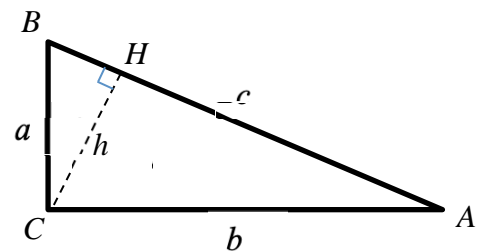
Right-angled triangle.

Q2) Let  $h$  be the altitude (the height) of the triangle with respect to  $c$ .

Express  $h$  in terms of  $a, b$  and  $c$ .

Method 1 . Area relation

$$\begin{aligned}\frac{ab}{2} &= \frac{ch}{2} \\ ab &= ch \\ h &= \frac{ab}{c}\end{aligned}$$



Method 2 . Similar Triangle

$$\Delta ACH \sim \Delta ABC$$

$$\begin{aligned}\frac{CH}{BC} &= \frac{AC}{AB} \\ \frac{h}{a} &= \frac{b}{c} \\ h &= \frac{ab}{c}\end{aligned}$$



# Unit A

## Suggested Answers and Guidelines

### Task 4 Factors of $a$ , $b$ and $c$

Q1) Can you observe any factors of  $a$ ,  $b$  and  $c$ ?

- Exactly one of  $a, b$  is divisible by 3.
- Exactly one of  $a, b$  is divisible by 4.
- Exactly one of  $a, b, c$  is divisible by 5.

Q2) What is the largest number that always divides  $abc$ ?

60

Q3) Observe  $c$ . What is the general pattern of  $c$ ?

- $c$  is in the form  $4n + 1$ .

### Extra Materials:

1. Following Task 4, there is a reason why the base 60 system is used in the history.

You can watch the video.

Why We Still Use Babylonian  
Mathematics and the Base 60 System



2. Pythagorean triple can be studied in the view of complex number.

You can watch the following two videos to understand more.

Introduction to  
complex numbers



Finding Pythagorean triples  
from square of Complex numbers



# Unit B

## Pre-lesson Worksheet 2

### Number Theory

#### Divisibility Rules

How do we know whether the number 2718594235 is divisible by 3 [可被 3 整除] ?

Or is it divisible by 11? In the worksheet, we will look for a few rules.

**Rule 1**  $n$  is divisible by 3 if the sum of digits of  $n$  is divisible by 3 .

Example  $n = 756$ .

The sum of digits is  $7 + 5 + 6 = 18$  , which is divisible by 3.

Hence, 756 is divisible by 3. [  $756 \div 3 = 252$  ]

Example  $n = 2156$ .

The sum of digits is  $2 + 1 + 5 + 6 = 14$  , which is NOT divisible by 3.

Hence, 2156 is NOT divisible by 3. [  $2156 \div 3 = 718.66666\dots$  ]

Ex1: Check whether the following number is divisible by 3 using **Rule 1**.

124473 ( Yes / No )          2718234 ( Yes / No )

**Rule 2**  $n$  is divisible by 9 if the sum of digits of  $n$  is divisible by 9 .

Example  $n = 812673$ .

The sum of digits  $8 + 1 + 2 + \quad + \quad + \quad = \quad$  , which ( is / is not ) divisible by 9.

Hence 812673 ( is / is not ) divisible by 9 .

Example  $n = 23156$ .

The sum of digits is  $2 + \quad + \quad + \quad = \quad$  , which ( is / is not ) divisible by 9.

Hence 23156 ( is / is not ) divisible by 9.

Ex2: Check whether the following number is divisible by 9 using **Rule 2**.

1781253 ( Yes / No )          5412687 ( Yes / No )

# Unit B

## Pre-lesson Worksheet 2

**Rule 3**  $n$  is divisible by 11 if the *alternating* sum of digits of  $n$  is divis

Example  $n = 2739$ .

The alternating sum of digits of  $n$  is  $2 - 7 + 3 - 9 = \underline{\hspace{2cm}}$ ,

which ( is / is not ) divisible by 11 . Hence 2739 ( is / is not ) divisible by 11 .

Example  $n = 1426859$ .

The alternating sum of digits of  $n$  is  $1 - 4 + 2 - 6 + 8 - 5 + 9 = \underline{\hspace{2cm}}$ ,

which ( is / is not ) divisible by 11 . Hence 1426859 ( is / is not ) divisible by 11 .

Ex3: Check whether the following number is divisible by 11 using **Rule 3**.

326095 ( Yes / No )                      99887766554433221100 ( Yes / No )

After learning the rules, can you figure out the reasons behind? Try the following challenges.

### Challenge 1

Why does **Rule 1** work?

We can write  $756 = 7 \times \underline{\hspace{1cm}} + 5 \times \underline{\hspace{1cm}} + 6$

Then,

$$756 = 7 \times (\underline{\hspace{1cm}} + 1) + 5 \times (\underline{\hspace{1cm}} + 1) + 6$$

$$= 7 \times \underline{\hspace{1cm}} + \underline{\hspace{1cm}} + 5 \times \underline{\hspace{1cm}} + 5 + 6$$

$$= 3 \times (\underline{\hspace{3cm}}) + 7 + 5 + 6$$

So if  $7 + 5 + 6$  is divisible by 3 , the whole expression will be divisible by 3 .

### Challenge 2

Can you show why Rule 2 and Rule 3 work ?

### Challenge 3

How can we check whether a number is divisible by 4 ?

Design a rule and explain your design.

Ex: Check whether the following number is divisible by 4 using your rule.

1256096 ( Yes / No )                      129571268 ( Yes / No )

# Unit B

## Lesson Worksheet 2

### Inquiry Activity 1 --- Prime Factorization and Number of Factors

Example: Consider the number 36

Prime Factorization :  $36 = 2^2 \times 3^2$

$36 = 1 \times 36$  ,  $2 \times 18$  ,  $3 \times 12$  ,  $4 \times 9$  ,  $6 \times 6$

Factors of 36 : 1, 2, 3, 4, 6, 9, 18, 36      Number of Factors: 9

Following the example and fill in the table.

Number	Prime Factorization	Factors	No. of Factors
36	$36 = 2^2 \times 3^2$	1,2,3,4,6,9,18,36	9
56			
72			
510			
700			
3125			

#### Question 1

Can you find out the relation between the Prime Factorization and the number of factors?

[ Hint: Look at the indices in the Prime Factorization. ]

#### Question 2

Apply your conclusion in Question 1 to find out the number of factors for the following numbers.

$250 = 2 \times 5^3$        $\rightarrow$  Number of factors = \_\_\_\_\_

$1156375 = 5^3 \times 11 \times 29^2$        $\rightarrow$  Number of factors = \_\_\_\_\_

$864 =$        $\rightarrow$  Number of factors = \_\_\_\_\_

#### Question 3

Can you explain/prove your conclusion about the number of factors?

# Unit B

## Lesson Worksheet 2

### Inquiry Activity 2 --- Fermat Little Theorem

Fermat's Little theorem is related to a pattern about remainder. In this worksheet, we are going to deduce the theorem.

#### Part I : Introducing a new symbol

If  $a$  and  $b$  have the same remainder when divided by a number  $k$ ,  
we write : '  $a \equiv b \pmod{k}$  '. We call it '  $a$  is congruent to  $b$  modulo  $k$  '.

E.g. When 62 is divided by 7, the remainder is 6. When 27 is divided by 7, the remainder is also 6.

So, we write  $62 \equiv 27 \pmod{7}$

#### Practice: True or False

$43 \equiv 27 \pmod{4}$  True / False

$74 \equiv 27 \pmod{11}$  True / False

$66 \equiv 49 \pmod{3}$  True / False

$63 \equiv 70 \pmod{7}$  True / False

#### Practice: Fill in the blank with a suitable number

Fill in a number less than 7 on the line:

$55 \equiv \underline{\hspace{1cm}} \pmod{7}$

Fill in a number less than 10 on the line:

$123 \equiv \underline{\hspace{1cm}} \pmod{10}$

Fill in a number between 30 and 40 on the line:

$65 \equiv \underline{\hspace{1cm}} \pmod{8}$

Fill in a number between 30 and 40 on the line:

$19 \equiv \underline{\hspace{1cm}} \pmod{9}$

#### Part II : Basic Theorem

To look into the Fermat's Theorem, we will first look at some basic theorem about the remainder.

**Theorem 1** If  $a \equiv b \pmod{k}$  and  $c \equiv d \pmod{k}$ , then  $ac \equiv bd \pmod{k}$

**Examples:**  $17 \equiv 3 \pmod{7}$  and  $9 \equiv 2 \pmod{7}$ , therefore  $17 \times 9 \equiv 3 \times 2 = 6 \pmod{7}$

[ Check:  $17 \times 9 = 153$  | For  $153 \div 7$ , remainder = 6 ]

$23 \equiv 5 \pmod{6}$  and  $19 \equiv 1 \pmod{6}$ , therefore  $23 \times 19 \equiv \underline{\hspace{1cm}} \times \underline{\hspace{1cm}} = \underline{\hspace{1cm}} \pmod{6}$

[ Check:  $23 \times 19 = 437$  | For  $437 \div 6$ , remainder =  $\underline{\hspace{1cm}}$  ]

Since  $11 \equiv 5 \pmod{5}$ ,  $19 \equiv \underline{\hspace{1cm}} \pmod{6}$ ,  $33 \equiv \underline{\hspace{1cm}} \pmod{6}$ ,

therefore  $11 \times 19 \times 33 \equiv \underline{\hspace{2cm}} = \underline{\hspace{1cm}} \pmod{6}$

**Proof of Theorem 1:** Hint: If  $a \equiv b \pmod{k}$ , we can write that  $a - b = k \times M$ , where  $M$  is an integer.  
If  $c \equiv d \pmod{k}$ , we can write that  $c - d = k \times N$ , where  $N$  is an integer.  
Try to show  $ac - bd = k(\dots)$ , where the expression in the bracket is an integer.

# Unit B

## Lesson Worksheet 2

**Theorem 2** Let  $h$  be a number coprime with  $k$ . (Coprime means that  $h$  and  $k$  have no common factor except 1)  
 If  $ha \equiv hb \pmod{k}$ , then  $a \equiv b \pmod{k}$ .

**Example:**  $44 \equiv 16 \pmod{7}$  44 and 16 has a common factor 4, which is coprime with 7.

When we divide 4 from both sides, the relation is still true.

$44 \equiv 16 \pmod{7}$     **divide 4**  $\rightarrow$      $11 \equiv 4 \pmod{7}$  is also true.

$65 \equiv 25 \pmod{8}$     **divide 5**  $\rightarrow$      $13 \equiv 5 \pmod{8}$  is also true.

$82 \equiv 10 \pmod{8}$     **divide 2**  $\rightarrow$      $41 \equiv 5 \pmod{8}$  which is a False relation.

Why can't we divide 2 from both sides here? \_\_\_\_\_

### Proof of Theorem 2:

**Question :** Is the following true? Explain your answer.

If  $a \equiv b \pmod{k}$  and  $c \equiv d \pmod{k}$ , then  $a + c \equiv b + d \pmod{k}$

### Part III : Observation

Fermat's Little Theorem is about a prime number  $p$  and another number  $a$  such that  $a$  and  $p$  are coprime.

E.g.1 Let $p = 5$ and $a = 7$	
Multiple of $a$	Remainder when divided by $p$ (Write a number less than 5)
$1a = 7$	$7 \equiv \underline{\quad} \pmod{5}$
$2a = 14$	$14 \equiv \underline{\quad} \pmod{5}$
$3a = 21$	$21 \equiv \underline{\quad} \pmod{5}$
$4a = 28$	$28 \equiv \underline{\quad} \pmod{5}$

E.g.2 Let $p = 5$ and $a = 13$	
Multiple of $a$	Remainder when divided by $p$ (Write a number less than 5)
$1a = 13$	$13 \equiv \underline{\quad} \pmod{5}$
$2a = 26$	$26 \equiv \underline{\quad} \pmod{5}$
$3a = 39$	$39 \equiv \underline{\quad} \pmod{5}$
$4a = 52$	$52 \equiv \underline{\quad} \pmod{5}$

### Observation:

When  $p = 5$ , the first 4 multiple of  $a$  gives the reminders:  $\underline{\quad}, \underline{\quad}, \underline{\quad}, \underline{\quad}$  when divided by  $p$ .

# Unit B

## Lesson Worksheet 2

E.g.3 Let $p = 7$ and $a = 3$	
Multiple of $a$	Remainder when divided by $p$ (Write a number less than 7)
$1a = 3$	$3 \equiv \underline{\quad} \pmod{7}$
$2a = 6$	$6 \equiv \underline{\quad} \pmod{7}$
$3a = 9$	$9 \equiv \underline{\quad} \pmod{7}$
$4a = 12$	$12 \equiv \underline{\quad} \pmod{7}$
$5a = 15$	$15 \equiv \underline{\quad} \pmod{7}$
$6a = 18$	$18 \equiv \underline{\quad} \pmod{7}$

E.g.4 Let $p = 7$ and $a = 11$	
Multiple of $a$	Remainder when divided by $p$ (Write a number less than 7)
$1a = 11$	$11 \equiv \underline{\quad} \pmod{7}$
$2a = 22$	$22 \equiv \underline{\quad} \pmod{7}$
$3a = 33$	$33 \equiv \underline{\quad} \pmod{7}$
$4a = 44$	$44 \equiv \underline{\quad} \pmod{7}$
$5a = 55$	$55 \equiv \underline{\quad} \pmod{7}$
$6a = 66$	$66 \equiv \underline{\quad} \pmod{7}$

**Observation:**

When  $p = 7$ , the first  $\underline{\quad}$  multiple of  $a$  gives the remainders:  $\underline{\hspace{2cm}}$  when divided by  $p$ .

**Part IV : Apply the theorem**

The first  $(p - 1)$  multiples of  $a$  :  $\underline{a}$  ,  $\underline{2a}$  ,  $\underline{3a}$  , ...,  $\underline{(p-1)a}$  gives the remainders  $\underline{\hspace{2cm}}$  , when they are divided by  $p$ .

By Theorem 1, we can multiply them together and give the relation:

$$(a)(2a)(3a) \dots [(p-1)a] \equiv \underline{\hspace{2cm}} \pmod{p}$$

$$1 \times 2 \times 3 \dots \times (p-1) \times a^{p-1} \equiv \underline{\hspace{2cm}} \pmod{p}$$

Do  $1 \times 2 \times 3 \dots \times (p-1)$  and  $p$  have common factor?  $\underline{\hspace{2cm}}$

By Theorem 2,  $a^{p-1} \equiv \underline{\quad} \pmod{p}$

**Conclusion: Fermat's Little Theorem**

If  $p$  is a prime number and  $a$  is coprime with  $p$ , then  $a^{p-1} \equiv \underline{\quad} \pmod{p}$

# Unit B

## Suggested Answers and Guidelines

### Suggested Answers and Guidelines for Unit B

#### Pre-lesson Worksheet 2

Ex1: Yes, Yes

Ex2: Yes, No

Ex3: No, Yes

Why does **Rule 1** work?

We can write  $756 = 7 \times \underline{100} + 5 \times \underline{10} + 6$

Then,

$$\begin{aligned}756 &= 7 \times (\underline{99} + 1) + 5 \times (\underline{9} + 1) + 6 \\ &= 7 \times \underline{99} + \underline{7} + 5 \times \underline{9} + \underline{5} + 6 \\ &= 3 \times (\underline{7 \times 33} + \underline{5 \times 3}) + 7 + 5 + 6\end{aligned}$$

So if  $7 + 5 + 6$  is divisible by 3, the whole expression will be divisible by 3.

Rule 2 is similar to Rule 1

Rule 3, observe that

$$10 = 11 - 1$$

$$100 = 99 + 1 = 11 \times 9 + 1$$

$$1000 = 1001 - 1 = 11 \times 91 - 1$$

$$10000 = 9999 + 1 = 11 \times 909 + 1$$

...

Rule for 4: Only need to check the last two digits

e.g.  $104928 = 1049 \times 100 + 28 = 1049 \times 25 \times 4 + 28$ . Therefore, we only need to check 28.



# Unit B

## Suggested Answers and Guidelines

### Lesson Worksheet 2

Example: Consider the number 36

Prime Factorization :  $36 = 2^2 \times 3^2$

$36 = 1 \times 36$  ,  $2 \times 18$  ,  $3 \times 12$  ,  $4 \times 9$  ,  $6 \times 6$

Factors of 36 : 1, 2, 3, 4, 6, 9, 18, 36      Number of Factors: 9

Following the example, fill in the table.

Number	Prime Factorization	Factors	No. of Factors
36	$36 = 2^2 \times 3^2$	1,2,3,4,6,9,18,36	9
56	$56 = 7^1 \times 2^3$	1,2,4,7,8,14,28,56	8
72	$72 = 2^3 \times 3^2$	1,2,3,4,6,8,9,12,18,24,36,72	12
510	$510 = 2 \times 3 \times 5 \times 17$	1,2,3,5,15,17,30,34,102,170,255,510	16
700	$700 = 2^2 \times 5^2 \times 7$	1,2,4,5,7,10,14,20,25,28,35,50,70,100,140,175,350,700	18
3125	$3125 = 5^5$	1,5,25,125,625,3125	6

### Question 1

Can you find out the relation between the Prime Factorization and the number of factors?

[ Hint: Look at the Indices of the Prime Factorization. ]

Number of Factors = Product of all (index + 1) in the prime factorization.

### Question 2

Apply your conclusion in question 1 to find out the number of factors for the following numbers.

$250 = 2 \times 5^3$        $\rightarrow$  Number of factors = 8

$1156375 = 5^3 \times 11 \times 29^2$        $\rightarrow$  Number of factors = 24

$864 = 2^5 \times 3^3$        $\rightarrow$  Number of factors = 24

### Question 3

Can you explain/prove your conclusion about the number of factors ?

Taking  $72 = 2^3 \times 3^2$  as example,

We observe that each factor is formed by choosing (0/1/2/3) for the index on 2, and (0/1/2) for the index on 3

e.g.  $9 = 3^2$  ,  $12 = 2^2 \times 3$

Therefore, (0/1/2/3)  $\rightarrow$  4 choices, (0/1/2)  $\rightarrow$  3 choices . Number of Factors =  $4 \times 3 = 12$

# Unit B

## Suggested Answers and Guidelines

### Inquiry Activity 2 --- Fermat Little Theorem

Fermat's Little theorem is related to a pattern about remainder. In this worksheet, we are going to deduce the theorem.

#### Part I : Introducing a new symbol

If  $a$  and  $b$  have the same remainder when divided by a number  $k$ , we write : '  $a \equiv b \pmod{k}$  '. We call it '  $a$  is congruent to  $b$  modulo  $k$  '.

**E.g.** When 62 is divided by 7, the remainder is 6. When 27 is divided by 7, the remainder is also 6.

So, we write  $62 \equiv 27 \pmod{7}$

#### Practice: True or False

$43 \equiv 27 \pmod{4}$      **True**                       $74 \equiv 27 \pmod{11}$      **False**

$66 \equiv 49 \pmod{3}$      **False**                       $63 \equiv 70 \pmod{7}$      **True**

#### Practice: Fill in the blank with a suitable number

Fill in a number less than 7 on the line:                       $55 \equiv \mathbf{6} \pmod{7}$

Fill in a number less than 10 on the line:                       $123 \equiv \mathbf{3} \pmod{10}$

Fill in a number between 30 and 40 on the line:                       $65 \equiv \mathbf{33} \pmod{8}$

Fill in a number between 30 and 40 on the line:                       $19 \equiv \mathbf{37} \pmod{9}$

#### Part II : Basic Theorem

To look into the Fermat's Theorem, we will first look at some basic theorem about the remainder.

**Theorem 1**     If  $a \equiv b \pmod{k}$  and  $c \equiv d \pmod{k}$ , then  $ac \equiv bd \pmod{k}$

**Examples:**      $17 \equiv 3 \pmod{7}$  and  $9 \equiv 2 \pmod{7}$ , therefore  $17 \times 9 \equiv 3 \times 2 = 6 \pmod{7}$

[ Check:  $17 \times 9 = 153$  | For  $153 \div 7$ , remainder = 6 ]

$23 \equiv 5 \pmod{6}$  and  $19 \equiv 1 \pmod{6}$ , therefore  $23 \times 19 \equiv \mathbf{5 \times 1 = 5} \pmod{6}$

[ Check:  $23 \times 19 = 437$  | For  $437 \div 6$ , remainder = 5 ]

Since  $11 \equiv 5 \pmod{5}$ ,  $19 \equiv 1 \pmod{6}$ ,  $33 \equiv 3 \pmod{6}$ ,

therefore  $11 \times 19 \times 33 \equiv \mathbf{5 \times 1 \times 3 = 3} \pmod{6}$

#### Proof of Theorem 1:

If  $a \equiv b \pmod{k}$ , we can write that  $a - b = kM$ , where  $M$  is an integer.

If  $c \equiv d \pmod{k}$ , we can write that  $c - d = kN$ , where  $N$  is an integer.

$$ac - bd = ac - bc + bc - bd = c(a - b) + b(c - d) = ckM + bkN = k(cM + bN)$$

The expression in the bracket ( $cM + bN$ ) is an integer, therefore  $ac \equiv bd \pmod{k}$

# Unit B

## Suggested Answers and Guidelines

**Theorem 2** Let  $h$  be a number coprime with  $k$ . (Coprime means that  $h$  and  $k$  have no common factor except 1)  
If  $ha \equiv hb \pmod{k}$ , then  $a \equiv b \pmod{k}$ .

**Example:**  $44 \equiv 16 \pmod{7}$

$44$  and  $16$  has a common factor  $4$ , which is coprime with  $7$ .

When we divide  $4$  from both sides, the relation is still true.

$44 \equiv 16 \pmod{7}$     **divide 4**  $\rightarrow$      $11 \equiv 4 \pmod{7}$  is also true.

$65 \equiv 25 \pmod{8}$     **divide 5**  $\rightarrow$      $13 \equiv 5 \pmod{8}$  is also true.

$82 \equiv 10 \pmod{8}$     **divide 2**  $\rightarrow$      $41 \equiv 5 \pmod{8}$  which is a False relation.

Why can't we divide  $2$  from both sides here? **2 and 8 have a common factor 2.**

### Proof of Theorem 2:

Let  $h$  be a number coprime with  $k$ . (Coprime means that  $h$  and  $k$  have no common factor except 1)

If  $ha \equiv hb \pmod{k}$ , then  $ha - hb = kM$ , where  $M$  is an integer.

$\rightarrow h(a - b) = kM$ , this implies  $h$  is a factor of  $kM$

Since  $h$  and  $k$  have no common factor except 1,  $h$  is a factor of  $M$ .

Therefore,  $a - b = k(M/h)$ , where  $M/h$  is an integer.

$\therefore a \equiv b \pmod{k}$ .

**Question :** Is the following true? Explain your answer.

If  $a \equiv b \pmod{k}$  and  $c \equiv d \pmod{k}$ , then  $a + c \equiv b + d \pmod{k}$

If  $a \equiv b \pmod{k}$  and  $c \equiv d \pmod{k}$ , then  $a - b = kM$  and  $c - d = kN$ .

$(a + c) - (b + d) = a - b + c - d = kM + kN = k(M + N)$

$M + N$  is an integer,  $a + c \equiv b + d \pmod{k}$

### Part III: Observation

Fermat's Little Theorem is about a prime number  $p$  and another number  $a$  such that  $a$  and  $p$  are coprime.

E.g.1 Let $p = 5$ and $a = 7$	
Multiple of $a$	Remainder when divided by $p$ (Write a number less than 5)
$1a = 7$	$7 \equiv 2 \pmod{5}$
$2a = 14$	$14 \equiv 4 \pmod{5}$
$3a = 21$	$21 \equiv 1 \pmod{5}$
$4a = 28$	$28 \equiv 3 \pmod{5}$

E.g.2 Let $p = 5$ and $a = 13$	
Multiple of $a$	Remainder when divided by $p$ (Write a number less than 5)
$1a = 13$	$13 \equiv 3 \pmod{5}$
$2a = 26$	$26 \equiv 1 \pmod{5}$
$3a = 39$	$39 \equiv 4 \pmod{5}$
$4a = 52$	$52 \equiv 2 \pmod{5}$

### Observation:

When  $p = 5$ , the first 4 multiple of  $a$  gives the reminders: 1, 2, 3, 4 when divided by  $p$ .

# Unit B

## Suggested Answers and Guidelines

E.g.3 Let $p = 7$ and $a = 3$	
Multiple of $a$	Remainder when divided by $p$ (Write a number less than 7)
$1a = 3$	$3 \equiv 3 \pmod{7}$
$2a = 6$	$6 \equiv 6 \pmod{7}$
$3a = 9$	$9 \equiv 2 \pmod{7}$
$4a = 12$	$12 \equiv 5 \pmod{7}$
$5a = 15$	$15 \equiv 1 \pmod{7}$
$6a = 18$	$18 \equiv 4 \pmod{7}$

E.g.4 Let $p = 7$ and $a = 11$	
Multiple of $a$	Remainder when divided by $p$ (Write a number less than 7)
$1a = 11$	$11 \equiv 4 \pmod{7}$
$2a = 22$	$22 \equiv 1 \pmod{7}$
$3a = 33$	$33 \equiv 5 \pmod{7}$
$4a = 44$	$44 \equiv 2 \pmod{7}$
$5a = 55$	$55 \equiv 6 \pmod{7}$
$6a = 66$	$66 \equiv 3 \pmod{7}$

### Observation:

When  $p = 7$ , the first 6 multiple of  $a$  gives the remainders: 1, 2, 3, 4, 5, 6 when divided by  $p$ .

### Part IV : Apply the theorem

The first  $(p - 1)$  multiples of  $a$ :  $a, 2a, 3a, \dots, (p-1)a$  gives the remainders  $1, 2, 3, \dots, p-1$  when they are divided by  $p$ .

By Theorem 1, we can multiply them together and give the relation:

$$(a)(2a)(3a) \dots [(p-1)a] \equiv 1 \times 2 \times 3 \times \dots \times (p-1) \pmod{p}$$

$$1 \times 2 \times 3 \dots \times (p-1) \times a^{p-1} \equiv 1 \times 2 \times 3 \times \dots \times (p-1) \pmod{p}$$

Since  $1 \times 2 \times 3 \dots \times (p-1)$  and  $p$  has no common factor.

By Theorem 2,  $a^{p-1} \equiv 1 \pmod{p}$

### Conclusion: Fermat's Little Theorem

If  $p$  is a prime number and  $a$  is coprime with  $p$ , then  $a^{p-1} \equiv 1 \pmod{p}$

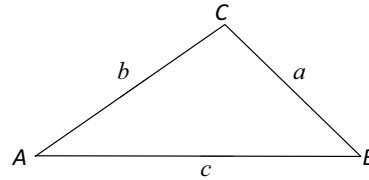
# Unit C

## Pre-lesson Worksheet 3

### Sine Formula

Given a triangle  $ABC$ , let  $a = BC$ ,  $b = AC$ ,  $c = AB$ . There is a nice relationship between the sides and angles:

$$\frac{a}{\sin A} = \frac{b}{\sin B} = \frac{c}{\sin C}$$



*Proof* Let  $D$  be a point on  $AB$  such that  $CD \perp AB$ .

Let  $h = AD$ . Then, in  $\triangle ACD$ , we have

$$\sin A = \frac{h}{b}$$

$$h = \frac{b \sin A}{1}$$

In  $\triangle BCD$ , we have

$$\sin B = \frac{h}{a}$$

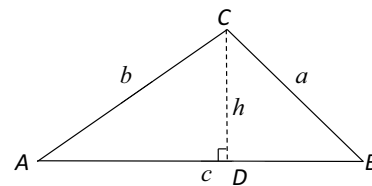
$$h = \frac{a \sin B}{1}$$

Hence comparing the two expressions of  $h$ ,

$$\frac{b \sin A}{1} = \frac{a \sin B}{1}$$

$$\frac{a}{\sin A} = \frac{b}{\sin B}$$

Similarly, we have  $\frac{a}{\sin A} = \frac{b}{\sin B} = \frac{c}{\sin C}$ .



### Exercise

Find the angles  $A$  and  $C$ , and the side  $AB$ , using the sine law.

To find  $A$ ,

$$\frac{10}{\sin A} = \frac{8}{\sin 30^\circ}$$

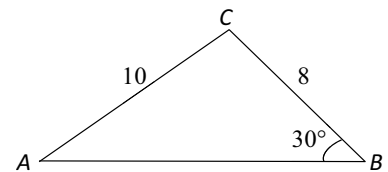
$$\sin A = \frac{8 \sin 30^\circ}{10}$$

$$A = \sin^{-1}\left(\frac{8 \sin 30^\circ}{10}\right)$$

$$\text{Then, } C = 180^\circ - 30^\circ - A = 150^\circ - A$$

To find  $AB$ ,

$$\frac{c}{\sin C} = \frac{8}{\sin 30^\circ}$$



# Unit C

## Pre-lesson Worksheet 3

### Area formula for a triangle

From the proof of the sine law, we can deduce a useful formula for computing the area of a triangle, namely:

$$\text{Area of } \triangle ABC = \frac{1}{2}ab\sin C = \frac{1}{2}bc\sin A = \frac{1}{2}ac\sin B$$

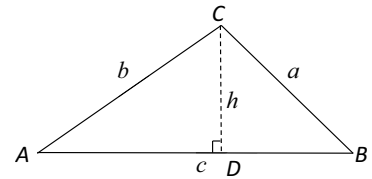
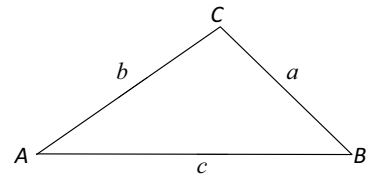
*Proof* With the setup from the proof of sine law, we can deduce from  $\triangle ACD$  that

$$h = \text{_____} \quad (\text{express in terms of } b \text{ and angle } A)$$

Hence the area of  $\triangle ABC$

$$= \frac{1}{2} \times AB \times CD = \frac{1}{2}ch = \text{_____} = \frac{1}{2}bc\sin A$$

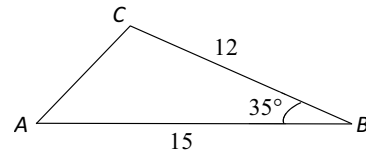
The other two forming the area can be proved similarly.



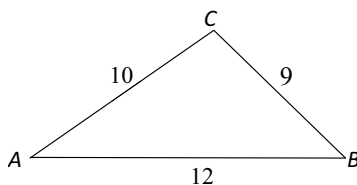
(end of proof)

### Exercise

Find the area of  $\triangle ABC$  in the figure.



**Think:** If the three sides of a triangle are given, but none of the angles are given, can you still find the angles?



# Unit C

## Lesson Worksheet 3

### Cosine Formula

#### Task 1: Proof of Cosine Formula using Coordinate Geometry

##### Distance Formula

Given two points  $(x_1, y_1)$  and  $(x_2, y_2)$  in a coordinate.

The distance between the points is given by the formula

$$AB = \sqrt{(x_2 - x_1)^2 + (y_2 - y_1)^2}$$

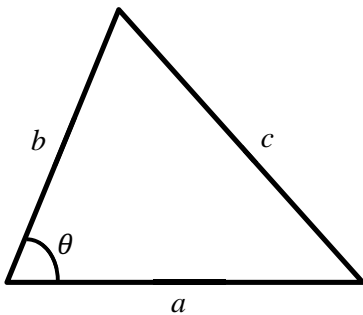
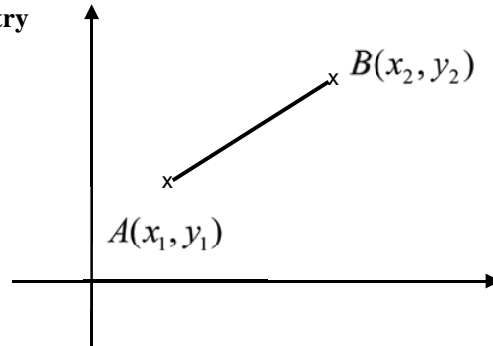


Fig. 1a

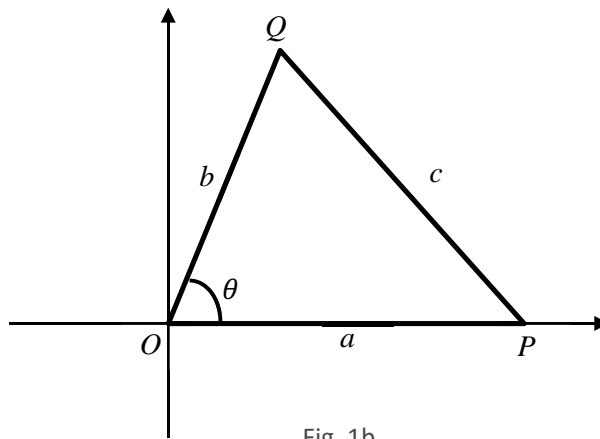


Fig. 1b

Fig. 1a shows a triangle with sides of length  $a$ ,  $b$ ,  $c$  and  $\theta$ , the angle is opposite the side  $c$ .

This triangle is placed on a rectangular coordinate plane as shown in Fig. 1b.

$O$  is the origin and the coordinates of  $P$  are  $(a, 0)$ .

- Express the coordinate of  $Q$  in terms of  $b$  and  $\theta$ .

$$Q( \quad , \quad )$$

- By the distance formula,

$$c =$$

Square and expand both sides of the equation :

$$c^2 =$$

# Unit C

## Lesson Worksheet 3

3. Does the proof work for the case when  $\theta$  is an obtuse angle (See Fig. 2)? Explain your answer.

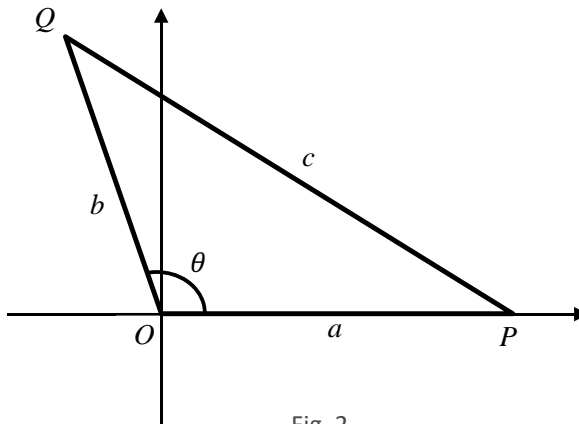


Fig. 2

### Task 2: Using trigonometry

Fill in the details of the proof based on Fig. 3

Drop the perpendicular onto the side  $c$ ,

$$c = \underline{\hspace{2cm}} + \underline{\hspace{2cm}}$$

Multiply both sides by  $c$  to get

$$c^2 = \underline{\hspace{2cm}}$$

By considering the other perpendiculars, we can obtain

$$a^2 = \underline{\hspace{2cm}},$$

$$b^2 = \underline{\hspace{2cm}}$$

Adding the latter two equations gives

$$a^2 + b^2 = \underline{\hspace{2cm}}$$

Subtracting the first equation from the last one we have

$$a^2 + b^2 - c^2 = \underline{\hspace{2cm}}$$

which simplifies to

$$c^2 = \underline{\hspace{2cm}}$$

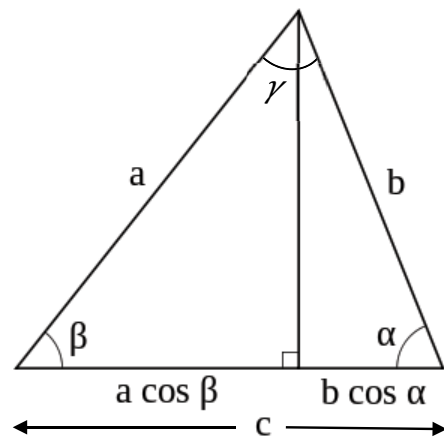


Fig. 3



# Unit C

## Lesson Worksheet 3

### Task 3: Using the Pythagorean theorem

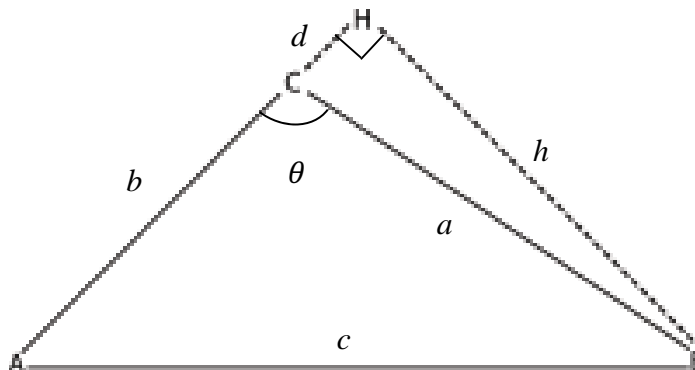


Fig. 4a – Obtuse triangle  $ABC$  with height  $BH$

#### Case of an obtuse angle

Using  $d$  to denote the line segment  $CH$  and  $h$  for the height  $BH$ , triangle  $AHB$  gives us

$$c^2 = \underline{\hspace{2cm}}$$

and triangle  $CHB$  gives

$$a^2 = \underline{\hspace{2cm}}$$

Expanding the first equation gives

$$c^2 =$$

Substituting the second equation into this, the following can be obtained:

$$c^2 = \hspace{10em} \text{(in terms of } a, b \text{ and } d)$$

Note that  $d = a \cos(180^\circ - \gamma) = -a \cos \gamma$

# Unit C

## Lesson Worksheet 3

### Case of an acute angle

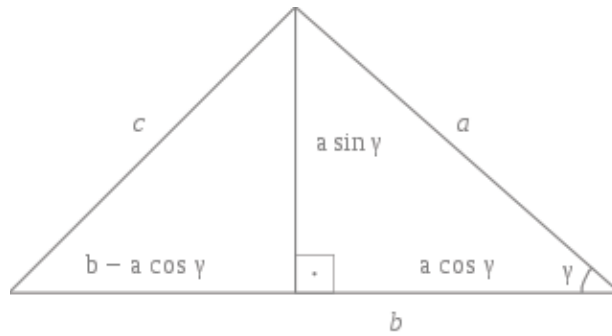


Fig. 4b – A short proof using trigonometry for the case of an acute angle

### Case of an acute case

Using more trigonometry, the Cosine Formula can be deduced by using the Pythagorean theorem only *once*. In fact, by using the right triangle on the left hand side of Fig. 4 it can be shown that:

$$c^2 = ( \quad )^2 + ( \quad )^2$$

If  $b < a \cos \gamma$ , how will you modify the above proof?

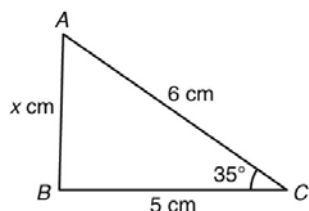
# Unit C

## Lesson Worksheet 4

### Cosine Formula

**Practice on Cosine Formula** (Give your answers correct to 3 significant figures.)

1. Find  $x$ .

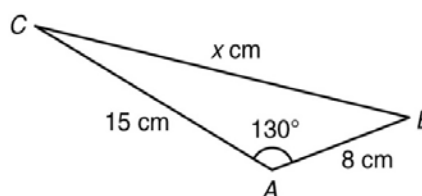


By the cosine formula,

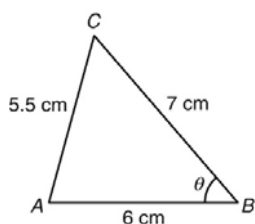
$$x^2 = ( \quad )^2 + ( \quad )^2 - 2( \quad )( \quad ) \cos( \quad )$$

$$x =$$

2. Find  $x$ .



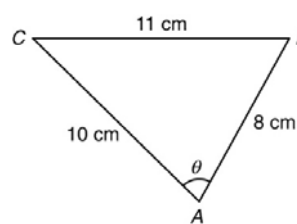
3. Find  $\theta$ .



By the cosine formula,

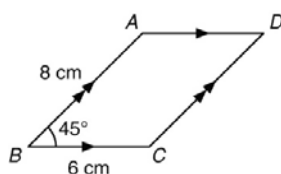
$$\cos \theta = \frac{( \quad )^2 + ( \quad )^2 - ( \quad )^2}{2( \quad )( \quad )}$$

4. Find  $\theta$ .

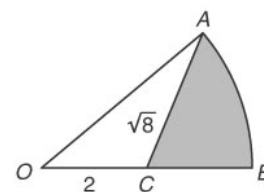


### Harder Questions

5. In the figure,  $ABCD$  is a parallelogram. Find the length of the diagonal  $BD$ .



6.  $OAB$  is a sector of a circle with centre  $O$ .  $C$  is the midpoint of  $OB$  such that  $CA = \sqrt{8}$  and  $OC = 2$ . Find  
 (a)  $\angle AOB$ ,  
 (b) the area of the shaded region.



# Unit C

## Extension Worksheet

### Extension – Prove Cosine Formula ( $c^2 = a^2 + b^2 - 2ab \cos C$ ) by Sine Formula

To prepare for the proof, we will need a few more formula and identities.

1.  $\sin(A+B) = \sin A \cos B + \cos B \sin A$

You can find two different proofs in the following videos.

Proof using Area Formula <a href="https://youtu.be/qznBmRIYUB4">https://youtu.be/qznBmRIYUB4</a>	Proof by Length Relations <a href="https://youtu.be/nt0Nfz5Lc0A">https://youtu.be/nt0Nfz5Lc0A</a>
---	--

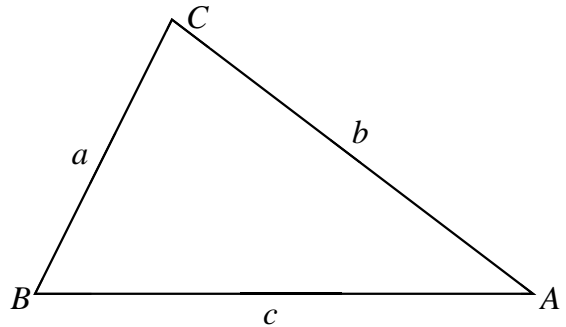
2.  $\sin(180 - \theta) = \sin \theta$

This formula is due to the definition of  $\sin \theta$  for  $90^\circ < \theta < 180^\circ$ , which will be learnt in S.4.

### Proof of Cosine Formula using Sine Formula

By the Sine Formula, we have

$$\frac{a}{\sin A} = \frac{c}{\sin C} \quad \text{and} \quad \frac{a}{\sin A} = \frac{b}{\sin B}$$
$$a \sin C = c \sin A \quad \text{and} \quad a \sin B = b \sin A$$



By the angle sum of triangle ,

$$B = 180^\circ - A - C = 180 - (A + C)$$

Using the formula from the previous page,

$$\begin{aligned} \sin B &= \sin(180^\circ - (A + C)) \\ &= \sin(A + C) \\ &= \sin A \cos C + \cos A \sin C \end{aligned}$$

Substitute into  $a \sin B = b \sin A$  and using  $a \sin C = c \sin A$

$$\begin{aligned} a(\sin A \cos C + \cos A \sin C) &= b \sin A \\ a \sin A \cos C + (a \sin C) \cos A &= b \sin A \end{aligned}$$

Fill in the steps to change the subject to  $c$  as given.

$$c = \frac{b - a \cos C}{\cos A}$$

Think: How to continue and obtain  $c^2 = a^2 + b^2 - 2ab \cos C$  ?

Try it before looking at the solution at the back.

## Unit C

### Extension Worksheet

Square both sides,

$$c^2 = \frac{(b - a \cos C)^2}{\cos^2 A}$$

$$c^2 \cos^2 A = b^2 - 2ab \cos C + a^2 \cos^2 C$$

$$c^2 (1 - \sin^2 A) = b^2 - 2ab \cos C + a^2 \cos^2 C$$

$$c^2 - c^2 \sin^2 A = b^2 - 2ab \cos C + a^2 \cos^2 C$$

Substitute  $a \sin C = c \sin A$  into it,

$$c^2 - a^2 \sin^2 C = b^2 - 2ab \cos C + a^2 \cos^2 C$$

$$c^2 = b^2 - 2ab \cos C + a^2 (\cos^2 C + \sin^2 C)$$

$$c^2 = b^2 - 2ab \cos C + a^2$$

$$c^2 = a^2 + b^2 - 2ab \cos C$$

(Steps for changing subject in the previous page.)

$$a(\sin A \cos C + \cos A \sin C) = b \sin A$$

$$a \sin A \cos C + (a \sin C) \cos A = b \sin A$$

Substitute  $a \sin C = c \sin A$  into it,

$$a \sin A \cos C + (c \sin A) \cos A = b \sin A$$

$$a \cos C + c \cos A = b$$

$$c = \frac{b - a \cos C}{\cos A}$$

# Unit C

## Suggested Answers and Guidelines

### Suggested Answers and Guidelines for Unit C

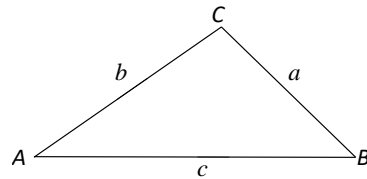
#### Pre-lesson Worksheet 3

### Cosine Formula

#### Sine Formula

Given a triangle  $ABC$ , let  $a = BC$ ,  $b = AC$ ,  $c = AB$ . There is a nice relationship between the sides and angles:

$$\frac{a}{\sin A} = \frac{b}{\sin B} = \frac{c}{\sin C}$$



*Proof* Let  $D$  be a point on  $AB$  such that  $CD \perp AB$ .

Let  $h = CD$ . Then, in  $\triangle ACD$ , we have

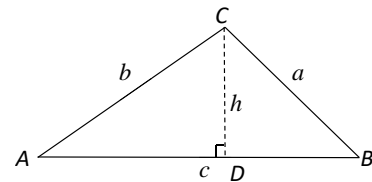
$$\sin A = \frac{h}{b}$$

$$h = b \sin A$$

In  $\triangle BCD$ , we have

$$\sin B = \frac{h}{a}$$

$$h = a \sin B$$



Hence comparing the two expressions of  $h$ ,

$$a \sin B = b \sin A$$

$$\frac{a}{\sin A} = \frac{b}{\sin B}$$

Similarly, we have  $\frac{a}{\sin A} = \frac{b}{\sin B} = \frac{c}{\sin C}$ .

#### Exercise

Find the angles  $A$  and  $C$ , and the side  $AB$ , using the sine law.

[Ans:  $A = 23.6^\circ$ ,  $C = 126^\circ$ ,  $AB = 16.1$ ]

To find  $A$ ,

$$126.4218215^\circ$$

$$\frac{8}{\sin A} = \frac{10}{\sin 30^\circ}$$

$$\sin A = \frac{8 \sin 30^\circ}{10}$$

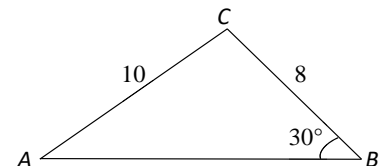
$$A = 23.57817848^\circ$$

Then,  $C = 180^\circ - 30^\circ - A =$

To find  $AB$ ,

$$\frac{AB}{\sin 126.4218215^\circ} = \frac{10}{\sin 30^\circ}$$

$$AB = 16.09335462$$



# Unit C

## Suggested Answers and Guidelines

### Area formula for a triangle

From the proof of the sine law, we can deduce a useful formula for computing the area of a triangle, namely:

$$\text{Area of } \triangle ABC = \frac{1}{2}ab \sin C = \frac{1}{2}bc \sin A = \frac{1}{2}ac \sin B$$

*Proof* With the setup from the proof of sine law, we can deduce from  $\triangle ACD$  that

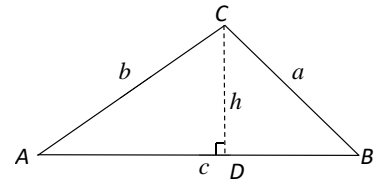
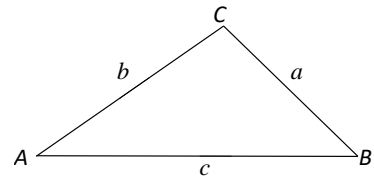
$$h = b \sin A \quad (\text{express in terms of } b \text{ and angle } A)$$

Hence the area of  $\triangle ABC$

$$= \frac{1}{2} \times AB \times CD = \frac{1}{2}ch = \frac{1}{2}c(b \sin A) = \frac{1}{2}bc \sin A$$

The other two forming the area can be proved similarly.

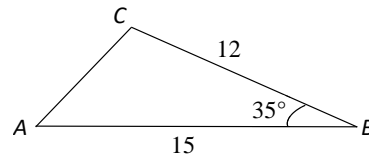
(end of proof)



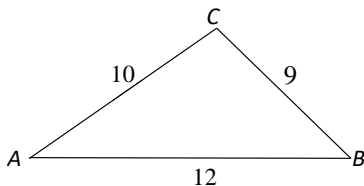
### Exercise

Find the area of  $\triangle ABC$  in the figure. [Ans: 51.6]

$$\text{Area} = \frac{1}{2}(12)(15) \sin 35^\circ = 51.6$$



**Think:** If the three sides of a triangle are given, but none of the angles are given, can you still find the angles?



# Unit C

## Suggested Answers and Guidelines

### Lesson Worksheet 3

#### Task 1: Proof of Cosine Formula using Coordinate Geometry Distance Formula

Given two points  $(x_1, y_1)$  and  $(x_2, y_2)$  in a coordinate.

The distance between the points is given by the formula

$$AB = \sqrt{(x_2 - x_1)^2 + (y_2 - y_1)^2}$$

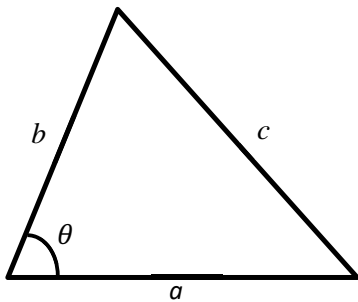
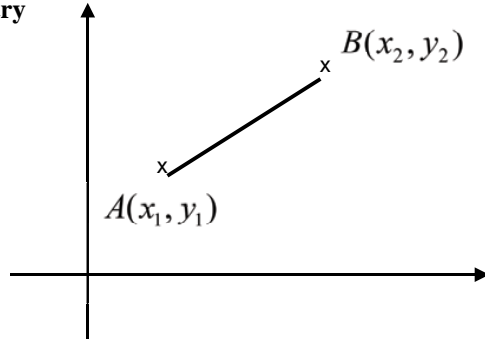


Fig. 1a

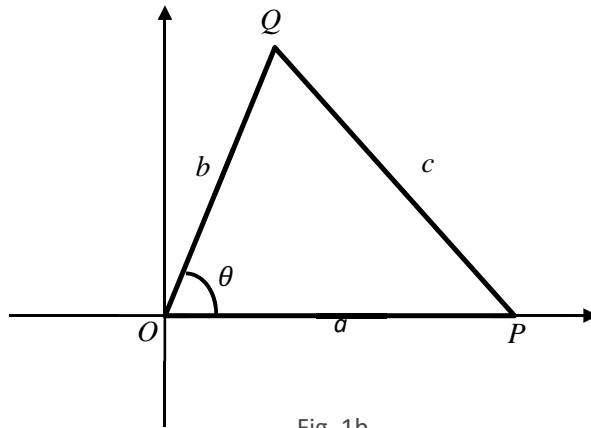


Fig. 1b

Fig. 1a shows a triangle with sides  $a$ ,  $b$  and  $c$ , with the angle  $\theta$  is opposite to side  $c$ .

This triangle is placed on a rectangular coordinate plane as shown in Fig. 1b.

$O$  is the origin and the coordinates of  $P$  are  $(a, 0)$ .

1. Express the coordinate of  $Q$  in terms of  $b$  and  $\theta$ .

$$Q = (b \cos \theta, b \sin \theta)$$

2. By the distance formula,

$$c = \sqrt{(a - b \cos \theta)^2 + (0 - b \sin \theta)^2}$$

Square and expand both sides of the equation :

$$c^2 = (a - b \cos \theta)^2 + (-b \sin \theta)^2$$

$$c^2 = a^2 - 2ab \cos \theta + b^2 \cos^2 \theta + b^2 \sin^2 \theta$$

$$c^2 = a^2 + b^2 (\cos^2 \theta + \sin^2 \theta) - 2ab \cos \theta$$

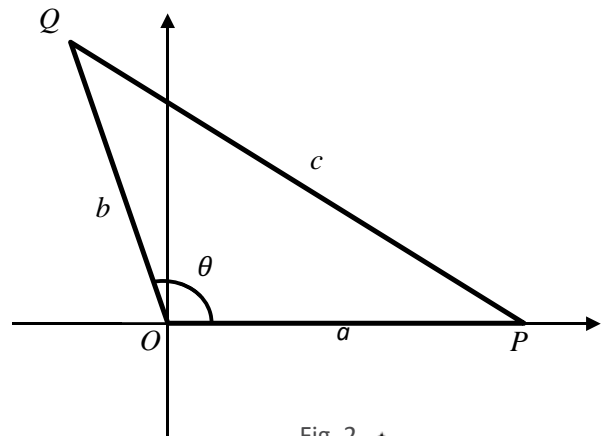
$$c^2 = a^2 + b^2 - 2ab \cos \theta$$



# Unit C

## Suggested Answers and Guidelines

Yes, under the definition of trigonometric function of general angle. The proof works even when  $\theta$  is an obtuse angle as the coordinates of  $Q$  is still  $(b \cos \theta, b \sin \theta)$ .



### Task 2: Using trigonometry

Fill in the details of the proof based on Fig. 3

Drop the perpendicular onto the side  $c$ ,

$$c = \text{_____} + \text{_____}$$

$$c = a \cos \beta + b \cos \alpha$$

Multiply through by  $c$  to get

$$c^2 = ac \cos \beta + bc \cos \alpha$$

By considering the other perpendiculars, it obtains

$$a^2 = ac \cos \beta + ab \cos \gamma,$$

$$b^2 = bc \cos \alpha + ab \cos \gamma$$

Adding the latter two equations gives

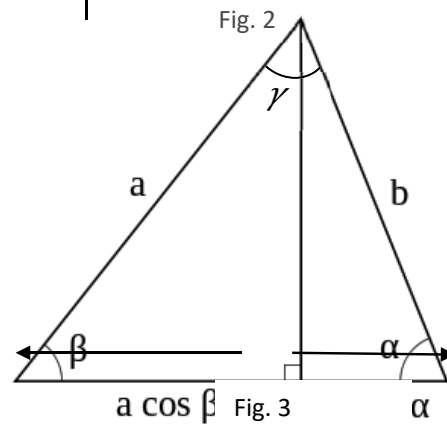
$$a^2 + b^2 = ac \cos \beta + bc \cos \alpha + 2ab \cos \gamma$$

Subtracting the first equation from the last one we have

$$a^2 + b^2 - c^2 = -ac \cos \beta - bc \cos \alpha + ac \cos \beta + bc \cos \alpha + 2ab \cos \gamma$$

which simplifies to

$$c^2 = a^2 + b^2 - 2ab \cos \gamma$$



## Unit C

### Suggested Answers and Guidelines

#### Task 3: Using the Pythagorean theorem

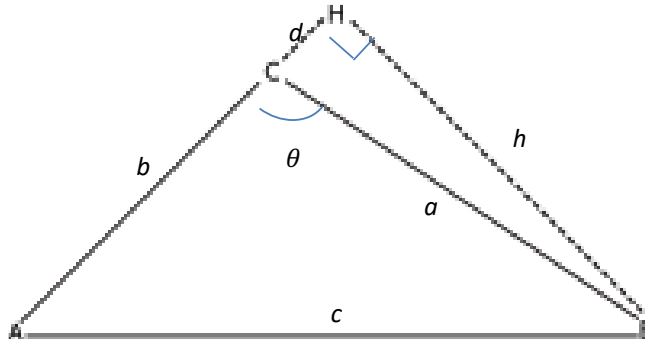


Fig. 4a – Obtuse triangle  $ABC$  with height  $BH$

#### Case of an obtuse angle

Using  $d$  to denote the line segment  $CH$  and  $h$  for the height  $BH$ , triangle  $AHB$  gives us

$$c^2 = (b + d)^2 + h^2$$

and triangle  $CHB$  gives

$$d^2 + h^2 = a^2$$

Expanding the first equation gives

$$c^2 = b^2 + 2bd + d^2 + h^2$$

Substituting the second equation into this, the following can be obtained:

$$c^2 = a^2 + b^2 + 2bd$$

Note that  $d = a \cos(180^\circ - \gamma) = -a \cos \gamma$

## Unit C

### Suggested Answers and Guidelines

#### Case of an acute angle

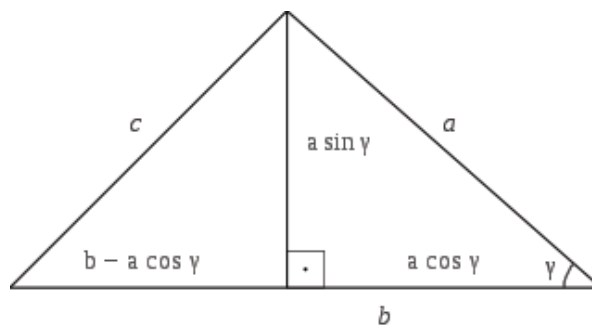


Fig. 4b – A short proof using trigonometry for the case of an acute angle

#### Another proof in the acute case

Using more trigonometry, the Cosine Formula can be deduced by using the Pythagorean theorem only *once*. In fact, by using the right triangle on the left hand side of Fig. 4 it can be shown that:

$$\begin{aligned}c^2 &= (b - a \cos \gamma)^2 + (a \sin \gamma)^2 \\&= b^2 - 2ab \cos \gamma + a^2 \cos^2 \gamma + a^2 \sin^2 \gamma \\&= b^2 + a^2 - 2ab \cos \gamma,\end{aligned}$$

If  $b < a \cos \gamma$ , how will you modify the above proof?

In this case, the right triangle to which the Pythagorean theorem is applied moves *outside* the triangle  $ABC$ . The only effect on the calculation is that the quantity  $b - a \cos \gamma$  is replaced by  $a \cos \gamma - b$ . As this quantity enters the calculation only through its square, the rest of the proof is unaffected. However, this problem only occurs when  $\beta$  is obtuse, and may be avoided by reflecting the triangle about the bisector of  $\gamma$ .

# Unit C

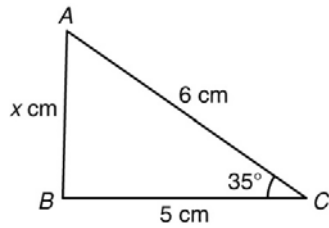
## Suggested Answers and Guidelines

### Lesson Worksheet 4

### Cosine Formula

**Practice on Cosine Formula** (Give your answers correct to 3 significant figures.)

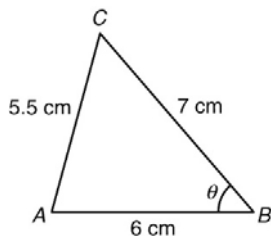
1. Find  $x$ .



By the cosine formula,

$$x^2 = 5^2 + 6^2 - 2(5)(6)\cos 35^\circ$$
$$x = 3.44$$

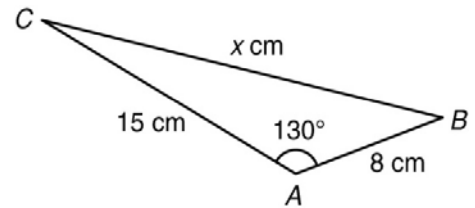
3. Find  $\theta$ .



By the cosine formula,

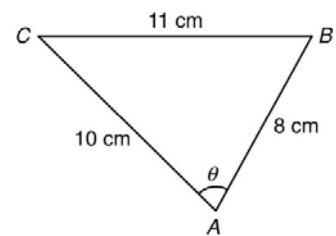
$$\cos \theta = \frac{6^2 + 7^2 - 5.5^2}{2(6)(7)}$$
$$\theta = 49.3^\circ$$

2. Find  $x$ .



$$x^2 = 15^2 + 8^2 - 2(15)(8)\cos 130^\circ$$
$$x = 21.1$$

4. Find  $\theta$ .



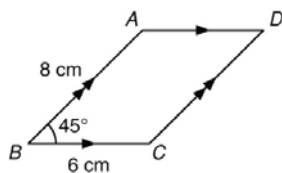
$$\cos \theta = \frac{8^2 + 10^2 - 11^2}{2(8)(10)}$$
$$\theta = 74.4^\circ$$

# Unit C

## Suggested Answers and Guidelines

### Harder Questions

5. In the figure,  $ABCD$  is a parallelogram. Find the length of the diagonal  $BD$ .

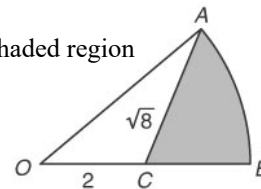


$$\angle A = 180^\circ - 45^\circ = 135^\circ$$

$$BD^2 = 6^2 + 8^2 - 2(6)(8)\cos 135^\circ$$

$$BD = 13.0$$

6.  $OAB$  is a sector of a circle with centre  $O$ .  $C$  is the mid-point of  $OB$  such that  $CA = \sqrt{8}$  and  $OC = 2$ . Find
- $\angle AOB$ ,
  - the area of the shaded region



$$BC = 2, OA = 4$$

$$\cos \angle AOC = \frac{2^2 + 4^2 - (\sqrt{8})^2}{2(2)(4)}$$

$$\angle AOC = 41.40962211^\circ$$

$$\begin{aligned} \text{Area} &= \pi(4^2) \frac{41.40962211^\circ}{360^\circ} - \frac{1}{2}(2)(4)\sin 41.40962211^\circ \\ &= 3.14 \end{aligned}$$

# Unit C

## Origami Materials

### Unit C      Cosine Formula      Origami Materials

We can also prove the Cosine Formula by calculating areas. The change of sign as the angle  $\gamma$  becoming obtuse makes a case distinction necessary.

Recall that  $a^2$ ,  $b^2$  and  $c^2$  are the areas of the squares with sides  $a$ ,  $b$  and  $c$  respectively;

- if  $\gamma$  is acute, then  $ab \cos \gamma$  is the area of the parallelogram with sides  $a$  and  $b$  forming an angle of  $\gamma' = 90^\circ - \gamma$  ;
- if  $\gamma$  is obtuse, and so  $\cos \gamma$  is negative, then  $-ab \cos \gamma$  is the area of the parallelogram with sides  $a$  and  $b$  forming an angle of  $\gamma' = \gamma - 90^\circ$ .

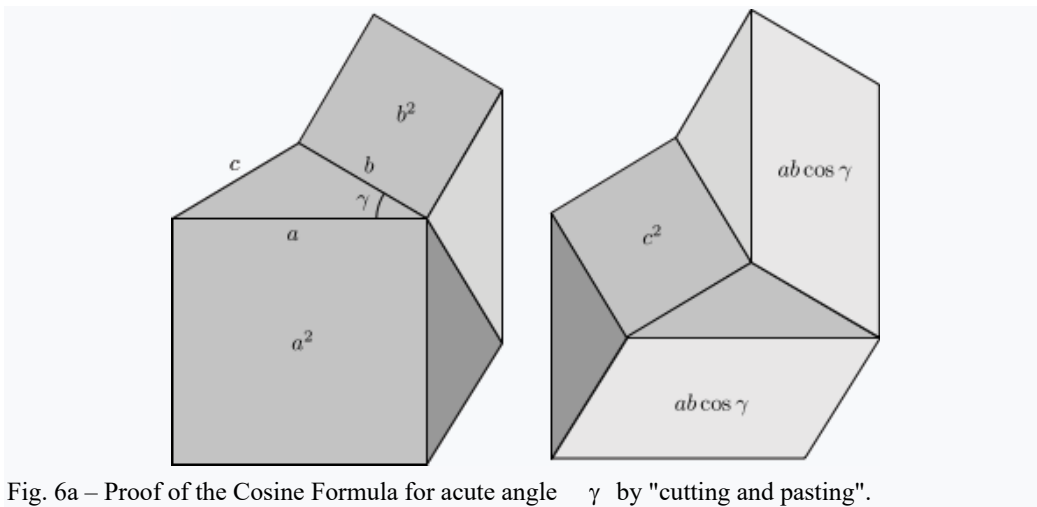


Fig. 6a – Proof of the Cosine Formula for acute angle  $\gamma$  by "cutting and pasting".

**Acute case.** Figure 6a shows a heptagon cutting into smaller pieces (in two different ways) to yield a proof of the Cosine Formula. The various pieces are

- in pink, the areas  $a^2$ ,  $b^2$  on the left and the areas  $2ab \cos \gamma$  and  $c^2$  on the right;
- in blue, the triangle  $ABC$ , on the left and on the right;
- in grey, auxiliary triangles, all congruent to  $ABC$ , an equal number (namely 2) both on the left and on the right.

The equality of areas on the left and on the right gives

$$a^2 + b^2 = c^2 + 2ac \cos \gamma$$

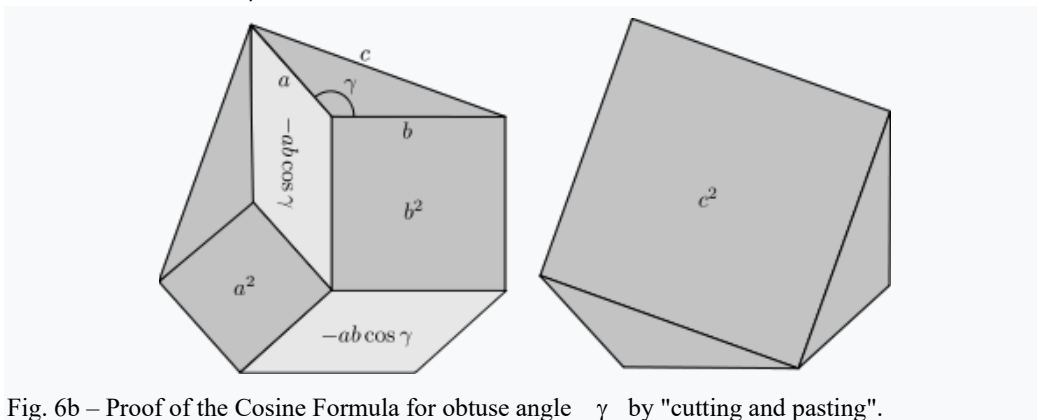


Fig. 6b – Proof of the Cosine Formula for obtuse angle  $\gamma$  by "cutting and pasting".

# Unit C

## Origami Materials

**Obtuse case.** Figure 6b cuts a hexagon in two different ways into smaller pieces, yielding a proof of the Cosine Formula in the case that the angle  $\gamma$  is obtuse. We have

- in pink, the areas  $a^2$ ,  $b^2$  and  $-2ab \cos \gamma$  on the left and  $c^2$  on the right;
- in blue, the triangle  $ABC$  twice, on the left, as well as on the right.

The equality of areas on the left and on the right gives

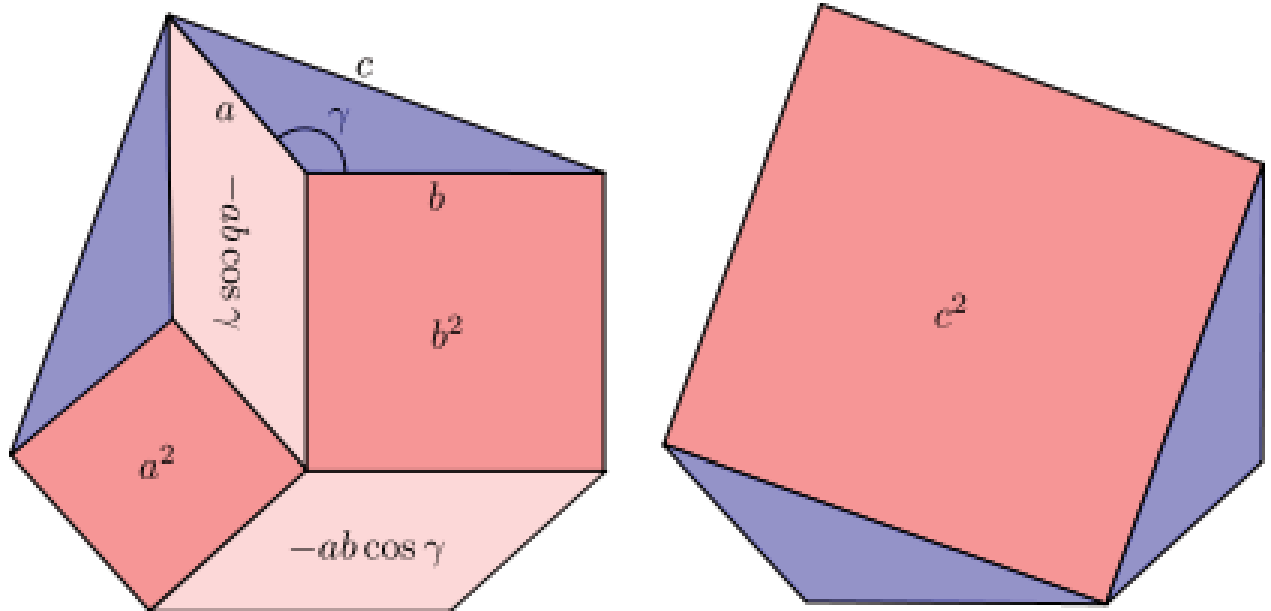
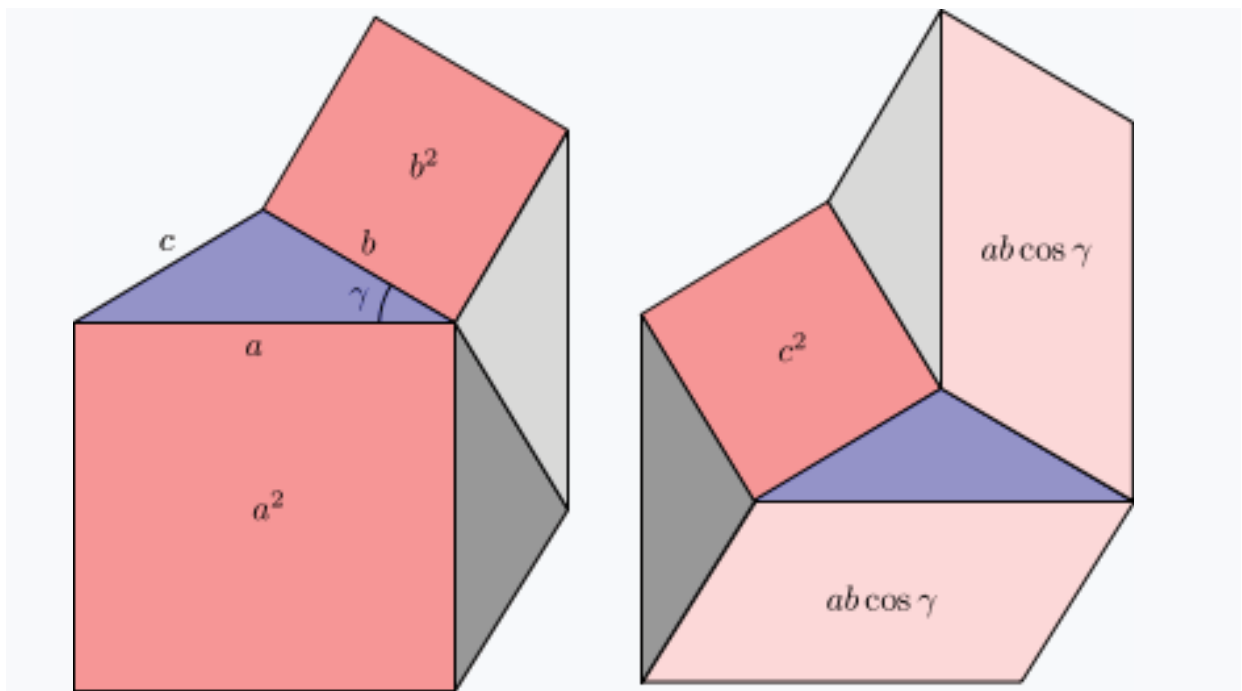
$$a^2 + b^2 - 2ac \cos \gamma = c^2$$

The rigorous proof will have to include proofs that various shapes are congruent and therefore they have equal area. This will use the theory of congruent triangles (to proof?).

Reference: [https://en.wikipedia.org/wiki/Law\\_of\\_cosines](https://en.wikipedia.org/wiki/Law_of_cosines)

# Unit C

## Origami Materials





# Isoperimetric Problem

**Grade: Secondary 2**

**No. of Lessons (Learning Time): 7 Units (60 -75 minutes for each unit) + 1 Extension Unit**

<b>Operation Mode of Gifted Education</b>	Level 2: School-based Pull-out Programme
<b>Target Students</b>	<ul style="list-style-type: none"> <li>- S2 students with outstanding performance, rigorous reasoning skills and high comprehension power in Mathematics</li> <li>- Students having a strong interest in Mathematics, for the extension of learning after school and pull-out class</li> <li>- Students having a strong task commitment in Mathematics, for the high perseverance in solving challenging problems</li> </ul>

## Foreword / Background

When teaching the topic “Area and Perimeter” in the S1 curriculum, teachers had introduced the following results using computer simulation: when the perimeter of a n-sided polygon is fixed, the polygon attains its maximum area when it is a regular polygon. However, the proof or the reason behind was not discussed in the lesson as it involved advanced content knowledge and proving skills not yet learnt by most students. Such knowledge and skills are excellent elements for a pull-out programme, which aims to provide enrichment knowledge and training of thinking skills for students with outstanding performance and strong interest in Mathematics.

The Project School has a tradition in which the S2 Mathematics pull-out programme is led by a few student instructors studying in S5 in the school. At the beginning of this programme, the teacher-in-charge discussed and designed the course content with the Project GIFT team and developed the learning materials. Student instructors then studied the materials to gain understanding and to think of guiding questions for the S2 participants. Student instructors were also responsible for teaching the pull-out class with some support from the teacher-in-charge. The teacher had a discussion with student instructors after each lesson to help them reflect and improve their teaching performance and confidence.

## Objectives of Collaboration

The aim of the collaboration was to develop a pull-out gifted Mathematics programme which can serve as an extension of the regular curriculum. The programme provides a detailed discussion of

the solution to the Isoperimetric Problem, a well-known Mathematical problem with a long history. The solution is broken down into a lot of short propositions to be proved. Through proving these propositions, a wide range of Mathematical thinking and proving skills, such as generalization and proof by contradiction, can be introduced to students. In order to prove the propositions, students will also need to attain Mathematical knowledge above their level.

S2 students are expected to gain a deeper understanding in Mathematics and develop their higher-order thinking skills, especially the skills of constructing different types of Mathematical proofs and giving judgements with rigorous reasoning. Through discussion, presenting their solutions and challenging others' solutions, students can develop social and presentation skills. Students can also get used to comprehending materials of advanced levels and gain better self-learning ability.

S5 student instructors can also benefit from the programme. They need to comprehend unfamiliar Mathematics content knowledge. When preparing and conducting the lesson, they may need to convert the given reading materials into an interactive lesson which is rich in questions and discussions. They gain valuable experience of teaching Mathematics, which strengthens their personal-social competence and leadership skills. Moreover, to manage the extra workload as an instructor, they are expected to develop better time-management skills. All these skills are important for their future careers.

## Student Selection Criteria and Procedures

Teachers were advised to adopt multiple approaches to select students. Beside looking at results in Mathematics examinations and competitions, a short screening test was also given to all S2 students. Questions in the screening test involved non-routine problems selected from Mathematics competitions to better assess students' problem solving ability. Previously, students' logical reasoning ability had been assessed with the help of Project GIFT. These test results could be reviewed during the selection process. Furthermore, Mathematics teachers of each S2 class could nominate students based on their observation in the lesson. Finally, there were also opportunities for students to nominate themselves and join the programme.

## Theoretical Framework

Gavin and Sheffield outlined four components that characterize an advanced and in-depth curriculum appropriate for gifted Mathematics students (Gavin, 2016):

1. Creative and complex problem-solving
2. Connections within and across Mathematical and other content areas and across a wide range of contexts
3. An inquiry-based approach that focuses on processes used by Mathematicians
4. Appropriate pacing

An advanced and in-depth curriculum should involve both above-grade-level content knowledge and deep Mathematical investigations that are challenging for gifted students. Creative and complex problems refer to those problems that require students to think at high levels, to test out ideas, to discuss ideas and to demonstrate their reasoning skills. Through an inquiry-based approach, students are encouraged to explore and discover Mathematics knowledge. In a gifted programme, an appropriate pacing is to keep repetition and practice at a minimum when introducing new materials and provide enough time to discuss, struggle and reflect during investigation and problem-solving.

Proof and proving can deepen Mathematical understanding and broaden reasoning skills. Mathematical proof consists of not only a sequence of steps following formal notation and rules, but also a sequence of ideas and insights (Hanna & Villiers, 2008). Through studying and writing Mathematical proofs, students practice building a sequence of logical steps and applying Mathematical ideas they have known to construct arguments. These processes help students to achieve Mathematical understanding (Hanna & Mason, 2014). Thus, proof and proving is an important theme in Mathematics and the nature of Mathematical proof also coincides with the advanced and in-depth curriculum for gifted Mathematics students.

## Learning and Teaching Strategies

A peer tutoring approach has been the established practice of the school over the years. In each lesson, student instructors take turns to lead the discussion with the participating students. Besides, they also walk through each group of participants and provide hints to them. With suitable guidance and supervision from teachers, the approach can provide a platform for exchanging and building up Mathematical knowledge among junior and senior form students. Leadership skills of the instructors are also utilized when taking a teacher's role in the programme.

In the first two units, content knowledge about trigonometry, area formula of triangles and the method of completing the squares are introduced to students through direct demonstration by student instructors or the teacher. Most of this content can be found in S3 and S4 Mathematics textbooks. A suitable approach to teach such knowledge is to keep drilling practice at a minimum and to spend much time delivering the reasoning behind the proofs of the formula.

In the next five units, students are given pre-lesson materials to encourage self-learning and to equip them with the knowledge necessary for the lesson. In the lesson, they are given a few problem-solving tasks which require students to prove or disprove a statement. Students work in groups to discuss and solve the problems. Student instructors provide hints and guiding questions (See Lesson Worksheets) from time to time to help students. The approach follows the theoretical framework that the pull-out programme should involve complex problem-solving and an inquiry-based approach. Finally, student instructors help summarize the proving skills or inquiry skills related to the problems.

## Learning Content and Activities

The course content covers a few results about maximizing the area of figures. It involves knowledge of senior form Mathematics. These learning contents can finally lead to the result that ‘If the perimeter of a polygon is fixed, the area of the polygon is maximum when it is regular.’ With the concept of limit, this result can finally explain why the circle encloses the greatest area among all the closed curves in a plane. The programme provides an approach to explain the isoperimetric problem. Through this programme, a few Mathematical thinking and proving skills are highlighted. The programme is divided into 7 units corresponding to 7 lessons of about 60 to 75 minutes, plus an extension unit which is not covered in lesson time.

Unit	Preliminary Knowledge		
A & B	<ul style="list-style-type: none"> <li>- Trigonometric Ratios of Triangles (S2 Level)</li> <li>- Trigonometric Identities (S2/S3 Level)</li> <li>- General trigonometric functions (S4 Level)</li> <li>- Area Formula : <math>\frac{1}{2} ab \sin \theta</math> (S4 Level)</li> <li>- Heron’s Formula (S4 Level)</li> <li>- Completing Square (S4 Level)</li> </ul> <p>In the lessons, teacher goes through the above methods or theorems with a few drilling exercise. Lesson Plans and materials are not provided. Teacher can refer to regular curriculum content.</p>		
Unit	Pre-lesson Content	Content during / after Lesson	Skills Highlighted
C	Graph of sine and cosine functions	<p><b>Triangle and Rectangle</b> Under fixed perimeter,</p> <p>(A) if the length of two sides of a triangle is fixed, the area is maximum when it is a right-angled triangle.</p> <p>(B) if the length of one side of a triangle is fixed, the area is maximum when the rest of the two sides have equal lengths.</p> <p>(C) square has the largest area among rectangles</p>	<p>Using Formula</p> <p>Algebraic Method (Completing the Square)</p>
D	Triangle Inequality Quadrilateral Inequality	<p><b>From Triangle to Quadrilateral</b></p> <p>(D1) Given 3 lengths, only one unique triangle can be formed.</p> <p>(D2) Given 4 lengths, more than one can be formed.</p> <p>(E1) For any triangle, there exists a circle the three vertices of the triangle.</p> <p>(E2) For some quadrilaterals, there does not exist a circle passing the four vertices of the quadrilateral.</p>	<p>Generalizing results</p> <p>Disproof by counter-example</p>

Unit	Pre-lesson Content	Content during / after Lesson	Skills Highlighted
E	Angle at centre twice angle at circumference  Opposite angles of cyclic quadrilateral	<b>Property of Circle</b> (F) A quadrilateral is cyclic if opposite angles are supplementary.  (G) A problem related to angle at centre twice angle at circumference.	Separate proof into cases  Proof by Contradiction
F	Angles in the same segment  Problem (B) revisited	<b>Polygon (1)</b> (H) For any concave polygon, a convex polygon can be constructed so that the perimeter is unchanged but the area is greater.  (Assumption) Under fixed perimeter and number of sides, there exists a polygon having the greatest area.  (I) Under fixed perimeter, area of equilateral polygon is larger than that of polygon.	Suggesting a geometric construction  Proof by Contradiction
G	Equilateral cannot imply regular  Bretschneider's Formula	<b>Polygon (2)</b> (J) Given 4 lengths of a quadrilateral, the area is maximum when it is a cyclic quadrilateral.  (K) Final Result: Prove the area of regular polygon is larger than that of equilateral polygon under fixed perimeter.	Using Formula  Proof by using previous results
H (Extension)	<b>Isoperimetric Problem</b> Supplementary materials are provided for self-study. Area formula for a regular polygon, Limit, Isoperimetric Problem and its importance.		

## Discussion

Three lessons (Units 4, 5 and 7) of the programme were observed by the Project GIFT team. It was observed that student participants were keen on learning Mathematics and had strong task commitment. For Unit 4, student participants could acquire the skills of disproving a statement by giving counter-examples. Some of them could give more than one counter-example. For Unit 5, students were puzzled about the idea of 'Proof by Contradiction' as this type of proof seldom appeared in the general Math curriculum. However, students still wrote down the notes and some of them stayed behind to ask the instructors after the lesson. For Unit 7, which is the last lesson, the instructors asked students to recall the knowledge they had learnt in the programme. Some students reflected that they had learnt content knowledge related to trigonometry, properties of circle and area formula. Some students moved on to answer they had learnt the way to disprove a statement by counter-example and a new type of proof called proof by contradiction. All these responses provided evidence that both knowledge and thinking skills were delivered to students effectively through the programme.

In each of the three lessons observed, the instructors took turns to lead the discussions while presenting the learning points and engaging students in discussions. They were well-prepared as they provided suitable hints and helped learners acquire the content knowledge with a variety of questions. They also responded to students' answers and questions properly and brought in further discussion. They insisted on the rigorous nature of Mathematics and helped students to justify their answer with strong reasoning. On top of that, they all adopted a serious attitude towards taking forward the lesson, they also demonstrated genuine interest in learning math and the joy of having a problem solved. As a result, student learners were mobilized and kept on-task. Their performance was highly appreciated by both the Project GIFT team and the teacher-in-charge of the pull-out programme.

Throughout the implementation of the programme, students and instructors could handle the learning tasks very well except the tasks related to proof by contradiction, which is the major focus of Unit 5 and Unit 6. It is advised to involve discussion about the negation of 'If-then statements' in Unit 5 and Unit 6. Also, teachers or instructors can introduce some more proofs by contradiction such as the proofs for 'There are infinitely many primes', ' $\sqrt{2}$  is irrational' and 'Converse of Pythagorean Theorem'.

Overall, the Project School displayed a way to start a student-led pull-out programme in this programme. Teachers set the major focus of the whole programme and designed the learning materials of each lesson. High-ability senior form students with good presentation and leadership skills were chosen as instructors. To train them, they were asked to understand the course content through self-learning. In the first few lessons, teachers demonstrated skills in raising questions and leading whole-class discussions in a pull-out class. In the later lessons, student instructors took the role as instructors. Teachers might only help teach a small section or help the instructors by giving suggestions after the lesson. In the long run, the instructors could become mature and confident enough to hold the class without teacher assistance. The student instructors in the project school reflected that they were delighted to see their own improvements in driving the atmosphere of the lesson, interacting with students, identifying students' learning difficulties and managing time. These reflections provided evidence that both student participants and instructors could benefit through peer-mentoring.

# Lesson Plan

## Unit A, B & H

Lesson plans are not provided. Teacher can refer to regular curriculum content and extension materials.

## Unit C

<b>Topic</b>	Triangle and Rectangle
<b>Prior Knowledge</b>	<ul style="list-style-type: none"><li>- Basic Trigonometry</li><li>- Completing Square</li><li>- Heron's Formula</li></ul>
<b>Learning Objectives</b>	<ul style="list-style-type: none"><li>- Students can develop intuitive idea about maximizing area</li><li>- Students can apply algebraic method in Mathematical inquiry</li><li>- Students can choose suitable formula in Mathematical inquiry</li></ul>
<b>Intended Learning Outcomes</b>	<ul style="list-style-type: none"><li>- Students investigate the problems with algebraic method, including setting up variables according to the question setting, choosing appropriate formula to calculate the area of triangle, distinguishing the constant from variables in an expression, and describing the geometric meaning implied by the algebraic expressions</li><li>- Students are committed to solving the problems, by trying even if they cannot get the answers immediately, and asking teaching for hints</li></ul>
<b>Learning &amp; Teaching Strategies</b>	Guided Discovery Activities, Group Discussion

### Pre-lesson Task

Visit the websites and finish Pre-lesson Worksheet 1:

<https://www.mathsisfun.com/algebra/trig-sin-cos-tan-graphs.html>

<https://www.youtube.com/watch?v=a0LvqflQMx4>

### Procedure

Learning Focus	Activity / Content	Learning & Teaching Strategies
Review on the prior knowledge	Teacher makes a review on the prior knowledge related to the unit with the students.	
Pre-lesson knowledge	Students share their pre-lesson findings with reference to the Pre-lesson Worksheet 1.	Pre-lesson Worksheet 1
Problem-solving	Students work in groups to solve the three problems in the Lesson Worksheets. Teachers can provide hints when necessary. Students then present their solutions.	Lesson Worksheets 1-3
Summary	<ol style="list-style-type: none"><li>1. Teacher summarizes some important inquiry skills, including choosing suitable formula, and the algebraic method of setting variables and constants, completing the square etc.</li><li>2. Teacher introduces the isoperimetric problem – A circle encloses the greatest area of a closed curve under a fixed perimeter.</li></ol>	



## Unit D

<b>Topic</b>	From Triangle to Quadrilateral
<b>Prior Knowledge</b>	Congruent Triangles
<b>Learning Objectives</b>	<ul style="list-style-type: none"> <li>- Students understand that a statement can be disproved by counter-examples</li> <li>- Students appreciate that Mathematics results can be generalized to get new problems and new findings</li> </ul>
<b>Intended Learning Outcomes</b>	<ul style="list-style-type: none"> <li>- Students can give counter-example to disprove statements</li> <li>- Students are committed to solving the problems, by trying even if they cannot get the answers immediately, and following teachers' guidelines to move forward</li> </ul>
<b>Learning &amp; Teaching Strategies</b>	Guided Discovery Activities, Group Discussion

### Pre-lesson Task

Visit the websites and finish Pre-lesson Worksheet 2:

<https://www.basic-mathematics.com/triangle-inequality-theorem-proof.html>

<https://www.quora.com/How-do-I-prove-that-sum-of-any-three-sides-in-a-quadrilateral-is-greater-than-the-fourth-side>

## Procedure

Learning Focus (Time)	Activity / Content	Learning & Teaching Strategies
<b>Pre-lesson knowledge</b>	Students present the proofs of Triangle Inequality and Quadrilateral Inequality	Pre-lesson Worksheet 2
<b>Problem-solving</b>	Students work in groups to solve problems in the Lesson Worksheets. Teachers can provide hints when necessary. Students then present their solutions.	Lesson Worksheets 4 - 5
<b>Summary and extension</b>	<ol style="list-style-type: none"> <li>1. Teacher summarizes some important skills, including giving counter-example to disprove a statement, and generalizing results may lead to new problems and eventually new findings</li> <li>2. Teacher can introduce the four special centres of triangles and the related geometric properties. Teachers can also ask students to pose question about quadrilateral based on some property of triangles.</li> </ol>	

### Extended Learning Activity

Prove that the three angle bisectors of triangle are concurrent. Students can visit the website for the solution and more information.

<https://www.algebra.com/algebra/homework/Triangles/Angle-bisectors-of-a-triangle-are-concurrent.lesson>

## Unit E

<b>Topic</b>	Property of Circle
<b>Prior Knowledge</b>	Basic Geometry
<b>Learning Objectives</b>	<ul style="list-style-type: none"> <li>- Students can understand the idea of Proof by Contradiction</li> <li>- Students can separate the cases appropriately when proving a statement</li> </ul>
<b>Intended Learning Outcomes</b>	<ul style="list-style-type: none"> <li>- Students can understand the idea of Proof by Contradiction, by writing down correctly the negation of an 'If-Then' statement, and constructing suitable figures and adding suitable lines related to the negation</li> <li>- Students are committed to solving the problems, by trying to sketch figures to get ideas about the problems, trying to construct different quadrilaterals and look for pattern, and asking teaching for hints</li> </ul>
<b>Learning &amp; Teaching Strategies</b>	Guided Discovery Activities, Group Discussion

### Pre-lesson Tasks

Visit the websites and finish Pre-lesson Worksheet 3:

<https://revisionmaths.com/gcse-maths-revision/shape-and-space/cyclic-quadrilaterals>

## Procedure

Learning Focus	Activity / Content	Learning & Teaching Strategies
<b>Pre-lesson knowledge</b>	<ol style="list-style-type: none"> <li>1. Students share their pre-lesson findings with reference to the Pre-lesson Worksheet 3.</li> <li>2. Teacher summarizes that sometimes we need to separate the cases when proving a statement</li> </ol>	Pre-lesson Worksheet 3
<b>Problem-solving</b>	Students work in groups to solve the problems. Teachers can provide hints when necessary (Outlining a proof by contradiction may be new and difficult to students. Teacher may provide more help). Students then present their solutions, and teacher restates the logic of Proof by Contradiction.	Lesson Worksheets 6 - 7
<b>Summary and extension</b>	<ol style="list-style-type: none"> <li>1. Teacher summarizes some important inquiry skills, including separating proof into cases, and Proof by Contradiction.</li> <li>2. Teacher introduces some more proofs by contradiction: <ul style="list-style-type: none"> <li>- There are infinitely many primes</li> <li>- <math>\sqrt{2}</math> is irrational</li> <li>- Converse of Pythagorean Theorem</li> </ul> </li> <li>3. Teacher can ask students to try outlining a proof by contradiction to write down the negation of the above statements.</li> </ol>	

### Extended Learning Activity

The following proof by contradiction can be introduced to students.

- A Proof for the Converse of the Pythagorean Theorem<sup>1</sup>
- Making sense of irrational numbers - Ganesh Pai – A proof by contradiction is included in the video<sup>2</sup>
- Proof: There are Infinitely Many Primes (There is no Largest Prime)<sup>3</sup>

<sup>1</sup> <https://jwilson.coe.uga.edu/emat6680/brown/6690/ConPythagThm.htm>

<sup>2</sup> [https://www.youtube.com/watch?v=sbGjr\\_awePE](https://www.youtube.com/watch?v=sbGjr_awePE)

<sup>3</sup> <https://www.youtube.com/watch?v=ZYkZws-23R8>

## Unit F

<b>Topic</b>	Polygon (1)
<b>Prior Knowledge</b>	<ul style="list-style-type: none"> <li>- Basic Geometry</li> <li>- Proof by Contradiction</li> </ul>
<b>Learning Objectives</b>	<ul style="list-style-type: none"> <li>- Students can understand the idea of 'Proof by Giving Geometric Construction'</li> <li>- Students can apply Proof by Contradiction</li> </ul>
<b>Intended Learning Outcomes</b>	<ul style="list-style-type: none"> <li>- Students can understand the idea of "Proof by Giving Geometric Construction", by suggesting (one or more) ways to convert a concave polygon to convex polygon with the same perimeter, and explaining the construction steps using straight edge and compasses</li> <li>- Students can apply the proving skills flexibly, using Proof by Contradiction and writing down the negation of the statement in the problems</li> <li>- Students are committed to solving the problems, by trying even if they cannot get the answers immediately, and asking teaching for hints</li> </ul>
<b>Learning &amp; Teaching Strategies</b>	Guided Discovery Activities, Group Discussion

### Pre-lesson Task

Finish Pre-lesson Worksheet 4.

## Procedure

<b>Learning Focus (Time)</b>	<b>Activity / Content</b>	<b>Learning &amp; Teaching Strategies</b>
<b>Pre-lesson knowledge</b>	<ol style="list-style-type: none"> <li>1. Students share their pre-lesson findings with reference to the Pre-lesson Worksheet 4.</li> <li>2. Teacher summarizes that sometimes we need to separate the cases when proving a statement.</li> </ol>	Pre-lesson Worksheet 4
<b>Problem-solving</b>	Students work in groups to solve the problems in the Lesson Worksheets. Teachers can provide hints when necessary. Students then present their solutions, and teacher restates the logic of Proof by Contradiction and "Proof by Giving Geometric Construction".	Lesson Worksheets 8 - 9
<b>Summary and extension</b>	<ol style="list-style-type: none"> <li>1. Teacher summarizes some important inquiry skills, including Proof by Contradiction and "Proof by Giving Geometric Construction".</li> <li>2. Teacher introduces some more basic construction skills using straight edge and compasses.</li> </ol>	

### Extended Learning Activity

Refer to Problem (H) on Lesson Worksheet 8, give the detailed steps of the geometric constructions using straight edge and compasses.

## Unit G

<b>Topic</b>	Polygon (2)
<b>Prior Knowledge</b>	<ul style="list-style-type: none"> <li>- Basic Geometry</li> <li>- Proof by Contradiction</li> </ul>
<b>Learning Objectives</b>	<ul style="list-style-type: none"> <li>- Students can apply the proving skills learnt before</li> <li>- Students gain interest in the Isoperimetric Problem</li> </ul>
<b>Intended Learning Outcomes</b>	<ul style="list-style-type: none"> <li>- Students can apply the proving skills flexibly, choosing a correct proving method to solve the problems, making use of formula learnt or related prior knowledge, and writing down the negation of the statement when writing proof by contradiction</li> <li>- Students are committed to solving the problems, by trying to sketch figures to get ideas about the problems and asking teaching for hints</li> </ul>
<b>Learning &amp; Teaching Strategies</b>	Guided Discovery Activities, Group Discussion

### Pre-lesson Task

Visit the websites and finish Pre-lesson Worksheet 5:

[https://en.wikipedia.org/wiki/Bretschneider%27s\\_formula](https://en.wikipedia.org/wiki/Bretschneider%27s_formula)

## Procedure

<b>Learning Focus (Time)</b>	<b>Activity / Content</b>	<b>Learning &amp; Teaching Strategies</b>
<b>Pre-lesson knowledge</b>	<ol style="list-style-type: none"> <li>1. Students share their pre-lesson findings with reference to the Pre-lesson Worksheet 5.</li> <li>2. Teacher explains some difficult parts in the proof of Bretschneider's Formula.</li> </ol>	Pre-lesson Worksheet 5
<b>Problem-solving</b>	Students work in groups to solve the problems. Teachers can provide hints when necessary. Students then present their solutions.	Lesson Worksheets 10 - 11
<b>Summary</b>	<ol style="list-style-type: none"> <li>1. Teacher summarizes the previous results and the relation to Problem (K) on the worksheet.</li> <li>2. Teacher introduces the Isoperimetric Problem:                     <ul style="list-style-type: none"> <li>- For a closed curve with fixed length, what kind of curve encloses the greatest area?</li> <li>- Students may already know that the answer is Circle. Teacher can tell about the importance of the problem. For example, some walled cities in the history were in circular.</li> </ul> </li> </ol>	

### Extended Learning Activity

Teacher can suggest students to move from Problem (K) to the investigation of Isoperimetric Problem using Unit H - Extension Materials.

# Unit C

## Pre-lesson Worksheet 1

### Trigonometric function

1.  $y = \sin x$  ,  $0^\circ \leq x \leq 360^\circ$

- a. What is the range of  $\sin x$  ?

\_\_\_\_\_

- b. What is the maximum value of  $\sin x$  and the corresponding value of  $x$  ?

\_\_\_\_\_

- c. What is the minimum value of  $\sin x$  and the corresponding value of  $x$  ?

\_\_\_\_\_

2.  $y = \cos x$  ,  $0^\circ \leq x \leq 360^\circ$

- a. What is the range of  $\cos x$  ?

\_\_\_\_\_

- b. What is the maximum value of  $\cos x$  and the corresponding value of  $x$  ?

\_\_\_\_\_

- c. What is the minimum value of  $\cos x$  and the corresponding value of  $x$  ?

\_\_\_\_\_

3. Are there any characteristics in these two graphs?

\_\_\_\_\_

4. Compound angle formulae

- a. Write down the formulae of  $\sin(A+B)$  and  $\cos(A+B)$ .

\_\_\_\_\_

\_\_\_\_\_

- b. Using the above result, find the formulae of  $\sin 2A$  and  $\cos 2A$ .

\_\_\_\_\_

\_\_\_\_\_



Scan the QR code to understand more about sine and cosine functions.



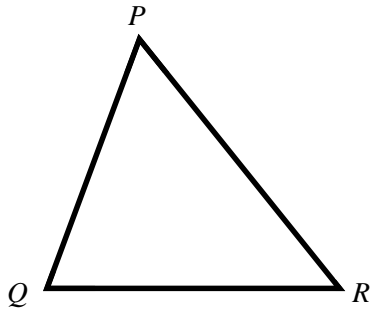
Scan the QR code to understand the compound angle formula.

## Unit C

### Lesson Worksheets 1 - 3

#### Lesson Worksheet 1

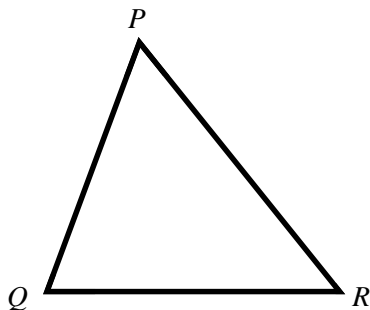
##### Problem (A)



If the lengths of  $QR$  and  $PQ$  are fixed, when does the triangle attain the greatest area? Explain your answer.

#### Lesson Worksheet 2

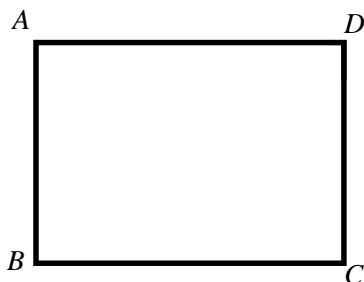
##### Problem (B)



It is given that the perimeter of a triangle  $PQR$  is 24 cm. If the length of  $QR$  is  $a$  cm, where  $a$  is constant and  $P$  is a moving point, when does the triangle attain the greatest area? Explain your answer.

#### Lesson Worksheet 3

##### Problem (C)



It is given that the perimeter of rectangle  $ABCD$  is 24 cm. When does the rectangle attain the greatest area? Explain your answer.

# Unit C

## Suggested Answers and Guidelines

### Suggested Answers and Guidelines for Unit C

#### Pre-lesson Worksheet 1

1.  $y = \sin x$  ,  $0^\circ \leq x \leq 360^\circ$

a. What is the range of  $\sin x$  ?

$$-1 \leq \sin x \leq 1$$

b. What is the maximum value of  $\sin x$  and the corresponding value of  $x$  ?

$$\sin x = 1, x = 90^\circ$$

c. What is the minimum value of  $\sin x$  and the corresponding value of  $x$  ?

$$\sin x = -1, x = 270^\circ$$

2.  $y = \cos x$  ,  $0^\circ \leq x \leq 360^\circ$

a. What is the range of  $\cos x$  ?

$$-1 \leq \cos x \leq 1$$

b. What is the maximum value of  $\cos x$  and the corresponding value of  $x$  ?

$$\cos x = 1, x = 0^\circ \text{ or } 360^\circ$$

c. What is the minimum value of  $\cos x$  and the corresponding value of  $x$  ?

$$\cos x = -1, x = 180^\circ$$

3. Are there any characteristics in these two graphs?

(Any reasonable answers)

4. Compound angle formulae

a. Write down the formulae of  $\sin(A+B)$  and  $\cos(A+B)$ .

$$\sin(A+B) = \sin A \cos B + \cos A \sin B$$

$$\cos(A+B) = \cos A \cos B - \sin A \sin B$$

b. Using the above result, find the formulae of  $\sin 2A$  and  $\cos 2A$ .

$$\sin 2A = 2 \sin A \cos B$$

$$\cos 2A = \cos^2 A - \sin^2 B$$

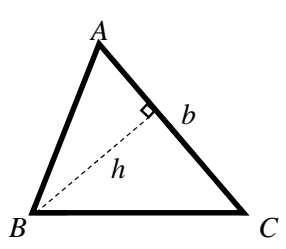
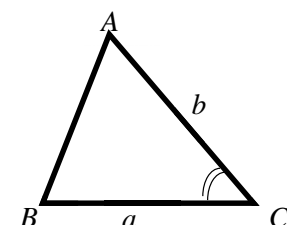
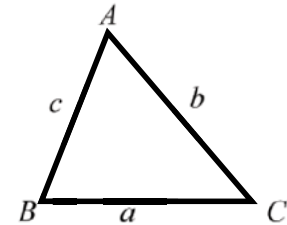


# Unit C

## Suggested Answers and Guidelines

### Lesson Worksheet 1

Hints/Guiding questions (Provide to students when necessary)

Area of triangle can be obtained by		
<p>(1) <math>A = \frac{bh}{2}</math></p> 	<p>(2) <math>A = \frac{1}{2}ab \sin C</math></p> 	<p>(3) <math>A = \sqrt{s(s-a)(s-b)(s-c)}</math></p> <p>where <math>s = \frac{a+b+c}{2}</math></p> 

Which formulae is suitable for this case? Why?

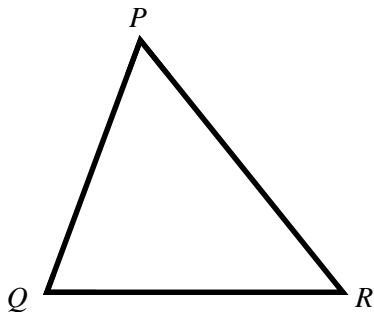
$$(2) \quad A = \frac{1}{2}ab \sin C .$$

We can set the two fixed lengths as  $a$  and  $b$ , leaving the angle  $C$  to be the only variable.

What is the maximum value of  $\sin x$  ?

Maximum value = 1

### Solution to Problem (A)



If the lengths of  $QR$  and  $PQ$  are fixed numbers, when does the triangle attain the greatest area? Explain your answer.

$$0^\circ < \angle PQR < 180^\circ$$

$$0 < \sin \angle PQR \leq 1$$

$$\sin \angle PQR = 1 \text{ when } \angle PQR = 90^\circ$$

$$\text{Area} = \frac{1}{2}(PQ)(QR)\sin \angle PQR$$

Area is maximum when  $\sin \angle PQR = 1$  .

Area is maximum when  $\angle PQR = 90^\circ$  .

# Unit C

## Suggested Answers and Guidelines

### Lesson Worksheet 2

Hints/Guiding questions (Provide to students when necessary)

Hints (1)

Use Heron's Formula to find the area of triangle.

Hints (2)

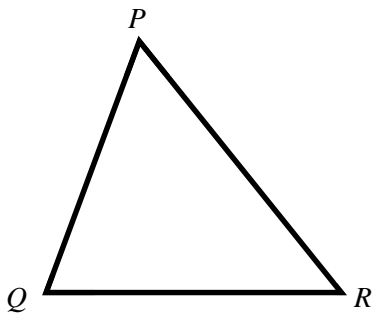
(1) Replace  $12 - a$  by  $t$ .

(2) After replacement, which one is variable?

Hints (3)

Use completing the square.

### Solution to Problem (B)



It is given that the perimeter of a triangle  $PQR$  is 24 cm. If the length of  $QR$  is  $a$  cm, where  $a$  is constant and  $P$  is a moving point, when does the triangle attain the greatest area? Explain your answer.

Assume  $PQ + PR = 2t$ , where  $t$  is a constant

$PQ = t + x$  and  $PR = t - x$ , where  $x$  is a variable

$$\begin{aligned}\text{Area} &= \sqrt{12(12-a)[12-(t-x)][12-(t+x)]} \\ &= \sqrt{12(12-a)[(12-t)+x][(12-t)-x]} \\ &= \sqrt{12(12-a)[(12-t)^2 - x^2]}\end{aligned}$$

$\therefore 12, (12-a)$  and  $t$  are constants

$\therefore (12-t)^2 - x^2$  is maximum when  $x = 0$

When  $x = 0$ ,  $PQ = PR$

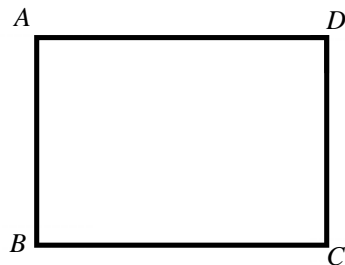
When  $PQR$  is an isosceles triangle with  $PQ = PR$ , it attains the greatest area.

# Unit C

## Suggested Answers and Guidelines

### Lesson Worksheet 3

#### Solution to Problem (C)



It is given that the perimeter of rectangle  $ABCD$  is 24 cm. When does the rectangle attain the greatest area?

Let  $AB = x$ , where  $x$  is a variable

$$\begin{aligned} \text{Area} &= x\left(\frac{24}{2} - x\right) \\ &= x(12 - x) \\ &= -x^2 + 12x \\ &= -(x - 6)^2 + 36 \end{aligned}$$

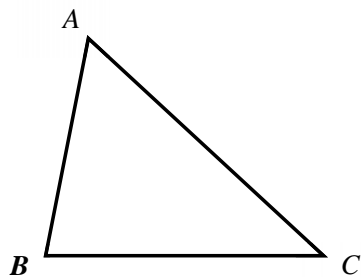
Area is maximum when  $x = 6$ , which means when it is a square.

# Unit D

## Pre-lesson Worksheet 2

### Triangle Inequality

#### 1. Triangle inequality



Write down the triangle inequality.

---

---

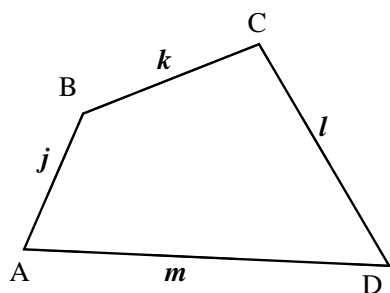
---

---



Triangle Inequality

#### 2. Quadrilateral inequality



(A) Guess the quadrilateral inequality.



Quadrilateral Inequality

(B) Verify it by using the triangle inequality.  
(If you can prove by yourselves, Well Done!  
If you have no idea, scan the QR code for help.)

## Unit D

### Lesson Worksheets 4 - 5

#### Lesson Worksheet 4

##### **Problem (D1)**

If you have three given lengths (satisfying the Triangle Inequality), how many different triangles can you make from these lengths?

##### **Problem (D2)**

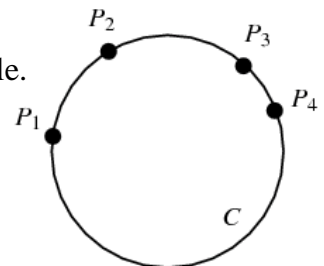
If you have four given lengths (satisfying the Quadrilateral Inequality), is there only ONE quadrilateral that can be formed? Explain your answer.

#### Lesson Worksheet 5

##### **Definition: Concyclic points**

A set of points are said to be concyclic if they lie on a common circle.

In the figure,  $P_1$ ,  $P_2$ ,  $P_3$  and  $P_4$  are concyclic.



##### **Problem (E1)**

Prove any three non-collinear points always concyclic.

##### **Problem (E2)**

Is it true that any four points (not three of them are collinear) are always concyclic?

# Unit D

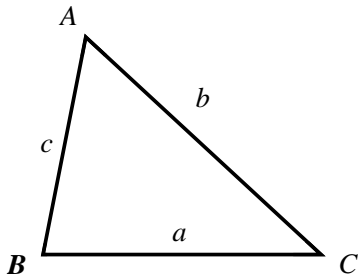
## Suggested Answers and Guidelines

### Suggested Answers and Guidelines for Unit D

#### Pre-lesson Worksheet 2

#### Triangle Inequality

##### Proof of Triangle inequality

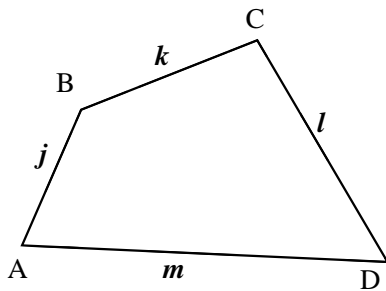


Write down the triangle inequality.

$$\begin{aligned} a + b &> c \\ b + c &> a \\ a + c &> b \end{aligned}$$

Draw triangle ABC and the line perpendicular to BC passing through vertex A.  
 Now prove that  $BA + AC > BC$   
 BE is the shortest distance from vertex B to AE, This means  $BA > BE$   
 CE is the shortest distance from C to AE. This means  $AC > CE$   
 $BA > BE$  and  $AC > CE$   
 Add the left side and add the right of the inequalities. This gives:  
 $BA + AC > BE + CE = BC$

##### Proof of Quadrilateral inequality



(A) Guess the quadrilateral inequality.

$$\begin{aligned} j + k + m &> l \\ m + l + k &> j \\ l + k + j &> m \end{aligned}$$

(B) Verify it by using the triangle inequality.

Join AC as shown.  
 By Triangle Inequality  
 $j + k > n$  and  $n + m > l$   
 $j + k + m > n + m$   
 $j + k + m > l$   
 Similarly  
 $m + l > n$  and  $n + k > j$   
 $m + l + k > n + k$   
 $m + l + k > j$

# Unit D

## Suggested Answers and Guidelines

### Lesson Worksheet 4

#### Problem (D1)

If you have three given lengths (satisfying the Triangle Inequality), how many different triangles can you make from these lengths?

#### Solution to Problem (D1)

A unique triangle can be formed due to the condition for congruent triangles (S.S.S.). Or we can use cosine formula to find each angle.

#### Problem (D2)

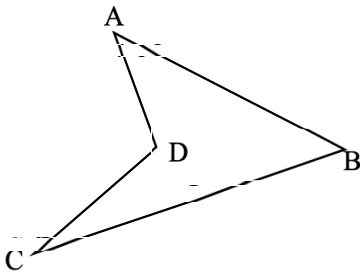
If you have four given lengths (satisfying the Quadrilateral Inequality), is there only ONE quadrilateral that can be formed? Explain your answer.

**Guideline: If yes, give reasons logically. If not, just give one Counter-example.**

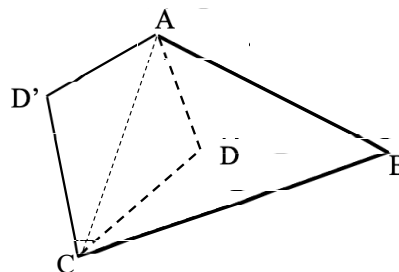
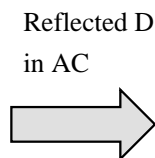
#### Solution to Problem (D2)

Some counter-examples can be suggested to students:

(a) Concave



Convex, keeping all 4 lengths equal



(b) Rhombus and Square

(c) Parallelogram and Rectangle

# Unit D

## Suggested Answers and Guidelines

### Lesson Worksheet 5

#### Problem (E1)

Prove any three non-collinear points always concyclic.

#### Guideline 1:

Let  $A$ ,  $B$  and  $C$  be the three non-collinear points.

To prove the statement, we need to find out a way to construct a circle passing  $A$ ,  $B$  and  $C$

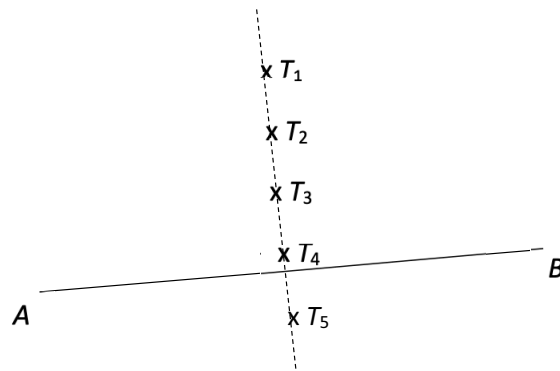
To construct the circle, we need to locate the centre.

#### Guideline 2:

Suppose  $X$  is the centre of the circle we want,  $X$  should satisfy the property  $XA = XB = XC$ .

We can begin with the following questions:

- (a)  $A$  and  $B$  are fixed point, is it possible to find a point  $T$  such that  $AT = BT$ ?
- (b) Other than point  $T$ , any other point(s) also equidistant from  $A$  and  $B$ ?
- (c) Joining all the points to become a straight line, what's the relationship between the straight line and  $AB$ ?



The above questions guide students to conclude that  $X$  lies on the perpendicular bisector of  $AB$ .

#### Guideline 3:

There are perpendicular bisectors of  $AB$ ,  $BC$  and  $AC$  respectively, do they intersect at a point?

Teacher may ask them to roughly draw (or construct by compass and straight edge if they have learnt before) the perpendicular bisectors to get intuitive ideas before jumping to the proof that the perpendicular bisectors always concurrent.



## Unit D

### Suggested Answers and Guidelines

#### Solution to Problem (E1)

##### [Proof that three perpendicular bisectors are concurrent]

Let  $L_2$  and  $L_3$  be the perpendicular bisectors of  $BC$  and  $AB$  respectively

Denote the point of intersection of  $L_2$  and  $L_3$  as  $X$

$$\triangle XBE \cong \triangle XCE \text{ (S.A.S)}$$

$$\triangle XBF \cong \triangle XAF \text{ (S.A.S)}$$

$$\therefore XA = XB = XC$$

Let  $Z$  be the mid-point of  $AC$

$$\triangle XAZ \cong \triangle XCZ \text{ (S.S.S)}$$

$$\angle AZX = \angle CZX = 90^\circ$$

$L_1$  is the perpendicular bisector of  $AC$ .

Therefore,

$\triangle ABC$  lies on the circle with centre  $X$  and radius  $AX$

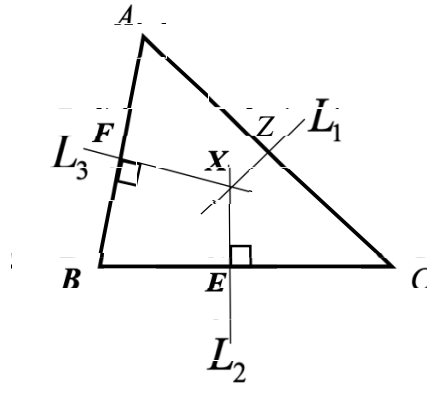
GeoGebra Reference: <https://www.geogebra.org/m/ebpxRqk8>

#### Problem (E2)

Is it true that any four points (not three of them are collinear) are always concyclic?

#### Solution to Problem (E2)

A counter-example can be constructed by first constructing a circle passing through three points, and then choose a point outside / inside the circle to be the 4<sup>th</sup> point.



# Unit E

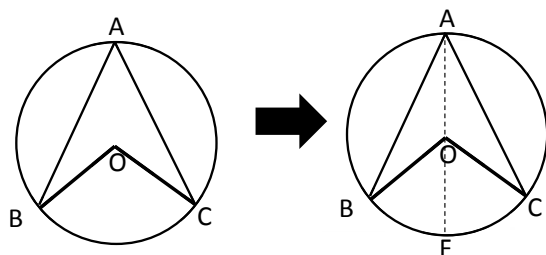
## Pre-lesson Worksheet 3

### Property of Circle

#### (1) Angle at centre twice angle at circumference

Given: O is centre of the circle and A, B and C lie on the circle.

#### Type 1

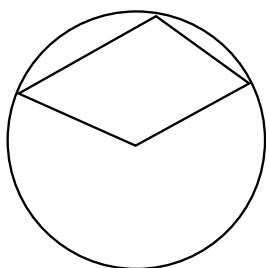


Prove  $\angle BOC = 2\angle BAC$

Proof:

#### Type 2

Prove  $\text{reflex}\angle AOC = 2\angle ABC$ .

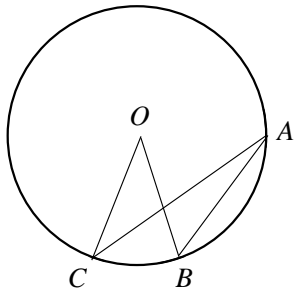


# Unit E

## Pre-lesson Worksheet 3

Type 3

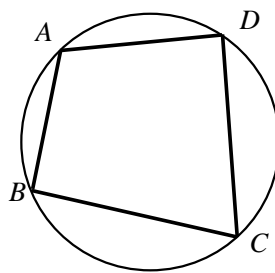
Prove  $\angle BOC = 2\angle BAC$ .



### (2) Cyclic Quadrilateral

(a) What is Cyclic Quadrilateral?

(b) If  $ABCD$  is a cyclic quadrilateral, what result we can obtain?



(c) Prove the result in (b) by using “Angle at centre twice angle at circumference”.

# Unit E

## Lesson Worksheets 6 - 7

### Lesson Worksheet 6

#### Property of Circle

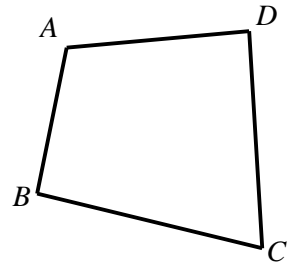
**From the Pre-lesson worksheet, we have the following proposition:**

If  $ABCD$  is a cyclic quadrilateral,  $\angle ABC + \angle ADC = 180^\circ$ .

#### **Problem (F)**

*What is the 'converse' of this proposition? Is it also true?*

*Rewrite it and explain whether it is true or not.*



Converse: Let  $ABCD$  be a quadrilateral.

If  $\angle ABC + \angle ADC = 180^\circ$ , then  $ABCD$  is \_\_\_\_\_.

## Unit E

### Lesson Worksheets 6 - 7

#### Problem (G)

Given a circle with centre  $O$ , and  $A$  and  $B$  are two points on the circle. If  $P$  is a point such that  $\angle AOB = 2\angle APB$ , where  $O$  and  $P$  lying on the same side of chord  $AB$ , prove that  $P$  also lies on the circle.



# Unit E

## Suggested Answers and Guidelines

### Suggested Answers and Guidelines for Unit E

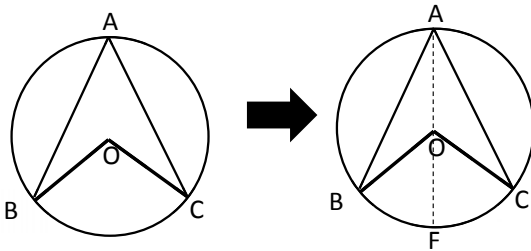
#### Pre-lesson Worksheet 3

#### Property of Circle

##### (1) Angle at centre twice angle at circumference

Given:  $O$  is centre of the circle and  $A, B$  and  $C$  lie on the circle.

Type 1



Prove  $\angle BOC = 2\angle BAC$

Proof:

Extend  $AO$  to the circumference at  $F$

Let  $\angle BAF = x$  and  $\angle CAO = y$

$OA = OB = OC$  (radii)

In  $\triangle OAB$ ,

$\angle BAF = \angle ABO = x$  (base  $\angle$ s, isos  $\triangle$ )

$\angle BOF = 2x$  (ext.  $\angle$  of  $\triangle$ )

In  $\triangle OAC$ ,

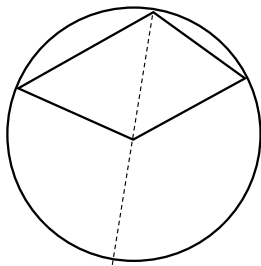
$\angle CAF = \angle ACO = y$  (base  $\angle$ s, isos  $\triangle$ )

$\angle COF = 2y$  (ext.  $\angle$  of  $\triangle$ )

$\angle BOC = 2(x + y)$

$= 2\angle BAC$

##### Type 2



Prove  $\text{reflex}\angle AOC = 2\angle ABC$ .

Extend  $BO$  to the circumference at  $F$

Let  $\angle ABO = x$  and  $\angle CBO = y$

$OA = OB = OC$  (radii)

In  $\triangle OAB$ ,

$\angle BAO = \angle ABO = x$  (base  $\angle$ s, isos  $\triangle$ )

$\angle AOF = 2x$  (ext.  $\angle$  of  $\triangle$ )

In  $\triangle OAC$ ,

$\angle CBO = \angle BCO = y$  (base  $\angle$ s, isos  $\triangle$ )

$\angle COF = 2y$  (ext.  $\angle$  of  $\triangle$ )

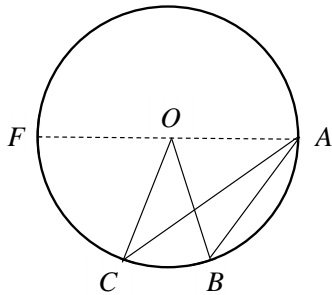
$\text{reflex}\angle AOC = 2(x + y)$

$= 2\angle ABC$

# Unit E

## Suggested Answers and Guidelines

### Type 3



Prove  $\angle BOC = 2\angle BAC$ .

Extend  $AO$  to the circumference at  $F$

Let  $\angle ABO = x$  and  $\angle OCA = y$

$OA = OB = OC$  (radii)

In  $\triangle OAB$ ,

$\angle BAO = \angle ABO = x$  (base  $\angle$ s, isos  $\triangle$ )

$\angle BOF = 2x$  (ext.  $\angle$  of  $\triangle$ )

In  $\triangle OAC$ ,

$\angle OCA = \angle OAC = y$  (base  $\angle$ s, isos  $\triangle$ )

$\angle COF = 2y$  (ext.  $\angle$  of  $\triangle$ )

$\angle BOC = \angle BOF - \angle COF = 2(x - y)$   
 $= 2\angle BAC$

### (2) Cyclic Quadrilateral

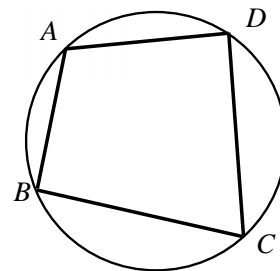
(a) What is Cyclic Quadrilateral?

A cyclic quadrilateral is a quadrilateral drawn inside a circle so that its vertices lie on the circumference of the circle.

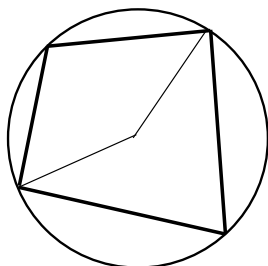
(b) If  $ABCD$  is a cyclic quadrilateral, what result can we obtain?

$$\angle A + \angle C = 180^\circ$$

$$\angle B + \angle D = 180^\circ \text{ (opp. } \angle \text{s, cyclic quad.)}$$



(c) Prove the result in (b) by using “Angle at centre twice angle at circumference”.



Prove:  $\angle A + \angle C = 180^\circ$ .

$\text{reflex} \angle BOD = 2\angle A$  ( $\angle$  at centre twice  $\angle$  at circumference)

$\angle BOD = 2\angle C$  ( $\angle$  at centre twice  $\angle$  at circumference)

$\text{reflex} \angle BOD + \angle BOD = 360^\circ$  ( $\angle$ s at a point)

$$2\angle A + 2\angle C = 360^\circ$$

$$\angle A + \angle C = 180^\circ$$

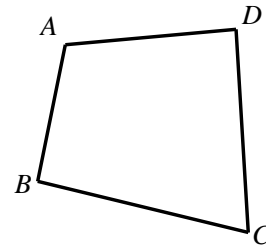
# Unit E

## Suggested Answers and Guidelines

### Lesson Worksheet 6

#### Problem (F)

If  $\angle ABC + \angle ADC = 180^\circ$ , then  $ABCD$  is a cyclic quadrilateral.



#### Hints/Guiding questions (Provide to students when necessary):

(1) Is Converse of a true statement always true?

No.

(2) By your observation or do some trial construction, do you think the converse in Problem (F) is true?

Expect the students to answer 'Yes'.

(3) Can we draw a circle passing through  $A$ ,  $B$  and  $C$ ?

From previous lesson, any three non-collinear points are always concyclic.

There is a unique circle passing through  $A$ ,  $B$  and  $C$

(4) After drawing a circle passing through  $A$ ,  $B$  and  $C$ . what happen to  $D$  if  $ABCD$  is a cyclic quadrilateral?

What happen to  $D$  if  $ABCD$  is not a cyclic quadrilateral?

If  $ABCD$  is a cyclic quadrilateral,  $D$  lies on the same circle.

If  $ABCD$  is not a cyclic quadrilateral,  $D$  lies either inside or outside the same circle.

(5) Rewrite the negation (The result when the statement is wrong) of the statement.

'If  $\angle ABC + \angle ADC = 180^\circ$ , then  $ABCD$  is a cyclic quadrilateral.'

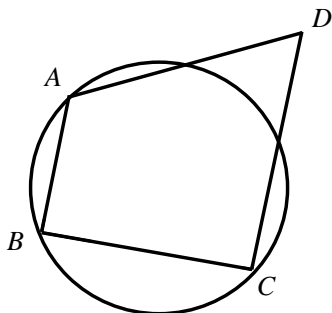
" $\angle ABC + \angle ADC = 180^\circ$  but  $ABCD$  is not a cyclic quadrilateral"

(6) Now we assume the result to be wrong (i.e.  $\angle ABC + \angle ADC = 180^\circ$  but  $ABCD$  is not a cyclic quad.).

What do we need to do in order to prove that the original statement is true?

To show that it is impossible to assume it to be wrong. We should see some contradictions.

(7) Suppose  $D$  is outside the circle, draw a figure.



(8) How to make use of the condition  $\angle ABC + \angle ADC = 180^\circ$ ?

How to make use of the circle and the property of circle?



## Unit E

### Suggested Answers and Guidelines

#### Solution to Problem (F)

Target: Prove that 'if  $\angle ABC + \angle ADC = 180^\circ$ , then  $ABCD$  is cyclic quadrilateral.'

Assume that the statement is false,

i.e.  $\angle ABC + \angle ADC = 180^\circ$  but  $ABCD$  is not a cyclic quadrilateral.

Construct the circumcircle of  $ABC$

By assumption,  $D$  lies either inside or outside the circle.

Consider the case  $D$  lies outside the circle.

Then  $AD$  cuts the circle at  $E$

Join  $CE$  as shown,  $ABCE$  is a cyclic quadrilateral by construction.

i.e.  $\angle ABC + \angle AEC = 180^\circ$  (opp.  $\angle$ s, cyclic quad.)

From the given condition,  $\angle ABC + \angle ADC = 180^\circ$

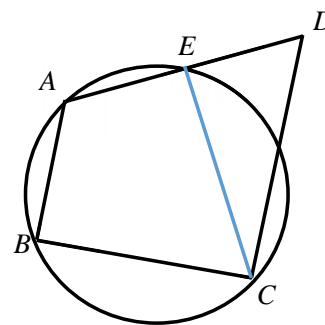
Compare the two equations, we have  $\angle AEC = \angle ADC$

Hence,  $EC \parallel DC$  (corr.  $\angle$ s equal),

which contradicts to the fact that  $EC$  and  $DC$  intersect at  $C$ .

So, the assumption cannot happen.

Therefore, if  $\angle ABC + \angle ADC = 180^\circ$ , then  $ABCD$  is cyclic quadrilateral.



# Unit E

## Suggested Answers and Guidelines

### Lesson Worksheet 7

#### Problem (G)

Given a circle with centre  $O$ , and  $A$  and  $B$  are two points on the circle. If  $P$  is a point such that  $\angle AOB = 2\angle APB$ , where  $O$  and  $P$  lying on the same side of chord  $AB$ , prove that  $P$  also lies on the circle.

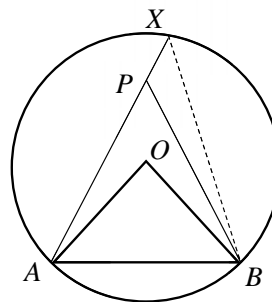
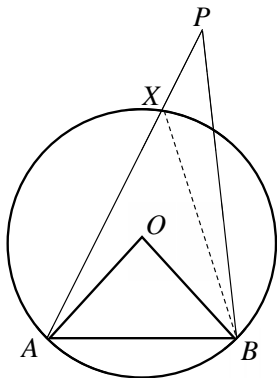
#### Hints/Guiding questions (Provide to students when necessary):

Try to use 'Proof by Contradiction'.

1. Draw a figure with the triangle  $ABP$  which does not satisfy the statement.
2. Let the point join line  $AP$  and the circumference be  $X$ .
3. Make use of property of circle and assumptions to look for contradiction.

#### Solution to Problem (G)

Assume the statement is wrong, i.e.  $P$  is a point such that  $\angle AOB = 2\angle APB$  but  $P$  does not lie on the circle.  $P$  lies either outside or inside the circle as shown in the following figure.



Let  $X$  be the intersection of line  $AP$  and the circumference.

By assumption,  $\angle AOB = 2\angle APB$ .

In the circle,  $\angle AOB = 2\angle AXB$  ( $\angle$  at centre twice  $\angle$  at circumference)

Compare the two equations,  $\angle APB = \angle AXB$

Hence,  $BX \parallel BP$  (corr.  $\angle$ s equal)

This contradicts to the fact that  $BX$  and  $BP$  meet at  $B$ .

Therefore, the statement is proved.

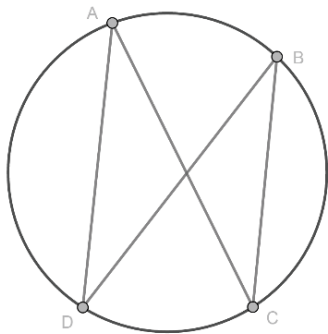
# Unit F

## Pre-lesson Worksheet 4

### Polygon (1)

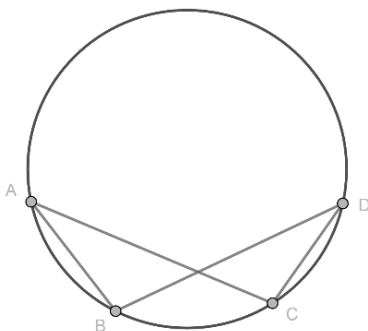
#### (1) Angles in the same segment

##### Type 1



Prove  $\angle DAC = \angle DBC$ .

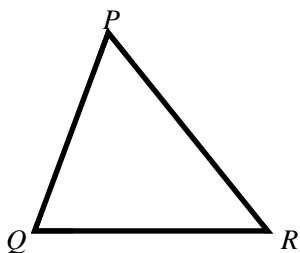
##### Type 2



Prove  $\angle ABD = \angle ACD$ .

The following problem will be useful in the coming lesson. Try it again.

#### **Review: Problem (B)**



It is given that the perimeter of a triangle  $PQR$  is 24 cm .  
If the length of  $QR$  is  $a$  cm, where  $a$  is constant and  $P$  is a moving point, when does the triangle attain the greatest area? Explain your answer.

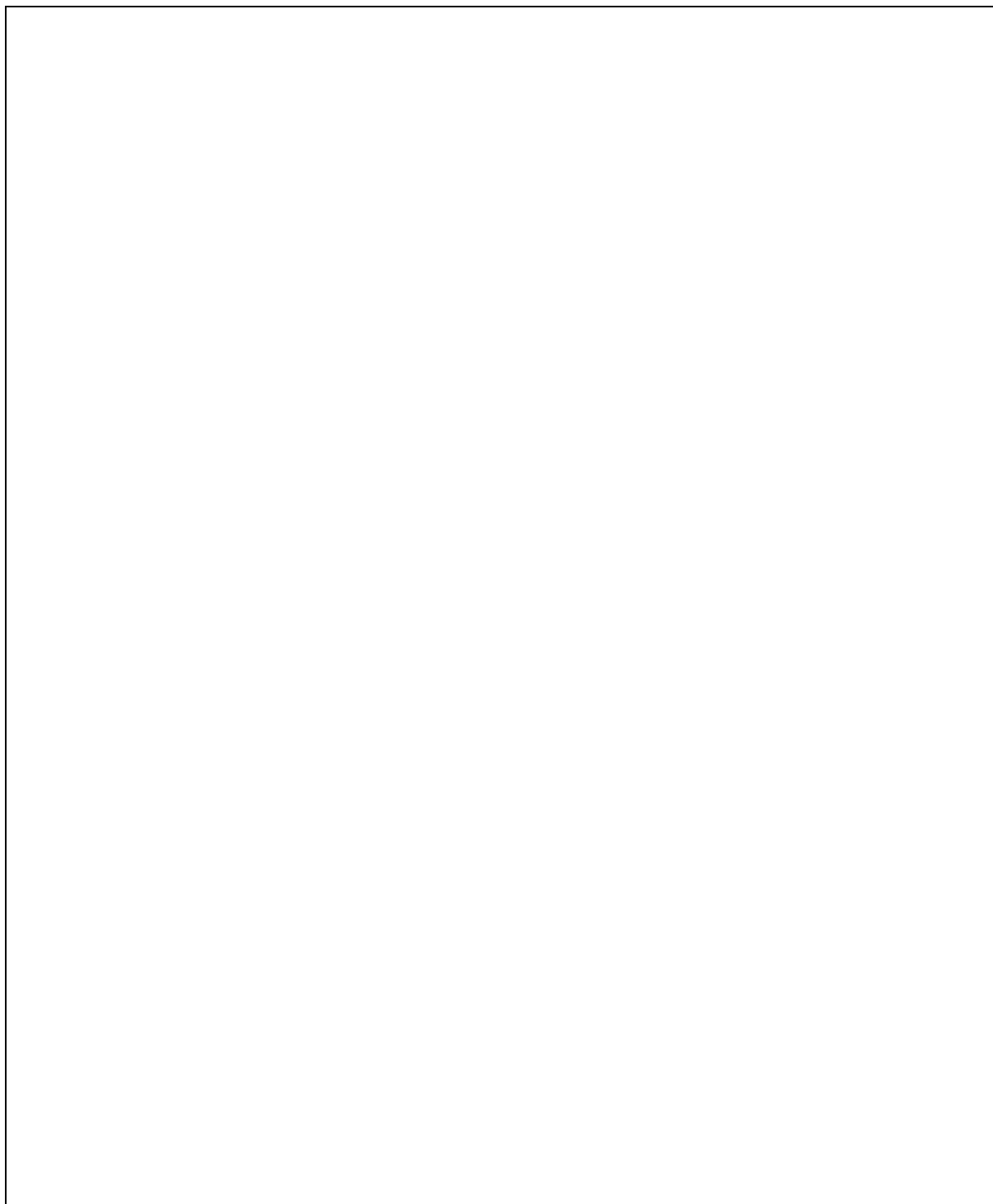
# Unit F

## Lesson Worksheets 8 - 9

### Lesson Worksheet 8

#### **Problem (H)**

Given a concave polygon, describe how to construct a convex polygon with the same perimeter and a larger area than the concave polygon.



## Unit F

### Lesson Worksheets 8 - 9

#### Lesson Worksheet 9

##### **Assumption:**

Under fixed perimeter and number of sides, there is a polygon with the greatest area.

##### **Problem (I):**

Prove that the area of equilateral polygon is larger than that of irregular polygon under fixed perimeter.

**By the assumption, there is a polygon with the greatest area.**

**From the result of Problem (H), the polygon should be convex.**

# Unit F

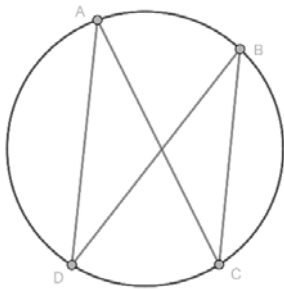
## Suggested Answers and Guidelines

### Suggested Answers and Guidelines for Unit F

#### Pre-lesson Worksheet 4

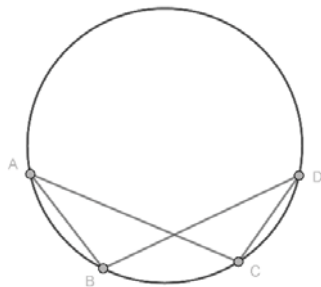
#### (1) Angles in the same segment

##### Type 1



Prove  $\angle DAC = \angle DBC$ .

##### Type 2

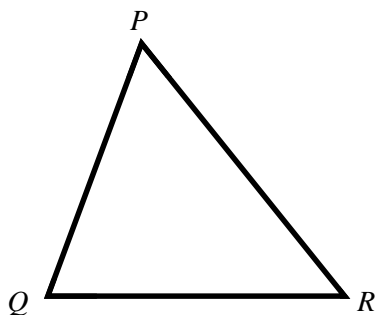


Prove  $\angle ABD = \angle ACD$ .

**Hints:** Add the centre of the circle and apply angles at centre twice angle at circumference.

The following problem will be useful in the coming lesson. Try it again.

#### Review: Problem (B)



It is given that the perimeter of a triangle  $PQR$  is 24 cm. If the length of  $QR$  is  $a$  cm, where  $a$  is constant and  $P$  is a moving point, when does the triangle attain the greatest area? Explain your answer.

**Refer to Unit 3 Problem (B)**

# Unit F

## Suggested Answers and Guidelines

### Lesson Worksheet 8

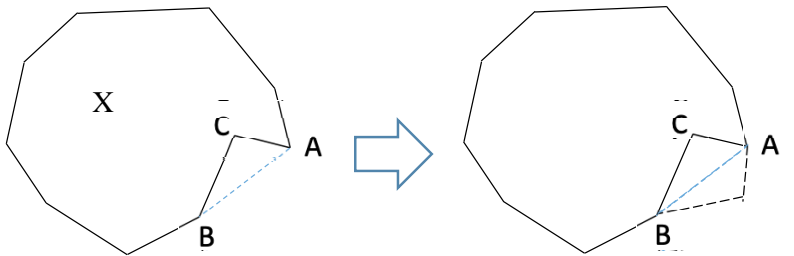
#### Solution to Problem (H)

Given a concave polygon, describe how to construct a convex polygon with the same perimeter and a larger area than the concave polygon.

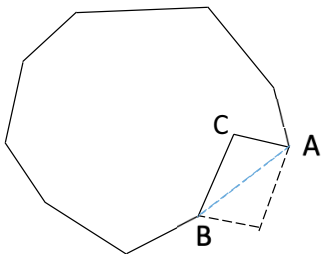
Assume  $X$  is a polygon which is not convex

Reflect  $C$  along  $AB$ . This will keep the length of  $AC$  and  $BC$  unchanged.

Keep doing this for any concave points until the polygon become convex.



Or : Construct a parallelogram with diagonal  $AB$  as shown.



**In Mathematics inquiry, suggesting a way to construct the desired results is an important skill. To be more precise, teacher can ask students to suggest how the above construction works using straight edge and compasses.**

# Unit F

## Suggested Answers and Guidelines

### Lesson Worksheet 9

#### Assumption:

Under fixed perimeter and number of sides, there is a polygon with the greatest area.

**Teacher may explain the importance of this assumption after finishing problem (I).**

**This assumption can be proved by more advanced Mathematics.**

#### Problem (I):

Prove that the area of equilateral polygon is larger than that of irregular polygon under fixed perimeter.

#### Hints/Guiding questions (Provide to students when necessary):

We can use Proof by Contradiction :

If the polygon with the greatest area is NOT equilateral, what happens?

Equilateral means all sides have equal lengths.

Not equilateral means at least one pair of adjacent sides have unequal lengths.

#### Solution to Problem (I)

By the assumption, there is a polygon with the greatest area.  
From the result of Problem (H), the polygon should be convex.

Let  $Y$  be a convex polygon that maximizes the area for given perimeter.

Assume  $Y$  is not equilateral polygon,

i.e. at least 1 pair of adjacent sides unequal ( $AT \neq BT$ )

i.e.  $a \neq b$  but  $a + b$  is fixed

Refer to the Problem (B) in Unit 3,

When  $T$  moves to  $T'$  with  $AT' = BT'$ ,

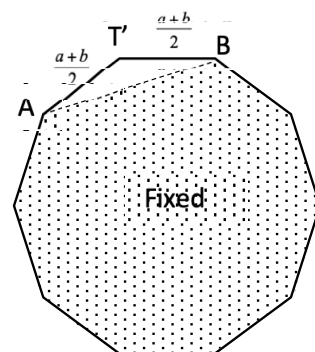
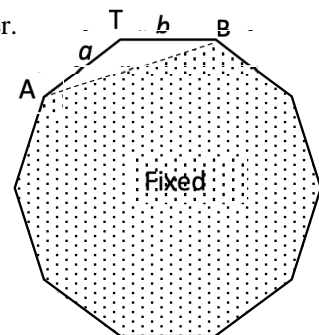
( $\triangle AT'B$  is an isosceles triangle)

the area of  $\triangle AT'B$  is greater than that of  $\triangle ATB$ .

The perimeter of the new polygon is equal to that of polygon  $Y$   
and the area of the new polygon is greater than that of polygon  $Y$ .

This contradicts the assumption that  $Y$  is the polygon that maximizes the area for given perimeter.

**Therefore, the area of equilateral polygon is larger than that of irregular polygon under fixed perimeter.**





# Unit G

## Pre-lesson Worksheet 5

(1) For triangle, 'all three sides have equal lengths' implies 'all three angles are equal'. Is 'all sides have equal lengths' implies 'all angles are equal' for polygon with more than three sides?

(2) Bretschneider's Formula

$a, b, c$  and  $d$  are the fixed lengths of the quadrilateral and  $s$  is the semi-perimeter.

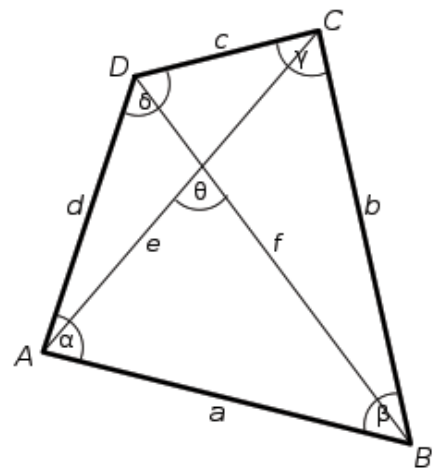
Scan the QR code and write down the Bretschneider's Formula



Proof of Bretschneider's  
Formula

Read the proof of the formula and write down four key formulas used in the proof.

1. Area Formula of Triangle
2. \_\_\_\_\_
3. \_\_\_\_\_
4. \_\_\_\_\_



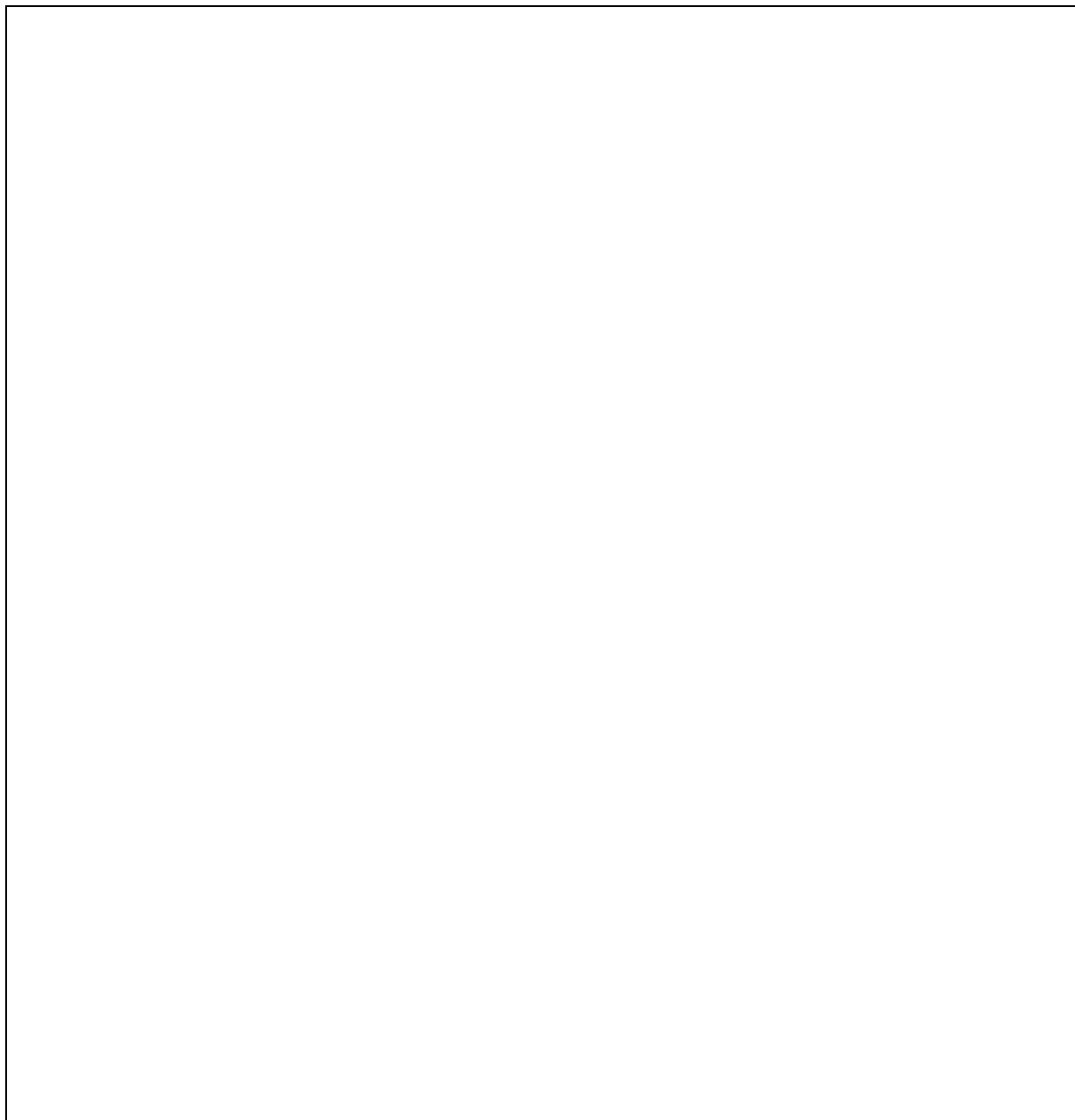
# Unit G

## Lesson Worksheets 10 - 11

### Lesson Worksheet 10

#### **Problem (J)**

Given four fixed lengths (satisfying quadrilateral inequality), prove that the area of the quadrilateral is maximum when it is a cyclic quadrilateral.



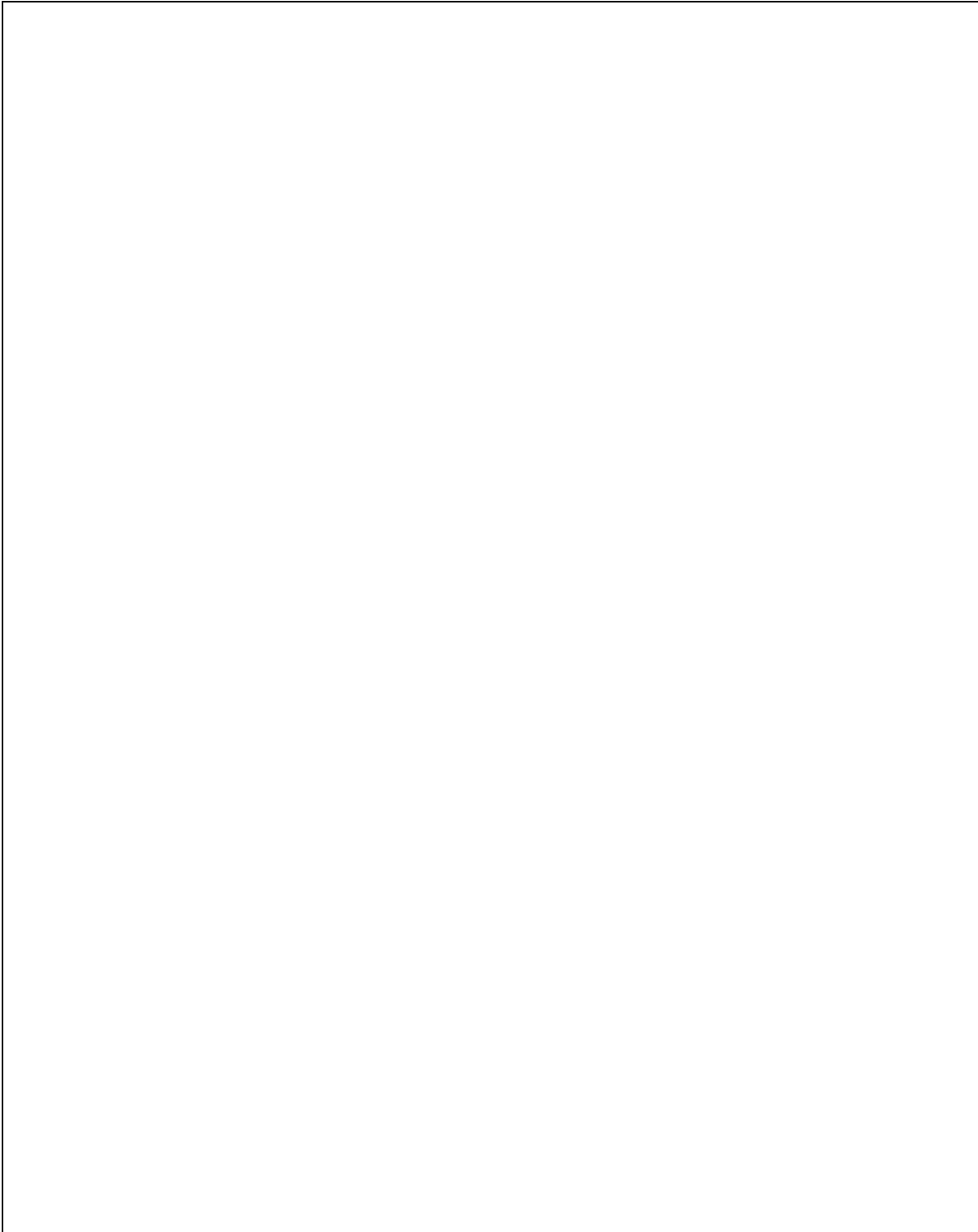
# Unit G

## Lesson Worksheets 10 - 11

### Lesson Worksheet 11

#### Problem (K)

Prove that the area of regular polygon is larger than that of equilateral polygon under fixed perimeter.



# Unit G

## Suggested Answers and Guidelines

### Suggested Answers and Guidelines for Unit G

#### Pre-lesson Worksheet 5

- (1) For triangle, 'all three sides have equal lengths' implies 'all three angles are equal'. Is 'all sides have equal lengths' implies 'all angles are equal' for polygon with more than three sides?

**No. Counter-example: Square and Rhombus.**

- (2) Bretschneider's Formula

$a, b, c$  and  $d$  are the fixed lengths of the quadrilateral

and  $s$  is the semi-perimeter  $\left(s = \frac{a+b+c+d}{2}\right)$



Proof of Bretschneider's Formula

Scan the QR code and write down the Bretschneider's Formula

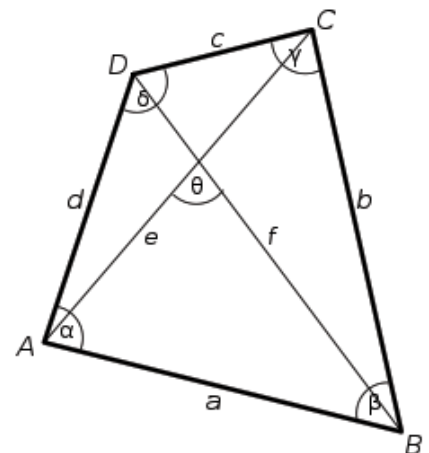
$$\text{Area} = \sqrt{(s-a)(s-b)(s-c)(s-d) - abcd \cos^2\left(\frac{\alpha+\gamma}{2}\right)}$$

The complete proof is given in:

[https://en.wikipedia.org/wiki/Bretschneider%27s\\_formula](https://en.wikipedia.org/wiki/Bretschneider%27s_formula)

Read the proof of the formula and write down four key formulas used in the proof.

1. Area Formula of Triangle
2. Cosine Formula
3. Compound Angle Formula
4. Double-Angle / Half-angle Formula



## Unit G

### Suggested Answers and Guidelines

#### Lesson Worksheet 10

#### Problem (J)

Given four fixed lengths (satisfying quadrilateral inequality), prove that the area of the quadrilateral is maximum when it is a cyclic quadrilateral.

#### Hints/Guiding questions (Provide to students when necessary):

From the formula  $Area = \sqrt{(s-a)(s-b)(s-c)(s-d) - abcd \cos^2\left(\frac{\alpha+\gamma}{2}\right)}$ ,

When will the area be maximum?

#### Solution to Problem (J)

From the formula  $Area = \sqrt{(s-a)(s-b)(s-c)(s-d) - abcd \cos^2\left(\frac{\alpha+\gamma}{2}\right)}$

To have maximum area ,

$$\cos^2\left(\frac{\alpha+\gamma}{2}\right) = 0$$

$$\frac{\alpha+\gamma}{2} = 90^\circ$$

$$\alpha+\gamma = 180^\circ$$

Therefore, the opposite angles of the quadrilateral are supplementary.

By the result of Problem (F) , the quadrilateral is a cyclic quadrilateral.

# Unit G

## Suggested Answers and Guidelines

### Lesson Worksheet 11

Prove that the area of regular polygon is larger than that of equilateral polygon under fixed perimeter.

#### Hints/Guiding questions (Provide to students when necessary):

1. Try to use Proof by Contradiction
2. From the results and assumptions in Unit 6, we already know that the polygon maximizing the area exists and it should be convex and equilateral.
3. Try to sketch a figure following point 2.
4. Suppose the statement of point 2 is not true, what would 'NOT regular' mean?  
It is NOT regular while it is convex and equilateral. This means it is equilateral but not equiangular. This also implies that there is a pair of unequal adjacent angles.
5. Try to locate 4 consecutive points in an equilateral polygon, what can you observe?  
How can you maximize the area of the quadrilateral formed by these 4 points?  
By joining the two diagonals, what angle relations can be observed to be equal?

#### Solution to Problem (K)

Let  $Z$  be an equilateral polygon that maximizes the area for given perimeter  $P$ .  
Assume  $Z$  is not equiangular, i.e. at least 1 pair of adjacent angles unequal  
i.e.  $\angle ATB \neq \angle TBC$

$AT, TB, BC$  and  $AC$  are fixed

Refer to the result of Problem(J),

$ATBC$  is the greatest area when it is a cyclic quadrilateral.

$$\begin{aligned} \angle CTB &= m \\ &= \angle TCB \quad (\text{base } \angle\text{s, isos } \triangle) \\ &= \angle BAT \quad (\angle\text{s in the same segment}) \\ &= \angle ABT \quad (\text{base } \angle\text{s, isos } \triangle) \end{aligned}$$

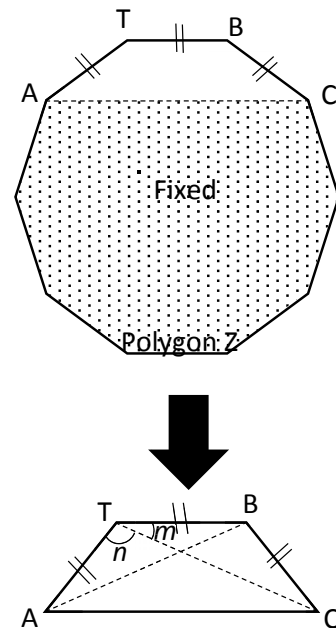
So,  $\angle BTC = \angle ABT = m$

$$\angle ATC = \angle ABC = n \quad (\angle\text{s in the same segment})$$

So,  $\angle ATB = \angle TBC = m + n$

This contradicts to the assumption that  $\angle ATB \neq \angle TBC$

Polygon  $Z$  is a regular polygon that maximize the area under fixed perimeter



# Unit H

## Extension Materials

### Unit H Extension : Isoperimetric Problem

In the programme, we come to the conclusion:

The area of regular polygon is the largest under fixed perimeter.

Following the steps below, we can move on to show that circle encloses the largest area among all closed curve with fixed length. See the following websites to continue your investigations.

- (1) A regular polygon with  $i$  sides has greater area than one with  $j$  sides under a fixed perimeter if and only if  $i > j$ .



Formula of area of regular polygon



Changing area of regular polygon by using GeoGebra

- (2) The second part involves the concepts of radian measures and limits, which will be introduced in M1/M2 syllabus.



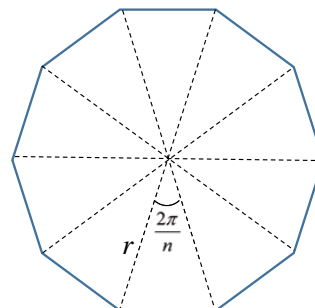
Evaluating  $\lim_{\theta \rightarrow 0} \frac{\sin \theta}{\theta}$

When  $n \rightarrow \infty$ ,

Area of regular polygon

$$\begin{aligned} &= \lim_{n \rightarrow \infty} \left[ n \cdot \frac{1}{2} r^2 \sin \left( \frac{2\pi}{n} \right) \right] \\ &= \frac{r^2}{2} \lim_{n \rightarrow \infty} \frac{\sin \left( \frac{2\pi}{n} \right)}{\frac{2\pi}{n} \cdot \frac{1}{n}} \\ &= 2\pi \cdot \frac{r^2}{2} \lim_{n \rightarrow \infty} \frac{\sin \left( \frac{2\pi}{n} \right)}{\frac{2\pi}{n}} \\ &= \pi r^2 \end{aligned}$$

$n$ -sided regular polygon



# Unit H

## Extension Materials

Therefore, **CIRCLE** encloses maximum area under fixed perimeter.

**(3) The reasoning about Isoperimetric Problem is almost complete, except that in Unit 6, we have the assumption:**

**Under fixed perimeter and number of sides, there is a polygon with the greatest area.**

The following document provides a detailed discussion about the problem, which also proves the above assumption using advanced mathematics.



From the Triangle Inequality to  
the Isoperimetric Inequality



綜合科學科 第一層

校本全班式  
教學




Integrated Science  
Level 1

School-based  
Whole-class  
Teaching

# Making an Electric Circuit Game

**Grade: Secondary 2**

**No. of Lessons (Learning Time): 2 Lessons (110 minutes in total)**

<b>Prior Knowledge</b>	<ul style="list-style-type: none"><li>- Students understand the concepts of complete circuit</li><li>- Students understand the differences between series and parallel circuits</li></ul>
<b>Learning Objectives</b>	<ul style="list-style-type: none"><li>- Students should be able to apply the concepts and skills of electric circuit to make a game</li><li>- Students should be able to design their own games</li><li>- Students should be able to present their design and concepts applied</li></ul>
<b>Learning &amp; Teaching Strategies</b>	Questioning, Group Activity, Presentation
<b>Operation Mode of Gifted Education</b>	Level 1: School-based Whole-class Teaching
<b>Core Elements of Gifted Education</b>	<ul style="list-style-type: none"><li> Higher-order Thinking Skills</li><li> Creativity</li><li> Personal-social Competence</li></ul>

## Foreword / Background

Gifted education in Hong Kong aims to provide students, in particular those gifted / high ability, with opportunities to receive quality education in a flexible and versatile learning and teaching environment.

For the Project School concerned, students have interest in learning Science, being attentive and able to grasp the lesson content well. More challenging tasks can be provided to further stretch students' potential, which also enhances their sense of ownership and foster deeper engagement in learning. In this curriculum, the promotion of self-directed learning, enhancement of problem-solving skills, creativity and collaboration through challenging tasks are highlighted.

With reference to "Supplement to the Science Education Key Learning Area Curriculum Guide (Education Bureau, 2017)", the theme "Electricity" had been chosen for integrating STEM-related

activities. Six classes of Secondary 2 students participated in the implementation of the designed curriculum.

## Objectives of Collaboration

The collaboration focused on the development of an enriched curriculum of STEM education with real-world context. The learning content and activities were infused with the core elements of gifted education, namely higher-order thinking skills, creativity and personal-social competence, in order to unleash students' potential.

## Theoretical Framework

### 1. STEM education in Hong Kong

STEM is an acronym that refers to the academic disciplines of Science, Technology, Engineering and Mathematics collectively. The promotion of STEM education aligns with the worldwide education trend of equipping students to meet the changes and challenges in our society and around the world with rapid economic, scientific and technological developments.

STEM education aims to strengthen students' ability to integrate and apply knowledge and skills across different STEM disciplines, and to nurture their creativity, collaboration and problem-solving skills, as well as to foster their innovation and entrepreneurial spirit as required in the 21st century. These would provide quality learning experiences for students to enhance their interests, creativity and innovation, and to strengthen their ability in integrating and applying both knowledge and skills in solving authentic problems (Education Bureau, 2016).

### 2. Relationship between Gifted Education and STEM education

The implementation framework adapted the Level 1 school-based whole-class approach in Gifted Education. It seeks to infuse the three core elements of gifted education, namely higher-order thinking skills, creativity and personal-social competence, in regular classrooms for all students.

With the same goal and direction, STEM-related learning activities strengthen students' ability to integrate and apply knowledge and skills across disciplines to solve authentic problems. Students' problem-solving skills, creativity and collaboration skills are enhanced while potential in innovation is unleashed.

Core Elements of Gifted Education	Design of Programme in STEM Education
Higher-order Thinking Skills	Student-centred pedagogies, such as “design and make” activities, project-based and problem-based learning, employed in STEM education can facilitate students to integrate and apply knowledge and skills. Those hands-on and minds-on activities provide opportunities for students to demonstrate their higher-order thinking skills.
Creativity	Students have opportunities to provide innovative solutions for problems and make concrete inventions with hands-on and minds-on tasks. Creativity can be nurtured through active participation.
Personal-social Competence	Group activities (e.g. hands-on tasks and discussions) provide opportunities for gifted and high ability students to communicate and collaborate with peers.

### 3. 6E Learning by Design Model

**Engage:** To pique students’ interest and get them personally involved in the lesson, while pre-assessing prior understanding.

**Explore:** To provide students with an opportunity to construct their own understanding of the topic.


**Explain:** To provide students with an opportunity to explain and refine what they have learnt and what it means.

**Engineer:** To provide students with an opportunity to develop greater depth of understanding about the topic by applying concepts, practices, and attitudes. They use concepts about the natural world and apply them to the man-made (designed) world.

**Enrich:** To provide students with an opportunity to explore in greater depth on what they have learnt and transfer concepts to more complex problems

**Evaluate:** To allow both students and teachers to examine how much learning and understanding has taken place

## Curriculum Design

Phases of 6E Learning by Design Model	Content
EXPLORE	Designed situation - The school will have an Open Day for the public. Students are asked to prepare electric circuit games for the Open Day.
Creativity	<p>Prior to the lessons, individual students were provided with a self-directed learning opportunity to gain basic knowledge and skills by using electric parts, including a battery, battery box, conductive tapes and LED lights, to make a complete circuit. Students complete an individual proposal to design an electric circuit game based on those concepts.</p> 
EXPLAIN	Students work in groups. Groupmates share their proposals with one another, compromise the ideas and finalize the design. They draw the design and write the instructions of the game. The teacher gives them feedback for improvement.
ENGINEER	Students apply knowledge and skills to make their games by using materials provided by the teacher and collected by themselves. They engineer creative solutions through development, construction, refinement, assessment, and re-design. The teacher acts as a facilitator at this stage.
ENRICH	Students suggest the use of complete circuits in other new situations and applications in daily life.
EVALUATE	Students present their designs and demonstrate how to play the electric circuit games. Evaluation includes teacher feedback, peer assessment and self-reflection.

## Learning and Teaching Strategies

Students' knowledge and skills are constructed through a series of phases according to 6E Learning by Design Model. The core elements of Gifted Education are infused in suitable way in order to nurture and unleash students' potential.

In the design process, students design their electric circuit games by applying the concepts of complete circuit, including series and parallel circuits. They need to use their higher-order thinking skills (i.e. problem-solving skills) and creativity (i.e. originality). Students exchange ideas and experience in their groups, apply knowledge and skills in the process of making, and

try to achieve the best result by repeated verification and continuous improvement. Throughout the process, their higher-order thinking skills (i.e. investigative and problem-solving skills) and creativity (i.e. elaboration) are unleashed. Besides, they work collaboratively throughout the process to nurture their personal-social competence. Teacher, as a facilitator, encourages students to observe carefully, and use scientific methods and attitudes to analyze various scenarios.

## Discussion

Based on lesson observation, the effectiveness of the implementation of designed curriculum is summarized below:

### 1. Students showed high motivation and deeper engagement in learning

The designed curriculum encouraged students to apply and integrate knowledge and skills to solve a challenging problem in real-world context. The STEM-related activities were effective in stimulating students' motivation. Students' behaviors and body languages showed high level of engagement (e.g. eager to take up a role in the group) and enjoyment (e.g. smiling faces).

### 2. Students demonstrated higher-order thinking skills, creativity and personal-social competence

#### Higher-order Thinking Skills

Students were required to apply and integrate knowledge and skills in the STEM-related activities. During the “design and make” process, they came across a lot of challenging problems. For example, some materials were of poorer quality than expected and the LED light could not light up. Students showed their problem-solving skills by replacing copper foil by aluminum foil in making the ball as aluminum is a better conductor compared with copper.

#### Creativity

With open and challenging tasks, students demonstrated their creativity in designing the games, with the application and integration of knowledge and skills.

#### Personal-social Competence

Students had many opportunities to communicate and collaborate with peers as hands-on tasks and discussions were conducted in groups. They interacted and discussed with groupmates actively using suitable subject language.

### 3. Suggestions

To further refine the curriculum design and learning activities, more consideration can be placed on catering learners' diversity through applying differentiated instruction. To fully explore and develop the potential of gifted and high ability students, more opportunities could be provided in the class. For example, students can be invited to lead a learning activity in order to develop their leadership skills. They can also be asked to share the methods used to tackle technical problems in order to develop their communication skills.







# Lesson Plan

## Lesson 1

### Pre-lesson Task

Students bring 2 -3 pieces / pictures of disposed objects from home.

### Procedure

Learning Focus (Time)	Activity / Content	Learning & Teaching Strategies	Elements of GE	Learning & Teaching Resources
<b>Sharing of designs (55 minutes)</b>	<ol style="list-style-type: none"> <li>Each group does a trial of connecting the electric parts provided.</li> <li>Students in each group share their designs. They choose the best design or combine designs among groupmates, and propose a plan for the final design.</li> <li>Students share their proposal with the whole class. Teachers and other students give comments and feedback.</li> </ol>	<p>Group discussion</p> <p>Presentation</p> <p>Questioning</p>	  	<p>Pre-lesson Worksheet</p> <p>LED, conductive tapes, a battery with battery box</p> <p>Lesson Worksheet Marking Rubrics</p>
<b>Make the electric circuit games (55 minutes)</b>	<ol style="list-style-type: none"> <li>Each group builds the circuit according to the final design.</li> <li>Teacher identifies students' needs and gives assistance individually.</li> <li>Students tackle the problems during the process of making the games.</li> </ol>	<p>Questioning</p> <p>Group activity</p>	  	<p>LEDs, conductive tapes, 2 batteries and a battery box</p> <p>Completed Lesson Worksheet</p>

### Extended Learning Activity

Students make reflections on their performance and finish the Extension Worksheet.



# Lesson 1-2

## Pre-lesson Worksheet

### Making an Electric Circuit Game

#### Individual Proposal

##### Introduction

In this assignment, each group of students is provided with some electric parts, including a battery, a battery box, conductive tapes and LED lights. You are required to use these electric parts to design an electric circuit as a game for your classmates. (If you have no idea about the design, you may approach your teacher for suggestion.)

Your design will be shared with your classmates during the science lesson, and assessed by your teacher focusing on how you could apply the knowledge of electric circuit. The BEST design of your class will be chosen and a prize will be awarded. The marking rubrics are for your reference.

##### Proposal

1. Name of your design: \_\_\_\_\_

2. Write a brief description of your design.

---

---

---

3. List out the necessary electric parts in your design.

---

---

4. Draw a circuit diagram for your design.

# Lesson 1-2

## Pre-lesson Worksheet

5. Write an instruction for the game.

---

---

---

---

---

---

# Lesson 1-2

## Lesson Worksheet

### Making an Electric Circuit Game

#### Group Proposal

Each group of students has to discuss among groupmates and decide for ONE finalized design. You may combine designs from groupmates or choose one design as the finalized design. The marking rubrics are for your reference.

#### Finalized Design

1. Name of your design: \_\_\_\_\_

2. Write a brief description of your design.

---

---

---

3. List out the necessary electric parts in your design.

---

---

4. Draw a circuit diagram for your design.

# Lesson 1-2

## Lesson Worksheet

5. Write an instruction for the game.

---

---

---

---

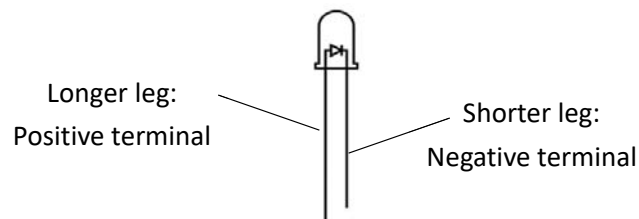
---

---

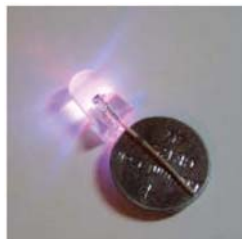
### Trial of Connecting the Electric Parts

Some electric parts will be provided to each group for doing a trial. The following are some remarks when connecting the electric parts.

1. Pay attention to the positive and negative terminals of the battery box and LED light. The polarities of the LED light is shown in the following diagram.



2. Test the LED lights before making the circuit by contacting the two terminals with a battery as shown in the following picture.



3. Be aware NOT to break the two legs of LED lights when bending.
4. The conductivity of the bottom of the conductive tape is not very good. You are advised to connect the electric part to the top of the conductive tape and stick another short conductive tape on the top to fix the position firmly. (Just like a sandwich!)
5. Check the contact between the conductive tape and electric parts if the circuit does not work.

# Lesson 1-2

## Marking Rubrics

Name of student		
Name of design		
Creativity		
Original design (Max: 5 marks)		/5
Modified from teacher's suggestion (Max: 3 marks)		
Follow teacher suggestion (0 marks)		
Proposal		
Description	/2	/12
Necessary electric parts	/2	
Electric diagram	/5	
Instruction	/3	
Electric circuit design		
Feasibility	/6	/10
Use of conductive tape	/1	
Use of LED lights	/1	
Use of switch	/1	
Use of parallel circuit	/1	
Level of difficulty (max 5 marks)		/5
Presentation (max 5 marks)		/5
Participation (max 3 marks)		/3
<b>Total</b>		<b>/40</b>

# Lesson 1-2

## Extension Worksheet

### Making an Electric Circuit Game

#### Self-reflection

1. What is the most challenging problem in designing the circuit?

---

---

---

---

2. How did you solve the above problem?

---

---

---

---

3. What is your most significant contribution in the group?

---

---

---

4. Who will you choose as the best groupmate? Which of his / her qualities impresses you the most?

---

---

---

綜合科學科 第二層

# 校本抽離式 計劃

Integrated Science  
Level 2

School-based  
Pull-out Programme

# Wearable Electronic Clothes

**Grade: Secondary 2**

**No. of Lessons (Learning Time): 6 Lessons (540 minutes in total)**

<p><b>Prior Knowledge</b></p>	<ul style="list-style-type: none"> <li>- Students understand the concepts of complete circuit</li> <li>- Students understand the differences between series and parallel circuits</li> </ul>
<p><b>Learning Objectives</b></p>	<ul style="list-style-type: none"> <li>- Students should be able to apply the concepts and skills of the following:                      Science: Concepts and skills in connecting electric circuits                      Information and Communication Technology: Programming with mBlock                      Math: Basic Mathematical concepts and computation thinking                      Visual Art: Designing and decorating the wearable electronic clothes</li> <li>- Students should be able to design their own wearable electronic clothes</li> <li>- Students should be able to present their design and concepts applied</li> <li>- Students should be able to demonstrate their scientific inquiry, computational thinking, critical thinking, problem-solving skills and creativity</li> </ul>
<p><b>Target Students</b></p>	<p>S2 students with outstanding performance in STEM education and related subjects, especially in Science.</p>
<p><b>Learning &amp; Teaching Strategies</b></p>	<p>Questioning, Hands-on Group Activities, Presentation / Performance</p>
<p><b>Operation Mode of Gifted Education</b></p>	<p>Level 2: School-based Pull-out Programme</p>



## Foreword / Background

For the Project School concerned, students have interest in learning Science. Some gifted / high ability students demonstrated their potentials in school-based whole-class learning (L1 of Gifted Education) on the topic “Making an Electric Circuit Game”. Hence, a pull-out programme is designed as an extension of the regular curriculum to further foster their talent. This pull-out programme of STEM education is a ‘Design and Make’ project on wearable electronic clothes.

Generally speaking, gifted students are strongly sensitive about problems, and their analytical and integrating abilities are greater. They also enjoy thinking on a broader scale and show particular interest in activities that require observation and exploration. Therefore, project learning is an ideal learning mode for them as it provides flexible learning opportunities. In this project, a series of activities is used to teach gifted students how to grasp knowledge in different areas, and to give full play to their potentials in various aspects, such as integration, application, analysis and evaluation. It also helps develop student’s creativity, critical thinking and problem-solving skills.

## Objectives of Collaboration

The collaboration aims to tailor-make a pull-out STEM education programme for talent development of a group of gifted / high ability students. With the understanding of their performances and characteristics, advanced content, creativity, critical thinking and problem-solving skills are integrated in the curriculum.

## Criteria for Selection of Students

Students are selected based on their performance in the school-based whole-class learning (L1 of Gifted Education) on the topic “Making an Electric Circuit Game”, and their personal interest and performance in science assessment. In connection to multiple intelligences, their logical-mathematical and visual-spatial intelligences are also considered.

### 1. Behavioural characteristics of students with high potential in Science (Education Bureau, 2017)

- Persistent in learning science, high concentration, hard-working and motivated
- Interested in science books and science related television programmes or videos
- Enjoy solving problems in science
- Organize data or analyze an observed phenomenon to discover patterns or relationships
- Good at observing, exploring, questioning, investigating things in detail
- Understand scientific methods, able to formulate hypotheses and conduct experiments carefully
- Skillful in using laboratory equipment, able to improvise with science equipment
- Demonstrate creativity in invention and/or experimental designs

- Demonstrate task commitment in science projects (sticking with investigations in spite of difficulties or problems)

## 2. Criteria for selection for the STEM education pull-out programmes

Teachers are advised to use multiple methods and channels, such as classroom observation, behavioural information, parent / peer groups, self-recommendation, students' products and assignments, awards in local and/or international science competitions, to select students with high potential in Science (one of the subjects in STEM education) to take part in the school-based pull-out programme. A single test or tool is not reliable in the identification of a scientifically gifted student.

## Theoretical Framework

### 1. Curriculum design for pull-out programmes

According to Gallagher (1985), the learning content, process and environment of the basic curriculum need to be modified to match the characteristics and the needs of the gifted / high ability students. VanTassel-Baska et al. (1988) advocated that a gifted curriculum should attend to the content mastery and the learning process. Hence, gifted students should be taught with advanced content, higher-order thinking and problem-solving skills.

STEM education aims to strengthen students' ability to integrate and apply knowledge and skills across different STEM disciplines, and to nurture their creativity, collaboration and problem-solving skills, as well as to foster their innovation and entrepreneurial spirit as required in the 21st century. These would provide quality learning experiences for students to enhance their interests, creativity and innovation, and to strengthen their ability in integrating and applying both knowledge and skills in solving authentic problems (Education Bureau, 2016).

### 2. STEM education in Hong Kong

STEM is an acronym that refers to the academic disciplines of Science, Technology, Engineering and Mathematics collectively. The promotion of STEM education aligns with the worldwide education trend of equipping students to meet the changes and challenges in our society and around the world with rapid economic, scientific and technological developments.

STEM education aims to strengthen students' ability to integrate and apply knowledge and skills across different STEM disciplines, and to nurture their creativity, collaboration and problem-solving skills, as well as to foster their innovation and entrepreneurial spirit as required in the 21st century. These would provide quality learning experiences for students to enhance their interests, creativity and innovation, and to strengthen their ability in integrating and applying both knowledge and skills in solving authentic problems (Education Bureau, 2016).

### 3. 6E Learning by Design Model

- Engage:** To pique students' interest and get them personally involved in the lesson, while pre-assessing prior understanding.
- Explore:** To provide students with an opportunity to construct their own understanding of the topic.
- Explain:** To provide students with an opportunity to explain and refine what they have learnt and what it means.
- Engineer:** To provide students with an opportunity to develop greater depth of understanding about the topic by applying concepts, practices, and attitudes. They use concepts about the natural world and apply them to the man-made (designed) world.
- Enrich:** To provide students with an opportunity to explore in greater depth on what they have learnt and transfer concepts to more complex problems
- Evaluate:** To allow both students and teachers to examine how much learning and understanding has taken place

### Curriculum Design

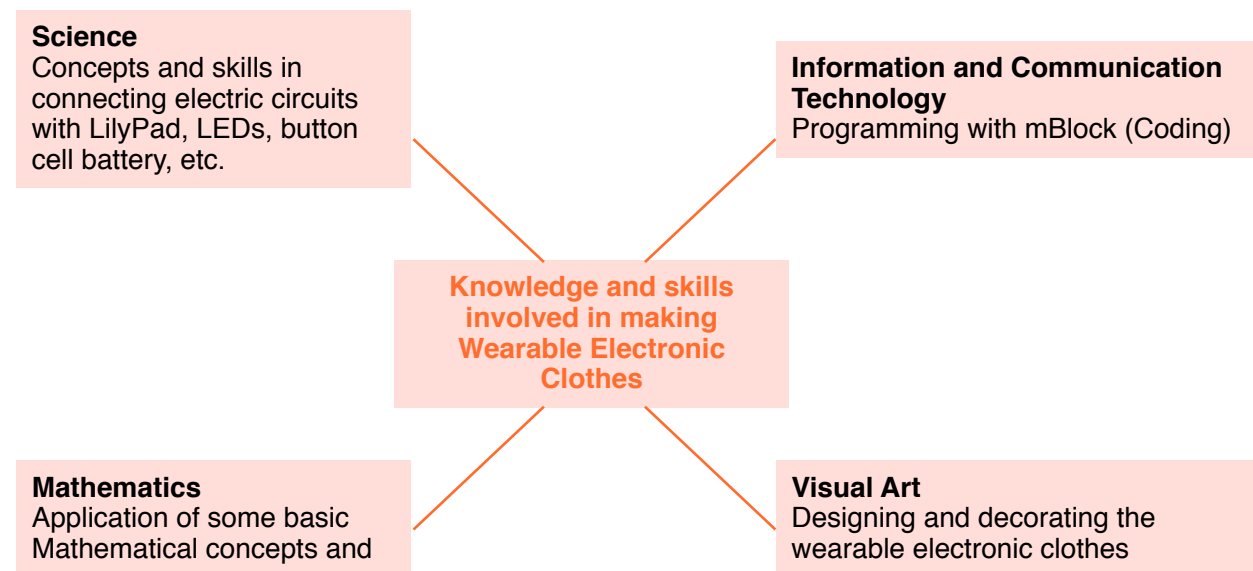
Lessons	Main Focus
1 - 2	Workshops - Students learn the required skills for the successful completion of the 'Design and Make' Project. The hands-on skills to prototype designs are taught. Topics include circuit design, soldering, Arduino coding etc. The workshops are conducted by two S5 student instructors.
3 - 6	'Design and Make' Project - It requires students to develop custom electrical, mechanical, and software components. The project includes design and making processes.  In the design process, students design their wearable electronic clothes by applying the concepts of the electric circuit, coding, art etc. In the making process, students apply knowledge and skills in making clothes. With repeated verification and continuous improvement, students try to achieve the best result. Teacher, as a facilitator, encourages students to observe carefully and use effective questioning techniques to promote higher-order thinking.
<b>Showcase</b> Presenting the final products in a live fashion show	

## Learning and Teaching Strategies

“Wearable Electronic Clothes” is the theme of this STEM education pull-out programme. The programme aims to provide Secondary 2 students with high potential in science and programming with advanced learning content, develop their scientific inquiry, computational thinking, critical thinking, problem-solving skills, and creativity. 6E Learning by Design Model which provides a student-centred framework for instruction may help foster the potential of gifted / high ability students.

The curriculum involves the application and integration of knowledge and skills across subjects, to make wearable electronic clothes using LilyPads, LED lights, conductive thread and other electric parts. Students are more motivated to learn the advanced and challenging content, compared to the usual subject curricula at their age level. Moreover, the content consists of real-world contexts involving interdisciplinary subject knowledge and skills. It can nurture the learning needs of gifted / high ability students.

The interdisciplinary subject knowledge and skills involved:



Students apply knowledge and skills through a series of phases according to 6E Learning by Design Model:

Phases of 6E Learning by Design Model	Content
ENGAGE	Workshops - Students learn the required skills for the successful completion of the 'Design and Make' Project. The hands-on skills to prototype designs are taught. Topics include circuit design, soldering, Arduino coding etc. The workshops are conducted by two S5 student instructors.
EXPLORE	Prior to the lessons, individual students were provided with a self-directed learning opportunity to gain basic knowledge and skills of LilyPad. Students participate in workshops to learn programming with mBlock.
EXPLAIN	Students work in pairs to discuss their designs with the knowledge and skills learnt.
ENGINEER	Students apply knowledge and skills to make their wearable electronic clothes by using materials provided by the teacher and collected by themselves. They engineer creative solutions through development, construction, refinement, assessment, and re-design. The teacher acts as a facilitator at this stage.
ENRICH	Students suggest the use of concepts in other new product designs.
EVALUATE	Students present their products in the fashion show. Evaluation is based audience feedback and self-reflection.

The teacher should act as a facilitator to motivate students to learn actively, and may use effective questioning techniques to promote higher-order thinking. Last but not least, the teacher should maintain a warm classroom atmosphere so as to encourage more teacher-student and student-student interaction, which is beneficial to learn in depth.

## Discussion

The programme proves that by providing a suitable learning environment, together with activities and teaching strategies that suited the needs of students, students can build their knowledge and skills of STEM education through 'Design and Make' projects. Students can cultivate a persistent spirit of exploration, understand the close relationships between STEM education and daily life, as well as improve the quality of life by applying and integrating knowledge and skills.

Based on lesson observation, the effectiveness of the implementation of designed curriculum is shown:

### 1. Students were devoted in learning

Gifted / high ability students were more than happy to take up the challenges.

## 2. Students abilities can be demonstrated and stretched

### Mastering of knowledge and skills in advanced content

Through a series of activities, students were motivated to learn about and explore the theme “Wearable Electronic Clothes” from integrated perspectives. Not only could they grasp subject knowledge and skill, they were also empowered to apply the skills they had learnt. They had a comparatively more extensive and deeper understanding of some concepts and skills of STEM education. Moreover, their creativity, critical thinking and problem-solving skills were developed throughout the learning process.

Students can master the skills of using basic electric parts and programming quite well after participating in workshops with the accelerated curriculum. When opportunities were provided for them to make greater use of their abilities, they experienced a heightened sense of satisfaction and enjoyment.

### Creativity shown in the designs

Through the project, students were able to design and make clothes based on their own interests. Many of the products were very creative. From their selection of colour and design, the deep meanings of their product are shown.

## 3. The teacher acted as a facilitator

Students were encouraged by the teacher to learn through facing new challenges, daring to try, thinking comprehensively, and grasping the higher-order thinking skills related to the learning project. The teacher acted as a facilitator by asking effective questions.

# Lesson Plan

## Lessons 1 - 2

### Pre-lesson Task

Students get to know about LilyPad by reading the Information Sheet provided by the teacher and searching online.

Learning Focus (Time)	Activity / Content	Teaching Strategy	Learning & Teaching Resources
<b>Students learn programming with mBlock (3 hours)</b>	<ol style="list-style-type: none"> <li>Two S5 student instructors are responsible for the workshops. They teach S2 students basic programming with mBlock.</li> <li>S2 students learn and practise by writing some programmes to control the patterns of blinking of LEDs.</li> <li>S2 students start to design and write their own programmes for LilyPad.</li> <li>Each group does a trial of connecting the electric parts to build a circuit. At last, they try to test the programmes by using LilyPad</li> </ol>	<p>Group discussion</p> <p>Presentation</p> <p>Questioning</p>	<p>LilyPads, LEDs, conductive thread, button cell battery, etc.</p> <p>Powerpoint</p>

## Lessons 3-6

Learning Focus (Time)	Activity / Content	Teaching Strategy	Learning & Teaching Resources
<b>Students design and make their wearable electronic clothes (6 hours)</b>	<ol style="list-style-type: none"> <li>Students work in pairs to write the programmes and build the circuit according to their designs.</li> <li>Teacher asks effective questions to stimulate students' thinking.</li> <li>Teacher identifies students' need and gives assistance to individual students.</li> <li>Students tackle the problems during the learning process.</li> </ol>	<p>Questioning</p> <p>Group activity</p>	<p>LilyPads, LEDs, conductive thread, button cell battery etc.</p> <p>Worksheet (1) &amp; (2)</p>

### Extended Learning Activity

Students showcase and present their final products in a live fashion show. After the show, they can complete the Extension Worksheet for self-reflection.

# Lessons 1-2

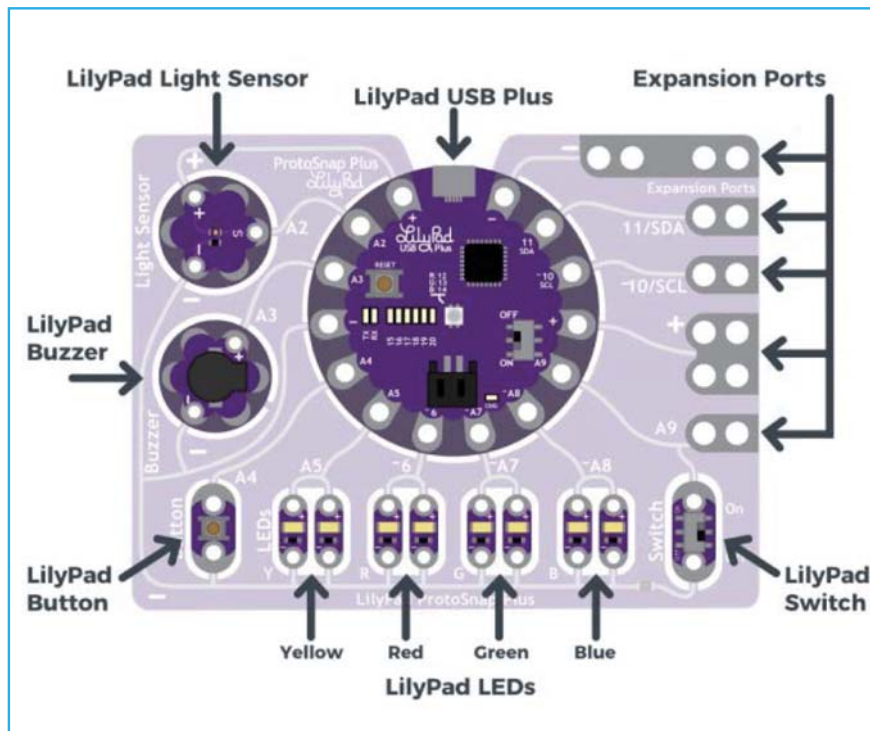
## Information Sheet

### Wearable Electronic Clothes

#### Information Sheet of LilyPad

The LilyPad system is a set of sewable electronic pieces designed to help you build soft, sewable, interactive e-textile (electronic textile) projects.

#### 1. Components of a LilyPad Set



Source: <https://learn.sparkfun.com/tutorials/adapting-lilypad-development-board-projects-to-the-lilypad-protosnap-plus>

#### 2. LilyPad Circuit

Every LilyPad circuit, no matter how complex it is, has three basic parts: (1) a power source, (2) conductive paths (conductive thread stitching) between electronic components, and (3) the LilyPad pieces that are connected together to light up, make sound or perform other behaviors (the “function” of your project).

#### 3. Project Planning Checklist

Please read a checklist of questions to consider online when planning for the specifics of your project: <https://learn.sparkfun.com/tutorials/planning-a-wearable-electronics-project>



# Lesson 3-6

## Lesson Worksheet 1

### Wearable Electronic Clothes

#### 'Design and Make' Process

1. Write down the function(s) that you want to use to design your clothes.

(Remark: You need to programme the LEDs to blink with different patterns.)


---

---

---

---

2. Draw the design of your circuit(s).



3. Practical work: Write the program(s) to achieve the features mentioned above.

(Remark: Use the programming skills you have learnt in the previous workshops or find new information from the internet.)

4. Practical work: Try to make the circuit according to the design.

5. Improve your design.

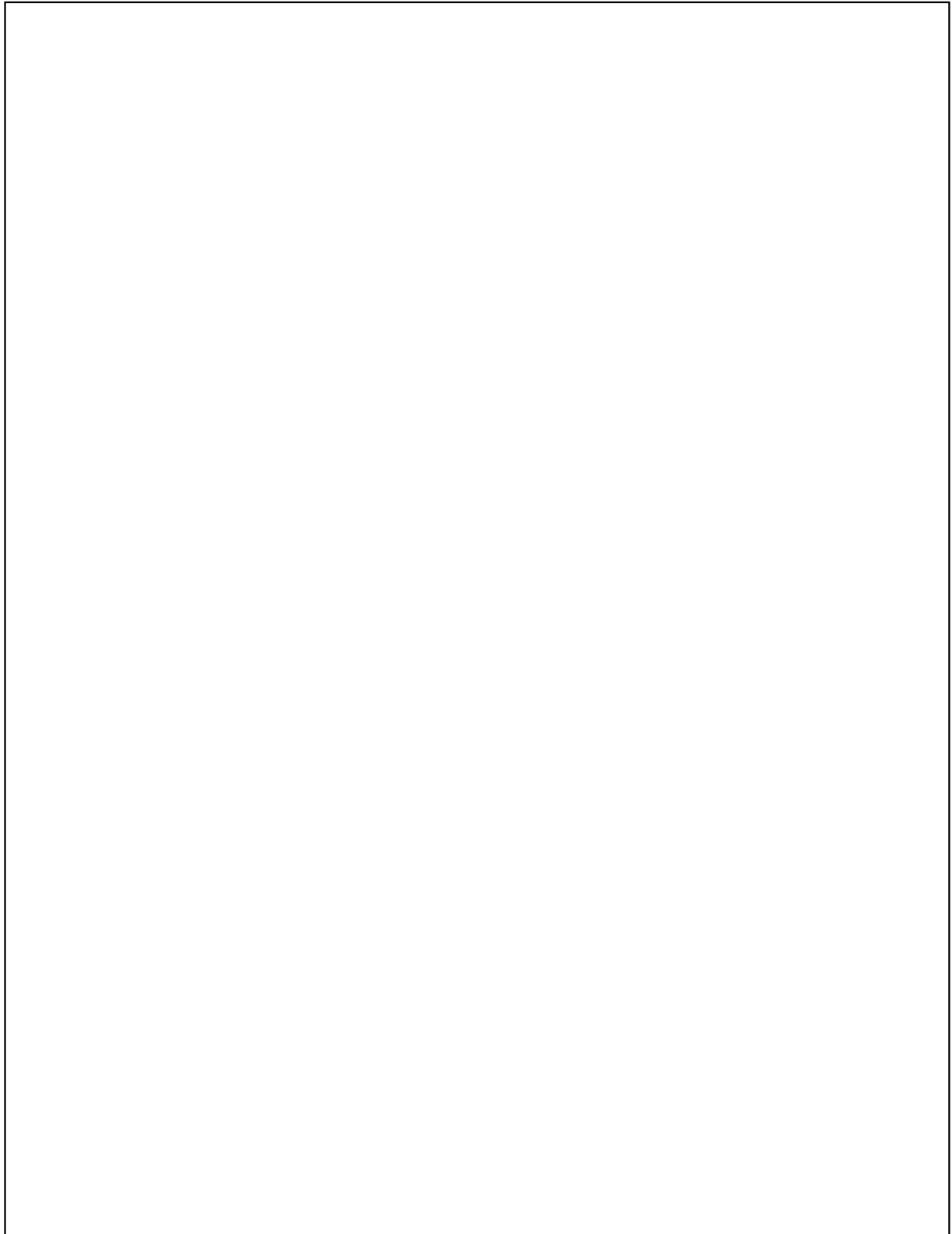
# Lesson 3-6

## Lesson Worksheet 2

### Wearable Electronic Clothes

#### Our Design

Draw and label the design of your wearable electronic clothes.



## Extension Worksheet

### Wearable Electronic Clothes

#### Self-reflection

1. What is the most challenging problem in designing the clothes?

---

---

---

---

2. How did you solve the above problem?

---

---

---

---

3. What is your most significant contribution in the group?

---

---

---

4. Who will you choose as the best groupmate? Which of his / her qualities impresses you the most?

---

---

---

# 總結

在過去兩年的校本專業支援和協作，計劃學校的教師在課程規劃中融入資優教育的核心元素有更深的認識，亦大大提升相關技巧。隨著校本專業支援和協作將完成，計劃學校的成功實例和豐碩的成果結集成《校本資優教育：學與教資源套》。

本章節會重點歸納在此資源套提及到支援資優學生的教學經驗和策略，而且會採用實證為本的方法以量度課程的效能。根據實際經驗和計劃的成效檢討，本章節另一個重點將放在分享成功經驗，了解為資優學生制定課程時的主要考慮。總括而言，**賽馬會「知優致優」計劃**預期透過本地學校間的經驗分享，能協助推動校本資優教育的發展。

## 支援資優學生的教學實踐和策略

其中一個明顯的特點是計劃學校大部分教師的專業能力都大幅提升，並且能夠將高層次思維技巧、創造力及個人及社交能力的元素融入至常規課堂中 (L1)。正如資優教育的三層架構推行模式所述，教師要在全班式教學的增潤課程中盡力利用有效的教學法，激發學生在創造力、批判性思考能力、解難能力及領導能力的潛能，涵蓋科目包括小學的中文教育、英文教育、數學教育和常識科，以及中學的數學教育和科學/STEM教育。

把資優教育核心元素融入常規課堂的確能對學生帶來正面的影響，針對學生對L1課程主觀成果評估的反應，進行評估分析，以檢討計劃的成效。約80%參與的學生認為課程有助加強他們解難力、分析力和創造力，而且大部分都認同課堂能夠有效地提升社交能力，協助他們增進與同學間的關係。同樣地，教師亦持正面的評價，認為L1計劃讓學生得益不少。整體而言，超過90%參與的教師認同課堂能夠滿足學生的學術發展需要，加深學生對各個科目的興趣、知識和技巧，推動他們學習。最重要的是教師發現計劃成功地加強學生的解難力、分析能力、創造力和社交能力，亦教導了學生如何自主學習。

適異性是其中一個有效的教學實踐和策略，教師一般而言都擁有足夠的能力應用適異性的教學策略以照顧學習差異，尤其是照顧資優和高能力學生獨特的學習和情意需要。使用過的適異課程、教學法和評估模式，均收錄在此資源套中。教師普遍都會以加速法和增潤法編排課程、規劃課堂及為資優學生進行分組。

在加速課程，資優學生會比朋輩以更快的速度學習標準或常規課程；在增潤課程，資優學生會學習「比常規課程更深入或廣闊的延伸或補充部分，而且會為資優學生提供更豐富和多元化的教育經驗」(Chan, 2018, p.75)。建基於資優教育的三大元素

(Renzulli, 1978) 的理論上，適異課程能夠解決到資優學生的需要，同時亦可以照顧常規課堂上不同類型的學生，以及他們擁有的不同學習模式、期望和能力。此外，適異課程的教學步伐、策略、內容及評估，有助加強學習決心和課堂參與，亦提升資優和高能力學生的創造力。

在規劃為所有學生而設的L1增潤課程時，本計劃與教師合作，研究校本搜尋人才的準則和挑選高能力和資優學生的程序。此舉有助教師透過數據分析和科學的方法，辨認校內資優和具潛能的學生。因此根據個別學校的長處及學生特別的需要和特質，設計了一系列的抽離式計劃，為學生提供延伸學習機會，包括語文科的創意寫作、數學及科學科的增潤課程及STEM教育。

為了增加資優和高能力學生的挑戰感，以及支援他們將資優能力發展成優秀的才能（教育局，n.d.），教師在L2的抽離式計劃特別設計進階內容，並加入一些具挑戰性的作業。學生和教師進行的自我評估都對這些計劃持正面評價，因此學生普遍對豐富、複雜和富挑戰性的課程感到滿意。其中一個有趣的發現是所有參與的學生都表示，課程有助他們掌握新知識和技巧，以及提升學習興趣和動機。大部分參與的學生反映，計劃有效地加強高層次思維技巧（解難能力、分析能力）、創造力及社交能力。至於情意範疇，很多學生重視反思，並且能夠在學習過程中展現同情心、毅力、懂得感恩及關心和尊重他人，而他們其中的一些學習成果也收錄在資源套中。

### 為資優學生設計課程的考慮

就實際經驗和教師反思所得出設計資優教育課程的主要考慮，值得課程發展人員和前線教師參考，因此接下來將會提出幾項考慮範圍。第一項而且最重要的考慮是「不斷強調運用高層次思維技巧（如批判性思考、創意思考解難能力），以運用這些技巧在適當的地方」（VanTassel-Baska, 2018, p.349）。基於資優學生學習速度都較快，而且能夠更深入和複雜地了解內容，因此教師必須多加注意教授進階內容和具挑戰性的作業，加強學生參與，以及發展他們的潛能。

將情意範疇的元素融入課程中，對照顧資優學生的情意需要和特質都是十分重要的。VanTassel-Baska (2018) 建議「在資優教育課程加入創造力的元素，可以加強與情意發展的連繫」（p.349）。透過把情意教育融入創意力相關的增潤課程，製造合適的氛圍以照顧學生的學習差異，並且鼓勵學生發展自我認知、情緒表達和管理技巧及社交和領導能力，因為這些對個人成長和全人發展都是重要的特質。

除了情意教育外，VanTassel-Baska (2018) 提到高能力和資優學生亦需要具備倫理道德的領導才能，以裝備自己貢獻社會，而課程內道德困境實驗和情商發展會讓資優學生有所得益。情商是一個人「接受和表達情緒的能力，懂得如何運用不同情緒，並管

理情緒以促進個人發展」(Salovey, Bedell, Detweiler & Mayer, 2000, p.506)。因此，在課程融入道德和倫理議題尤其重要，可以讓進階的學生發展人際關係及內省智能。

總括而言，計劃得以成功推行並出版《校本資優教育：學與教資源套》，實在有賴多方面的合作。首先，計劃團隊衷心感謝香港賽馬會慈善信託基金的慷慨捐助，以致計劃成功推展。另外，賽馬會的捐助讓香港中文大學、香港理工大學、香港城市大學和香港教育大學組成跨院校研究團隊，推動校本才能發展和香港資優教育的發展，讓計劃為本地學校、學生、教師和家長帶來重大得益。

計劃團隊亦非常感激所有計劃學校在整個計劃期間的鼎力支持和配合，多得他們的專業、毅力、真誠和積極參與，計劃才能獲得豐碩的成果。最後，我們希望此系列的資源套能啟發教師，帶領他們踏上才能發展和香港資優教育的成功之路。如各教育同工有興趣了解更多，歡迎瀏覽賽馬會「知優致優」計劃的網址 (<https://www.fed.cuhk.edu.hk/gift>)。

## Conclusion

During the two years of school-based professional support and collaboration, teachers of the Project Schools generally showed enhanced knowledge of and skills for nurturing the core elements of gifted education in the curriculum plan and implementation. Upon completion of the school-based professional support and collaboration, their successful practical experiences with fruitful learning outcomes are recorded and collected in this *School-based Gifted Education: Learning and Teaching Resource Package*.

This chapter summarizes the key features of instructional practices and teaching strategies to support gifted learners, as reported in this learning and teaching resource package. To gauge curriculum effectiveness, an evidence-based approach will be used. Based on practical experiences and Project evaluation, another focus of this chapter will be on sharing good practice as a major consideration for developing curriculum for gifted learners. Overall, it is expected that the Project will play a contributing and motivating part in promoting school-based gifted education through dissemination of successful practices among local schools.

### Instructional Practices & Teaching Strategies to Support Gifted Learners

One of the very evident features was that most of the teachers of the Project Schools showed enhanced capacity and mastery of skills in integrating higher-order thinking, creativity skills and personal-social abilities into regular classroom settings (L1). Specifically, as proposed by the Three-tiered mode of gifted education, teachers were, to the greatest extent, capable of employing effective pedagogies to tap the potential of students in creativity, critical thinking, problem solving as well as leadership skills through an enriched curriculum for whole-class teaching for Chinese Language Education, English Language Education, Mathematics Education and General Studies in primary schools, and Mathematics Education and STEM Education in secondary schools.

The integration of core elements of gifted education into regular lessons has indeed generated positive impacts on students. Evaluation analysis based on students' responses to subjective outcome evaluation on L1 curriculum indicated the programme's effectiveness. Approximately 80% of the student participants found the curriculum effective in strengthening problem-solving, analytical, and creativity skills. Moreover, many of them reported the usefulness of the lessons in enhancing social competence and developing better relationships with their classmates. Similarly, teachers gave positive views on the benefits of students in L1 programmes. On the whole, over 90% of the teacher participants agreed that the lessons satisfied the academic needs of the students, who showed enhanced interest, knowledge and skills in the subjects, and learning motivation. Most importantly, teachers found the programmes successful in strengthening problem

solving, analytical ability, creativity and social competence. Overall, the programme taught students how to become self-directed learners.

One effective instructional practice and teaching strategy was differentiation. In general, teachers demonstrated stronger competence in adopting differentiation to address the issue of learner diversity, notably to meet the unique learning and affective needs of the gifted and high-ability students. Differentiated curriculum, instruction and assessment were attempted and recorded in this resource package. It was common to see that teachers organized curriculum and lesson plans and grouping for gifted children in terms of acceleration and enrichment.

Offered acceleration, gifted students would learn the standard or regular curriculum faster than their average peers. Regarding enrichment, the gifted were offered “extending, supplementing, and going beyond the regular curriculum in greater depth or breadth, and thus gifted learners are provided with richer and more varied educational experiences” (Chan, 2018, p.75). Grounded in the Three-Ring Conception of Giftedness (Renzulli, 1978), differentiation can both satisfy the needs of the gifted learners and cater for learner diversity in regular classes with diverse learning styles, aspirations and abilities. In addition, differentiated instructional pace, approach or content as well as assessment can help to foster stronger commitment and class engagement, and enhance creativity among students with giftedness and advanced learning abilities.

Furthermore, in developing an L1 enriched curriculum for all students, the Project worked in partnership with teachers to explore school-based talent search criteria, guidelines, and procedures for selecting high ability and gifted students. Such attempts facilitated teachers to identify gifted and talented learners in their respective schools through a data-informed and scientific method. As a result, based on individual schools’ strengths and students’ unique needs and characteristics, a wide range of pull-out programmes was designed to provide extended learning opportunities in the areas of creative writing in languages, mathematics and science enrichment, and STEM education.

To challenge the gifted and high-ability learners and to support them to develop their giftedness into flourishing talents (Education Bureau, n.d.), teachers tailor-made advanced content with challenging tasks in L2 pull-out programmes. In brief, the programmes were well received with positive feedback from self-reported evaluations of students and teachers. Generally speaking, the students appreciated the rich, complex and challenging curriculum. It is interesting to find that all of the student participants mentioned that the curriculum helped them to master new knowledge and skills, and enhanced their learning interest and motivation. A great majority of them reported that the programme was successful in strengthening higher order thinking (problem-solving, analytical thinking), creativity, as well as social competence. For the affective domain, many students valued reflection and showed the qualities of sympathy, gratefulness, perseverance, and concern and respect for others in the learning process. Some of their learning outcomes were collected in the resource package.



## Considerations for Developing Curriculum for Gifted Learners

Based on practical experiences and teachers' reflection, some key considerations for developing gifted education curriculum are recommended for curriculum developers and frontline teachers. In the following, several considerations will be suggested. The first and most essential consideration is a "consistent emphasis on using higher level skills (e.g., critical and creative thinking and problem solving that result in applications to worthy products" (VanTassel-Baska, 2018, p.349). Given that gifted students learn consistently faster, and that they can grasp content at a deeper and more complicated level, teachers must be mindful of providing the advanced content and challenging tasks to engage them in instruction, and most importantly, to stretch their potentials.

Likewise, to meet the affective needs and characteristics of gifted learners, it is important to immerse an affective emphasis into the curriculum. VanTassel-Baska (2018) advised that "the infusion of creativity into a gifted curriculum may ensure greater connectivity to affective development" (p.349). By integrating affective education into a creativity-enriched curriculum and given an accepting atmosphere to embrace learner diversity, students can be encouraged to develop self-understanding, emotion expression and management, as well as interpersonal and leadership skills. These are essential qualities for personal growth and balanced development of individuals.

In addition to affective development, VanTassel-Baska (2018) noted that it is crucial to infuse ethical and moral leadership into high ability and gifted learners who are ready to make societal contributions. Gifted students may benefit from a curriculum with moral dilemmas as well as the development of emotional intelligence. Emotion intelligence is one's "ability to perceive and express emotions, to understand and use them, and to manage emotions so as to foster personal growth" (Salovey, Bedell, Detweiler, & Mayer, 2000, p.506). Therefore, the immersion of moral and ethical issues is especially important for advanced learners to develop interpersonal and intra-personal intelligences.

In summary, for the successful programme implementation and publication of this *School-based Gifted Education: Learning and Teaching Resource Package*, the Project is greatly indebted to various parties. First of all, the Project would like to extend its deepest gratitude to the Hong Kong Jockey Club Charities Trust. Its generous and unfailing support was vital to the effective implementation of the Project. In addition, due to its fund donation, the research investigators from the Chinese University of Hong Kong, the Hong Kong Polytechnic University, the City University of Hong Kong and the Education University of Hong Kong could take a crossinstitutional approach in promoting school-based talent development and Hong Kong's gifted education, and most importantly, make this Project rewarding and beneficial to local schools, students, teachers and parents.

Most important of all, the Project is extremely grateful to all the Project Schools for their cordial partnership and effective collaboration during the Project period. Without their expertise,

perseverance, sincerity, and professional participation, the Project would not have been accomplished with such fruitful success and beneficial outcomes. Last but not least, we hope that this series of resources packages gives teachers inspiration leading them on a successful path to talent development and gifted education in Hong Kong. Interested educators are invited to visit the website of Project GIFT (<https://www.fed.cuhk.edu.hk/gift>) for further details.

## References

- Anderson, L. W., Krathwohl, D. R., Airasian, P. W., Cruikshank, K. A., Mayer, R. E., Pintrich, P. R.,... Wittrock, M. C. (Eds.). (2001). *A taxonomy for learning, teaching, and assessing: A revision of Bloom's taxonomy of educational objectives*. (Complete edition). New York: Longman.
- Assouline, S. G., Colangelo, N., & VanTassel-Baska, J. (2015). *A nation empowered: Evidence trumps the excuses holding back America's brightest students*. Iowa City, IA: Connie Berlin & Jacqueline N. Blank International Center for Gifted Education and Talent Development.
- Bloom, B. S. (Ed.), Engelhart, M. D., Furst, E. J., Hill, W. H., & Krathwohl, D. R. (1956). *Taxonomy of educational objectives: The classification of educational goals. Handbook 1: Cognitive domain*. New York: David McKay Co., Inc.
- Brody, L., & Benbow, C. (1987). Accelerative strategies for the gifted: How effective are they? *Gifted Child Quarterly*, 3, 105-110.
- Burke, B. N. (2014). The ITEEA 6E learning by DeSIGN™ model, maximizing informed design and inquiry in the integrative STEM classroom. *Technology and Engineering Teacher*, 73(6), 14-19.
- Chan, D. W. (1999). Counselling gifted students in Hong Kong: A critical need. *Educational Journal*, 27(2), 145-154.
- Chan, D. W. (2003). Adjustment problems and multiple intelligences among gifted students in Hong Kong. The development of the revised Student Adjustment Problems Inventory. *High Ability Studies*, 14(1), 41-54.
- Chan, D. W. (2008). Gifted education in China: Reflections and challenges. In S. T. Hann & M. W. Lewis (Eds.), *Education in China: 21st century issues and challenges* (pp. 39-59). Hauppauge, NY: Nova and Science.
- Chan, D. W. (2018). Gifted education in Asia. In S. I. Pfeiffer (Ed.), *APA handbook of giftedness and talent* (pp. 71-84). Retrieved from <http://dx.doi.org/10.1037/0000038-024>
- Education Bureau. (n.d.). *Chapter 2: Content and implementation mode of school-based gifted development programmes*. Retrieved from <https://www.edb.gov.hk/en/curriculum-development/major-level-of-edu/gifted/guidelines-on-school-based-gifted-development-programmes/chapter-two.html>
- Education Bureau. (2016). *Report on promotion of STEM education: Unleashing potential in innovation*. Hong Kong: Hong Kong Government.
- Education Bureau. (2017a). *Mathematics education key learning area curriculum guide (Primary 1 - Secondary 6)*. Hong Kong: Hong Kong Government.
- Education Bureau. (2017b). *Supplement to the science education key learning area curriculum guide*. Hong Kong: Hong Kong Government.
- Education Bureau. (2019). *Gifted Education*. Retrieved from <http://www.edb.gov.hk>

- Education Commission. (1990). *Education Commission Report No.4*. Hong Kong: Hong Kong Government.
- Education Department. (2000). *The development of gifted education in Hong Kong*. Hong Kong: Hong Kong Government.
- Feldhusen, J. (1982). Meeting the needs of gifted students through differentiated programming. *Gifted Child Quarterly*, 26, 37-41.
- Feldhusen, J., Hansen, J., & Kennedy, D. (1989). Curriculum development for GCT teachers. *Gifted Child Today Magazine*, 12(6), 12-19.
- Gallagher, J. J. (1985). *Teaching the gifted child* (3rd ed.). Boston: Allyn and Bacon.
- Gardner, H. (1983). *Multiple intelligences: The theory in practice*. New York: Basic Books.
- Gardner, H. (1999). *Intelligence reframed: Multiple intelligences for the 21st century*. New York: Basic Books.
- Gavin, K. M. (2016). Mathematics curriculum for gifted learners. In K. R. Stephens & F. A. Karnes (Eds.), *Introduction to curriculum design in gifted education* (pp. 151-174). Waco, TX: Prufrock Press.
- Griggs, S. A., & Dunn, R. S. (1984). Selected case studies of the learning style preferences of gifted students. *Gifted Child Quarterly*, 28, 115-119.
- Hanna, G., & Mason, J. (2014). Key ideas and memorability in proof. *For the Learning of Mathematics*, 34, 12-16.
- Hanna, G., & Villiers, M. D. (2008). ICMI Study 19: Proof and proving in Mathematics education. *ZDM*, 40(2), 329-336.
- Hui, A. N. N., & Lau, S. (2010). Formulation of policy and strategy in developing creativity education in four Asian Chinese societies: A policy analysis. *Journal of Creative Behavior*, 44, 215-235. Retrieved from <http://dx.doi.org/10.1002/j.2162-6057.2010.tb01334.x>
- Kanevsky, L., & Keighley, T. (2003). To produce or not to produce? Understanding boredom and the honor in underachievement. *Roeper Review*, 26, 20-28. Retrieved from <http://dx.doi.org/10.1080/02783190309554235>
- Krathwohl, D. R. (2002). A revision of Bloom's taxonomy: An overview. *Theory into Practice*, 41(4), 212-218.
- Krathwohl, D. R., Bloom, B. S., & Masia, B. B. (Eds.). (1964). *Taxonomy of educational objectives: The classification of educational goals. Handbook II: Cognitive domain*. New York: David McKay.
- Little, C. A. (2018). Teaching strategies to support the education of gifted learners in Asia. In S. I. Pfeiffer (Ed.), *APA handbook of giftedness and talent* (pp. 371-385). Retrieved from <http://dx.doi.org/10.1037/0000038-024>

- Maker, J. C., & Nielson, A. B. (1996). *Curriculum development and teaching strategies for gifted learners*. Austin, TX: Pro-Ed.
- Marland, S. P., Jr. (1972). *Education of the gifted and talented: Vol. 1. Report to the Congress of the United States by the U.S. Commissioner of Education*. Washington, DC: U.S. Government Printing Office.
- Matthews, D. J., & Foster, J. F. (2009). *Being smart about gifted education: A guidebook for educators and parents* (2nd ed.). Scottsdale, AZ: Great Potential Press.
- Olatoye, R. A., Akitunde, S. O., & Ogunsanya, E. A. (2010). Relationship between creativity and academic achievement of business administration students in South Western Polytechnics, Nigeria. *An International Multi-Disciplinary Journal*, 4(3a), 134-149.
- Peterson, J. S. (2015). School counselors and gifted kids: Respecting both cognitive and affective. *Journal of Counseling and Development*, 93, 153-162.
- Reis, S. M., & Purcell, J. H. (1993). An analysis of content elimination and strategies used by elementary classroom teachers in the curriculum compacting process. *Journal for the Education of the Gifted*, 16, 147-170. Retrieved from <http://dx.doi.org/10.1177/016235329301600205>
- Renzulli, J. S. (1978). What makes giftedness? Re-examining a definition. *Phi Delta Kappan*, 60(3), 180-261.
- Renzulli, J. S. (2003). The schoolwide enrichment model: An overview of the theoretical and organizational rationale. *Gifted Education International*, 18, 4-14.
- Renzulli, J. S. (2010). *The three-ring conception of giftedness: A developmental model for promoting creative productivity*. Retrieved from <https://www.cambridge.org/core/terms>
- Renzulli, J. S., & Reis, S. M. (1994). Research related to the schoolwide enrichment model. *Gifted Child Quarterly*, 38, 2-14.
- Renzulli, J. S., & Reis, S. M. (1997). *The schoolwide enrichment model: A how-to guide for educational excellence*. Mansfield Center, CT: Creative Learning Press.
- Renzulli, J. S., & Reis, S. M. (2014). *The schoolwide enrichment model: A how-to guide for talent development*. Waco, TX: Prufrock Press Inc.
- Renzulli, J. S., & Renzulli, S. R. (2010). The schoolwide enrichment model: A focus on student strengths and interests. *Gifted Education International*, 26, 140-156. Retrieved from <http://dx.doi.org/10.1177/026142941002600303>
- Robinson, W., & Campbell, J. (2010). *Effective teaching in gifted education: Using a whole-school approach*. New York: Routledge.
- Rogers, K. B. (2007). Lessons learned about educating the gifted and talented: A synthesis of the

- research on educational practice. *Gifted Child Quarterly*, 51, 382-396. Retrieved from <http://dx.doi.org/10.1177/0016986207306324>
- Salovey, P., Bedell, B. T., Detweiler, J. B., & Mayer, J. D. (2000). Current directions in emotional intelligence research. In M. Lewis & J. M. Haviland-Jones (Eds.), *Handbook of emotions* (2nd ed., pp. 504-520). New York, NY: Guilford Press.
- Siegel, M., Borasi, R., & Fonzi, J. (1998). Supporting students' mathematical inquiries through reading. *Journal for Research in Mathematics Education*, 29(4), 378-413.
- Silverman, L. K. (1994). Affective curriculum for the gifted. In J. VanTassel-Baska (Ed.), *Comprehensive curriculum for gifted learners* (pp. 325-346). Massachusetts: Allyn and Bacon.
- Sternberg, R. J. (2003). Creative thinking in the classroom. *Scandinavian Journal of Educational Research*, 47(3), 325-338.
- Sternberg, R. J., & O'Hara, L. A. (1999). Creativity and intelligence. In R. J. Sternberg (Ed.), *Handbook of creativity* (pp. 251-272). New York: Cambridge University Press.
- Sternberg, R. J., & Reis, S. M. (Eds.). (2004). *Definitions of giftedness*. Thousand Oaks, CA: Corwin Press.
- Tinzmann, B. M., Jones, B. F., Fennimore, F. T., Bakker, J., Fine, C., & Pierce, J. (1990). *What is the collaborative classroom?* Retrieved from [https://www.researchgate.net/publication/251574844\\_What\\_Is\\_the\\_Collaborative\\_Classroom](https://www.researchgate.net/publication/251574844_What_Is_the_Collaborative_Classroom)
- Tomlinson, C. A. (1994). Gifted learners: The boomerang kids of middle school? *Roeper Review*, 16, 177-182.
- Tomlinson, C. A. (2000). *Differentiation of instruction in the elementary grades*. Retrieved from <http://files.eric.ed.gov/fulltext/ED443572.pdf>
- Tomlinson, C. A. (2001). *How to differentiate instruction in mixed-ability classrooms*. Alexandria, VA: Association for Supervision and Curriculum Development.
- Tomlinson, C. A. (2005). *How to differentiate instruction in mixed-ability classrooms*. Upper Saddle River, NJ: Pearson.
- Tomlinson, C. A. (2019). *What it means to teach gifted learners well?* Retrieved from <https://www.nagc.org/resources-publications/gifted-education-practices/what-it-means-teach-gifted-learners-well>
- VanTassel-Baska, J. (1986). Effective curriculum and instructional models for talented students. *Gifted Child Quarterly*, 30, 164-169.
- VanTassel-Baska, J. (2003). *Curriculum planning and instructional design for gifted learners*. Denver, CO: Love Publishing.
- VanTassel-Baska, J. (2008). *Assessment of gifted students*. Waco, TX: Prufrock Press.

- VanTassel-Baska, J. (2018). Considerations in curriculum for gifted students. In S. I. Pfeiffer (Ed.), *APA handbook of giftedness and talent* (pp. 371-385). Retrieved from <http://dx.doi.org/10.1037/0000038-023>
- VanTassel-Baska, J., & Chandler, K. L. (2013). *Info-booklet: Differentiation for gifted learners in practice*. Hong Kong: Hong Kong Academy for Gifted Education.
- VanTassel-Baska, J., Cross, T. L., & Olenchak, F. R. (Eds.). (2009). *Social-emotional curriculum with gifted and talented students*. Waco, TX: Prufrock Press Inc.
- VanTassel-Baska, J., Feldhusen, J., Wheatley, C., Seeley, K., Silverman, L., & Foster, W. (1988). *Comprehensive curriculum for gifted learners*. Boston: Allyn & Bacon.
- VanTassel-Baska, J., & Stambaugh, T. (2005). Challenges and possibilities for serving gifted learners in the regular classroom. *Theory into Practice, 44*, 211-217.
- VanTassel-Baska, J., & Stambaugh, T. (2006). *Comprehensive curriculum for gifted learners*. Boston, MA: Pearson.
- Wan, S. W. Y. (2016). Differentiated instruction: Hong Kong prospective teachers' teaching efficacy and beliefs. *Teachers and Teaching, 22*(2), 148-176.
- Wilson, L. O. (2019, March 28). *The second principle*. Retrieved from <https://thesecondprinciple.com/teaching-essentials/beyond-bloom-cognitive-taxonomy-revised/>

### 參考文獻

- 郭靜姿 (2000) 。〈談資優學生的特殊適應問題與輔導〉。《資優教育季刊》，75，1-6。
- 郭靜姿 (2013) 。〈如何實施資優學生的區分性教學?〉。《資優教育季刊》，127，1-11。
- 張玉佩 (2001) 。〈以讀書治療來進行資優學生的情意教育〉。《資優教育季刊》，80，20-30。
- 教育局 (2019) 。《資優生情意輔導攻略》。香港：教育局資優教育組。
- 課程發展議會 (2017) 。《數學教育學習領域課程指引 (小一至中六) 》。香港：課程發展議會。

# 鳴謝

## 香港賽馬會慈善信託基金

### 計劃學校

#### 小學\*

仁濟醫院蔡衍濤小學

北角衛理小學

保良局錦泰小學

香海正覺蓮社佛教陳式宏學校

香港路德會增城兆霖學校

荃灣公立何傳耀紀念小學

軒尼詩道官立小學

馬鞍山循道衛理小學

港澳信義會小學

嗇色園主辦可信學校

筲箕灣崇真學校

聖公會牧愛小學

滬江小學

獻主會小學

靈糧堂秀德小學

#### 中學\*

天主教鳴遠中學

皇仁書院

迦密中學

香港中文大學校友會聯會陳震夏中學

嘉諾撒聖心書院

\*(排名依校名筆劃序)



## 編輯委員會

### 跨院校研究團隊

#### 張志強教授

賽馬會「知優致優」計劃召集人兼聯席總研究顧問  
香港中文大學教育學院大學與學校夥伴協作中心主任  
香港中文大學教育學院教育行政與政策學系主任及教授

#### 石丹理教授

賽馬會「知優致優」計劃聯席總研究顧問  
香港理工大學協理副校長（本科生課程）  
香港理工大學應用社會科學系講座教授  
利豐服務領導教育教授

#### 陳麗君博士

賽馬會「知優致優」計劃聯席總研究顧問  
香港中文大學教育學院「資優計劃」榮譽計劃總監

#### 許娜娜博士

賽馬會「知優致優」計劃高級研究顧問  
香港城市大學社會及行為科學系副教授

### 項目經理

#### 張瑞霞博士

### 專業發展及學校支援組

#### 張俊彥先生

#### 李永健先生

#### 朱婉珊女士

#### 吳靈楓女士

#### 鄭崇禧先生

#### 黎嘉文女士

#### 王致衡先生

#### 張允遜先生

#### 劉錦銘先生

#### 李樂嘉女士

# Acknowledgements

## Hong Kong Jockey Club Charities Trust

### Project Schools

#### Primary Schools\*

Hennessy Road Government Primary School

HHCKLA Buddhist Chan Shi Wan Primary School

Ho Shun Primary School (Sponsored by Sik Sik Yuen)

Hong Kong and Macau Lutheran Church Primary School

Ling Liang Church Sau Tak Primary School

Lutheran Tsang Shing Siu Leun School

Ma On Shan Methodist Primary School

North Point Methodist Primary School

Oblate Primary School

Po Leung Kuk Grandmont Primary School

S.K.H. Good Shepherd Primary School

Shanghai Alumni Primary School

Shaukiwan Tsung Tsin School

Tsuen Wan Public Ho Chuen Yiu Memorial Primary School

Yan Chai Hospital Choi Hin To Primary School

#### Secondary Schools\*

Carmel Secondary School

Catholic Ming Yuen Secondary School

CUHKFAA Chan Chun Ha Secondary School

Queen's College

Sacred Heart Canossian College

\*(listed in alphabetical order)

## Editorial board

### Cross-Institutional Research Consortium

**Prof. Alan C. K. CHEUNG**

Convener & Co-Chief Principal Investigator, Project GIFT  
 Director, Centre for University & School Partnership,  
 Faculty of Education, The Chinese University of Hong Kong  
 Chairperson & Professor, Department of Educational Administration and Policy, Faculty of Education, The Chinese University of Hong Kong

**Prof. Daniel T. L. SHEK**

Co-Chief Principal Investigator, Project GIFT  
 Associate Vice President (Undergraduate Programme) and  
 Chair Professor of Applied Social Sciences,  
 The Hong Kong Polytechnic University  
 Li & Fung Professor in Service Leadership Education

**Dr. Lai Kwan CHAN**

Co-Chief Principal Investigator, Project GIFT  
 Honorary Program Director, Program for the Gifted and Talented, Faculty of Education,  
 The Chinese University of Hong Kong

**Dr. Anna N. N. HUI**

Senior Principal Investigator, Project GIFT  
 Associate Professor, Department of Social & Behavioural Sciences, The City University of Hong Kong

### Project Manager

Dr. Ruby S. H. CHEUNG

### Professional Development and School Support Team

Mr. William C. Y. CHEUNG

Mr. Derek W. K. LEE

Ms. Shirley Y. S. CHU

Ms. Pamela L. F. NG

Mr. Mart CHENG

Ms. Kaman K. M. LAI

Mr. C. H. WONG

Mr. Winson W. S. CHEUNG

Mr. Jayden K. M. LAU

Ms. Jessica L. K. LEE

書名 校本資優教育：學與教資源套 (中學數學及綜合科學科)  
編著 香港中文大學賽馬會「知優致優」計劃  
出版 香港中文大學賽馬會「知優致優」計劃  
設計 A. D. Creations  
印刷 金豐製作有限公司  
九龍觀塘偉業街171號偉業工業大廈4樓A室  
出版日期 2020年1月初版

版權所有 不得翻印

©2020香港中文大學賽馬會「知優致優」計劃

ISBN: 978-988-79690-5-1

**School-based Gifted Education: Learning & Teaching Resource Package  
(Secondary Mathematics & Integrated Science)**

Copyright © 2020 by Jockey Club “Giftedness Into Flourishing Talents” Project

All rights reserved. No part of this book may be reproduced or used in any manner, without the prior written consent of the Jockey Club “Giftedness Into Flourishing Talents” Project, except for non-commercial educational purposes.

First edition January 2020

Book design by A. D. Creations  
Printed by Good Harvest Production Co Ltd

ISBN 978-988-79690-5-1

Published by Jockey Club “Giftedness Into Flourishing Talents” Project



非賣品

ISBN 9789887969051



9 789887 969051